

## **Transnet Port Terminals**

an Operating Division **TRANSNET SOC LTD**

[Registration Number 1990/000900/30]

## **REQUEST FOR PROPOSAL (RFP)**

**FOR THE: REFURBISHMENT OF THE GRAIN ELEVATOR SUBSTATIONS AT THE EAST LONDON MULTI PURPOSE TERMINAL FOR TRANSNET SOC LTD (REG NO. 1990/000900/30) OPERATING AS TRANSNET PORT TERMINALS (HEREINAFTER REFERRED AS "TPT") FOR THE DURATION OF 12 MONTHS**

<b>RFP NUMBER</b>	<b>: iCLM EL 725/TPT</b>
<b>ISSUE DATE</b>	<b>: 25 OCTOBER 2024</b>
<b>COMPULSORY BRIEFING</b>	<b>: 07 NOVEMBER 2024</b>
<b>CLOSING DATE</b>	<b>: 06 DECEMBER 2024</b>
<b>CLOSING TIME</b>	<b>: 12h00pm</b>
<b>TENDER VALIDITY PERIOD</b>	<b>: 12 weeks from closing date</b>

## Contents

### Number    Heading

## The Tender

### Part T1: Tendering Procedures

- T1.1        Tender Notice and Invitation to Tender
- T1.2        Tender Data

### Part T2: Returnable Documents

- T2.1        List of Returnable Document
- T2.2        Returnable Schedules

## The Contract

### Part C1: Agreements and Contract Data

- C1.1        Form of Offer and Acceptance Offer
- C1.2        Contract Data (Parts 1 & 2)
- C1.3        Form of Securities

### Part C2: Pricing Data

- C2.1        Pricing Instructions
- C2.2        Bill of Quantities

### Part C3: Scope of Work

- C3.1        Works Information

### Part C4: Site Information

- C4.1        Site Information

## T1.1 TENDER NOTICE AND INVITATION TO TENDER

### SECTION 1: NOTICE TO TENDERERS

#### 1. INVITATION TO TENDER

Responses to this Tender [hereinafter referred to as a **Tender**] are requested from persons, companies, close corporations or enterprises [hereinafter referred to as a Tenderer]. It is estimated that tenderers must have a CIDB contractor grading designation of 7EP or higher class of construction work.

<b>DESCRIPTION</b>	<b>The refurbishment of the grain elevator substations at the East London Multi Purpose Terminal for Transnet SOC Ltd (Reg no. 1990/000900/30) operating as Transnet Port Terminals (hereinafter referred as "TPT") for the duration of 12 months</b>
<b>TENDER DOWNLOADING</b>	<b>This Tender may be downloaded directly from the National Treasury eTender Publication Portal at <a href="http://www.etenders.gov.za">www.etenders.gov.za</a> and the Transnet website at <a href="https://transnetetenders.azurewebsites.net">https://transnetetenders.azurewebsites.net</a> (please use <b>Google Chrome to access Transnet link</b>) <b>FREE OF CHARGE.</b></b>

<b>COMPULSORY TENDER CLARIFICATION MEETING</b>	<p>A Compulsory Tender Clarification Meeting will be conducted at the <b>Port of East London, Combi Boardroom, 1 Hely Hutchison Road, Quigney on the 7<sup>th</sup> of November 2024., at 12:30pm</b> for a period of ± 3 (three) hours. [Tenderers to provide own transportation and accommodation].</p> <p>The Compulsory Tender Clarification Meeting will start punctually and information will not be repeated for the benefit of Tenderers arriving late.</p> <p>Contact person for directions: <b>Nowhi Hloma (Cell: 066 290 0474)</b></p> <p><b>A Site visit to the Grain Elevator Substations will take place after the clarification meeting, tenderers are to note:</b></p> <ul style="list-style-type: none"> <li>• Tenderers are required to wear safety shoes, high visibility vests and hard hats.</li> <li>• Tenderers without the recommended PPE will not be allowed on the site walk.</li> <li>• Tenderers and their employees, visitors, clients and customers entering Transnet Offices, Depots, Workshops and Stores will have to undergo breathalyser testing.</li> <li>• All forms of firearms are prohibited on Transnet properties and premises.</li> <li>• The relevant persons attending the meeting must ensure that their identity documents, passports or drivers' licences are on them for inspection at the access control gates.</li> </ul>
--	---

	<p>Certificate of Attendance in the form set out in the <b>Returnable Schedule T2.2-01a</b> hereto must be completed and submitted with your Tender as proof of attendance is required for a <b>compulsory</b> site meeting and/or tender briefing.</p> <p><b>Tenderers are required to bring this Returnable Schedule T2.2-01a to the Compulsory Tender Clarification Meeting to be signed by the Employer's Representative.</b></p> <p><b>Tenderers failing to attend the compulsory tender briefing will be disqualified.</b></p>
<b>CLOSING DATE</b>	<p><b>12:00pm on (06 December 2024)</b></p> <p>Tenderers must ensure that tenders are uploaded timeously onto the system. <b>If a tender is late, it will not be accepted for consideration.</b></p>

## 2. TENDER SUBMISSION

Transnet has implemented a new electronic tender submission system, the e-Tender Submission Portal, in line with the overall Transnet digitalization strategy where suppliers can view advertised tenders, register their information, log their intent to respond to bids and upload their bid proposals/responses on to the system.

a) The Transnet e-Tender Submission Portal can be accessed as follows:

Log on to the Transnet eTenders management platform website (<https://transnetetenders.azurewebsites.net>);

- Click on "ADVERTISED TENDERS" to view advertised tenders;
- Click on "SIGN IN/REGISTER – for bidder to register their information (must fill in all mandatory information);
- Click on "SIGN IN/REGISTER" - to sign in if already registered;
- Toggle (click to switch) the "Log an Intent" button to submit a bid;
- Submit bid documents by uploading them into the system against each tender selected.
- **Tenderers are required to ensure that electronic bid submissions are done at least a day before the closing date to prevent issues which they may encounter due to their internet speed, bandwidth or the size of the number of uploads they are submitting. Transnet will not be held liable for any challenges experienced by bidders as a result of the technical challenges. Please do not wait for the last hour to submit. A Tenderer can upload 30mb per upload and multiple uploads are permitted.**

- b) Each company must register its profile using its company details and use the corresponding registered profile to log an intent to bid as well as submitting any bid.
- c) Transnet will not accept a bid or will disqualify a bidder who submits a bid in the Transnet e-tender submission through another bidders'/Company's profile. In other words, each bidder must register the intent to bid and submit its bid through its own profile under the same company name that will eventually bid for the tender. No company shall submit a bid on behalf of another company regardless of the company being a subsidiary or holding company.
- d) In case of a Joint Venture, any of the parties/companies to the Joint Venture may use its registered profile to submit a bid on behalf of the Joint Venture.
- e) The tender offers to this tender will be opened as soon as possible after the closing date and time. Transnet shall not, at the opening of tenders, disclose to any other company any confidential details pertaining to the Tender Offers / information received, i.e. pricing, delivery, etc. The names and locations of the Tenderers will be divulged to other Tenderers upon request.
- f) Submissions must not contain documents relating to any Tender other than that shown on the submission.

### **3. CONFIDENTIALITY**

All information related to this RFP is to be treated with strict confidentiality. In this regard Tenderers are required to certify that they have acquainted themselves with the Non-Disclosure Agreement. All information related to a subsequent contract, both during and after completion thereof, will be treated with strict confidence. Should the need however arise to divulge any information gleaned from provision of the Works, which is either directly or indirectly related to Transnet's business, written approval to divulge such information must be obtained from Transnet.

### **4. DISCLAIMERS**

Tenderers are hereby advised that Transnet is not committed to any course of action as a result of its issuance of this Tender and/or its receipt of a tender offer. In particular, please note that Transnet reserves the right to:

- 4.1. Award the business to the highest scoring Tenderer/s unless objective criteria justify the award to another tenderer.
- 4.2. Not necessarily accept the lowest priced tender or an alternative Tender;
- 4.3. Go to the open market if the quoted rates (for award of work) are deemed unreasonable;

- 4.4. Should the Tenderers be awarded business on strength of information furnished by the Tenderer, which after conclusion of the contract is proved to have been incorrect, Transnet reserves the right to terminate the contract;
  - 4.5. Request audited financial statements or other documentation for the purposes of a due diligence exercise;
  - 4.6. Not accept any changes or purported changes by the Tenderer to the tender rates after the closing date;
  - 4.7. Verify any information supplied by a Tenderer by submitting a tender, the Tenderer/s hereby irrevocably grant the necessary consent to the Transnet to do so;
  - 4.8. Conduct the evaluation process in parallel. The evaluation of Tenderers at any given stage must therefore not be interpreted to mean that Tenderers have necessarily passed any previous stage(s);
  - 4.9. Unless otherwise expressly stated, each tender lodged in response to the invitation to tender shall be deemed to be an offer by the Tenderer. The Employer has the right in its sole and unfettered discretion not to accept any offer.
  - 4.10. Not be held liable if tenderers do not provide the correct contact details during the clarification session and do not receive the latest information regarding this RFP with the possible consequence of being disadvantaged or disqualified as a result thereof.
  - 4.11. Transnet reserves the right to exclude any Tenderers from the tender process who has been convicted of a serious breach of law during the preceding 5 [five] years including but not limited to breaches of the Competition Act 89 of 1998, as amended. Tenderers are required to indicate in tender returnable on T2.2-18, [**Breach of Law**] whether or not they have been found guilty of a serious breach of law during the past 5 [five] years.
  - 4.12. Transnet reserves the right to perform a risk analysis on the preferred tenderer to ascertain if any of the following might present an unacceptable commercial risk to the employer:
    - *unduly high or unduly low tendered rates or amounts in the tender offer;*
    - *contract data of contract provided by the tenderer; or*
    - *the contents of the tender returnables which are to be included in the contract.*
5. Transnet will not reimburse any Tenderer for any preparatory costs or other work performed in connection with this Tender, whether or not the Tenderer is awarded a contract.

## 6. NATIONAL TREASURY'S CENTRAL SUPPLIER DATABASE

Tenderer are required to self-register on National Treasury's Central Supplier Database (CSD) which has been established to centrally administer supplier information for all organs of state and facilitate the verification of certain key supplier information. The CSD can be accessed at <https://secure.csd.gov.za/>. Tenderer are required to provide the following to Transnet in order to enable it to verify information on the CSD:

Supplier Number..... and Unique registration reference number.....(**Tender Data**)

**Transnet urges its clients, suppliers and the general public  
to report any fraud or corruption to  
TIP-OFFS ANONYMOUS: 0800 003 056 OR [Transnet@tip-offs.com](mailto:Transnet@tip-offs.com)**

## T1.2 TENDER DATA

The conditions of tender are the Standard Conditions of Tender as contained in Annex C of the CIDB Standard for Uniformity in Engineering and Construction Works Contracts. The Standard for Uniformity in Construction Procurement was first published in Board Notice 62 of 2004 in Government Gazette No 26427 of 9 June 2004. It was subsequently amended in Board Notice 67 of 2005 in Government Gazette No 28127 of 14 October 2005, Board Notice 93 of 2006 in Government Gazette No 29138 of 18 August 2006, Board Notice No 9 of 2008 in Government Gazette No 31823 of 30 January 2009, Board Notice 86 of 2010 in Government Gazette No 33239 of 28 May 2010, Board Notice 136 of 2015 in Government Gazette 38960 of 10 July 2015 and Board Notice 423 of 2019 in Government Gazette No 42622 of 8 August 2019.

This edition incorporates the amendments made in Board Notice 423 of 2019 in Government Gazette 42622 of 8 August 2019. (see [www.cidb.org.za](http://www.cidb.org.za)).

The Standard Conditions of Tender make several references to Tender data for detail that apply specifically to this tender. The Tender Data shall have precedence in the interpretation of any ambiguity or inconsistency between it and the Standard Conditions of Tender.

Each item of data given below is cross-referenced in the left-hand column to the clause in the Standard Conditions of Tender to which it mainly applies.

Clause	Data
C.1.1	The <i>Employer</i> is <b>Transnet SOC Ltd (Reg No. 1990/000900/30)</b>
C.1.2	The tender documents issued by the <i>Employer</i> comprise:  <b>Part T: The Tender</b>  Part T1: Tendering procedures Part T2 : Returnable documents  <b>Part C: The contract</b>  Part C1: Agreements and contract data Part C2: Pricing data Part C3: Scope of work
	T1.1 Tender notice and invitation to tender T1.2 Tender data  T2.1 List of returnable documents T2.2 Returnable schedules  C1.1 Form of offer and acceptance C1.2 Contract data (Part 1 & 2) C1.3 Form of Securities  C2.1 Pricing instructions C2.2 Bill of Quantities  C3.1 Works Information

Part C4: Site information		C4.1 Site information
C.1.4	The Employer's agent is:	Commodity Specialist
	Name:	Granville van der Merwe
	Address:	TPT Admin Building, Neptune Road, Port of Ngqura
	Tel No.	041 – 507 8501
	E – mail	granville.vandermerwe@transnet.net

### Evaluation Methodology

Transnet will utilise the following methodology and criteria in selecting a preferred Supplier, if so required:

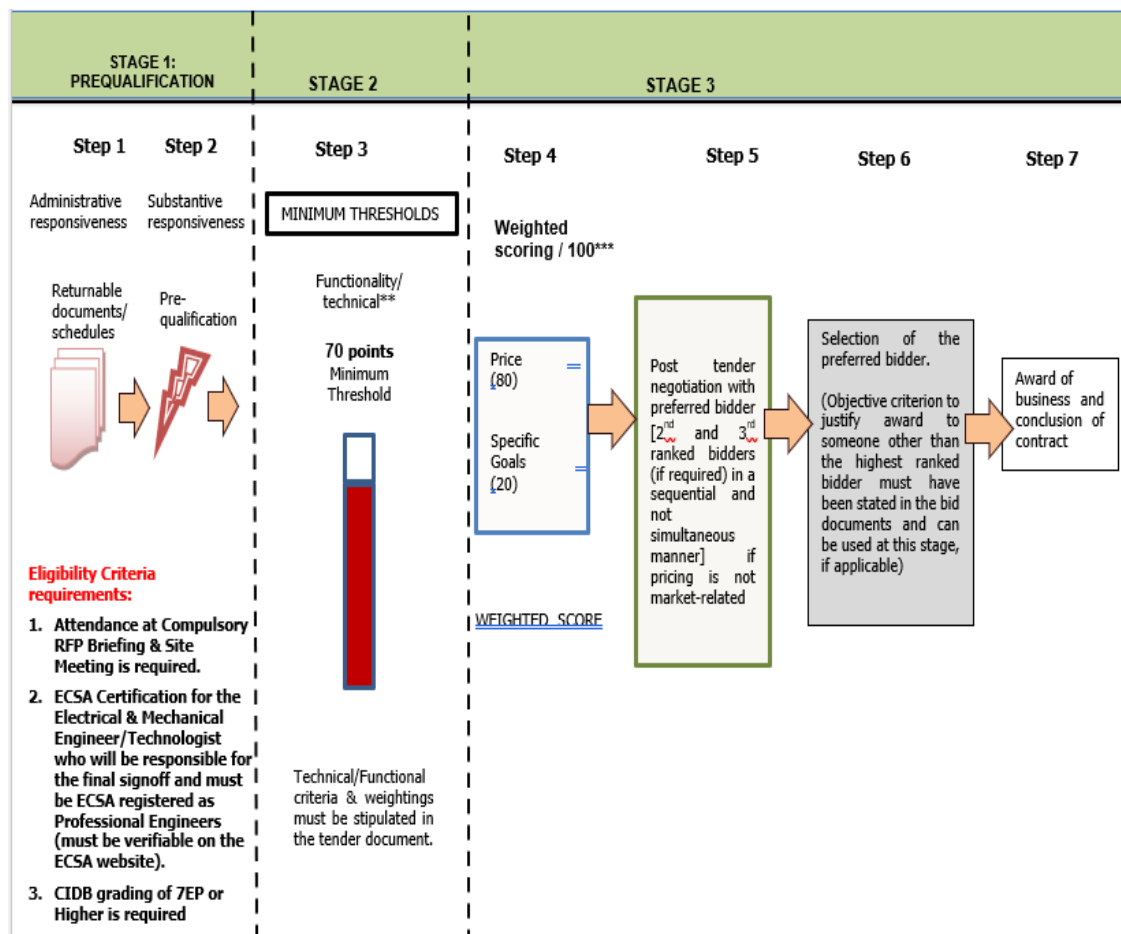

C.2.1 Only those tenderers who satisfy the following eligibility criteria are eligible to submit tenders:

**1. Stage One**

- **Eligibility with regards to attendance at the compulsory clarification meeting:**

An authorised representative of the tendering entity or a representative of a tendering entity that intends to form a Joint Venture (JV) must attend the compulsory clarification meeting in terms C2.7

- **Eligibility with regards to ECSA Certification:**

ECSA Certification is required for the Electrical & Mechanical Engineer/Technologist who will be responsible for the final signoff and must be ECSA registered as Professional Engineers (must be verifiable on the ECSA website).

- **Eligibility in terms of the Construction Industry Development Board:**

a) Only those tenderers who are registered with the CIDB, or are capable of being so prior to the evaluation of submissions, in a contractor grading designation equal to or higher than a contractor grading designation determined in accordance with the sum tendered or a value determined in accordance with Regulation 25 (1B) or 25(7A) of the Construction Industry Development Regulations, designation of **7EP or higher** class of construction work, are eligible to have their tenders evaluated.

b) Joint Venture (JV)

Joint ventures are eligible to submit tenders subject to the following:

1. every member of the joint venture is registered with the CIDB;
2. the lead partner has a contractor grading designation of not lower than one level below the required class of construction works under consideration and possesses the required recognition status; and
3. the combined Contractor grading designation calculated in accordance with the Construction Industry Development Regulations is equal to or higher than a Contractor grading designation determined in accordance with the sum tendered for a 7EP or higher class of construction work or a value determined in accordance with Regulation 25(1B) or 25(7A) of the Construction Industry Development Regulations

The tenderer shall provide a certified copy of its signed joint venture agreement

***Any tenderer that fails to meet the stipulated eligibility criteria will be regarded as an unacceptable tender.***

**2. Stage Two - Functionality:**

Only those tenderers who obtain the minimum qualifying score for functionality will be evaluated further in terms of price and the applicable preference point system. The minimum qualifying for score for functionality is 70 points.

The evaluation criteria for measuring functionality and the points for each criteria and, if any, each sub-criterion are as stated in C.3.11.3 below.

***Any tenderer that fails to meet the stipulated pre-qualifying criteria will be regarded as an unacceptable tender.***

**3. Stage Three – Weighted Scoring (Price & Specific Goals):**

Only tenders that achieve the minimum qualifying score for functionality will be evaluated further in accordance with the 80/20 preference points systems as described in Preferential Procurement Regulations.

**Preferential Procurement points will be allocated as per the table below:**

**Preference Point System 80/20**

<b>Specific Goals</b>	<b>Number of Points</b>	<b>Price</b>
B-BBEE Level 1&2	10	
BO EMEs & QSE (51% BO)	10	
<b>Total</b>	<b>20</b>	<b>80</b>

**Note:** Stage three also includes post tender negotiations, objective criteria and award of business

C.2.7 The arrangements for a compulsory clarification meeting are as stated in the Tender Notice and Invitation to Tender. **Tenderers must complete and sign the attendance register.** Addenda will be issued to and tenders will only be received from those tendering entities including those entities that intends forming a joint venture appearing on the attendance register.

Tenderers are also **required to bring their RFP document to the briefing session and have their returnable document T2.2-01a certificate of attendance** signed off by the Employer’s authorised representative.

C.2.12 No alternative tender offers will be considered.

C.2.13.3 Each tender offer shall be in the **English Language**.

C.2.13.5 The *Employer's* details and identification details that are to be shown on each tender offer are as follows:  
 C2.15.1

Identification details:

The tender documents must be uploaded with:

- Name of Tenderer: **(insert company name)**
- Contact person and details: **(insert details)**
- The Tender Number: iCLM EL 725/TPT
- The Tender Description: The refurbishment of the grain elevator substations at the East London Multi-Purpose Terminal for Transnet SOC Ltd (Reg no. 1990/000900/30) operating as Transnet Port Terminals (hereinafter referred as "TPT") for the duration of 12 months

Documents must be marked for the attention of:

***Employer's Agent: Granville van der Merwe***

C.2.13.9 Telephonic, telegraphic, facsimile or e-mailed tender offers will not be accepted.

C.2.15 The closing time for submission of tender offers is:

Time: **12:00pm** on the **06 December 2024**

Location: The Transnet e-Tender Submission Portal:

(<https://transnetetenders.azurewebsites.net>);

**NO LATE TENDERS WILL BE ACCEPTED**

C.2.16 The tender offer validity period is **12 weeks** after the closing date. Tenderers are to note that they may be requested to extend the validity period of their tender, on the same terms and conditions, if Transnet's internal evaluation and governance approval processes has not been finalised within the validity period.

C.2.23 The tenderer is required to submit with his tender:

1. A valid Tax Clearance Certificate issued by the South African Revenue Services.  
**Tenderers also to provide Transnet with a TCS PIN to verify Tenderers compliance status.**
2. A **valid B-BBEE Certificate** from a Verification Agency accredited by the South African Accreditation System [**SANAS**], or a **sworn affidavit** confirming annual turnover and level of black ownership in case of all EMEs and QSEs with 51% black ownership or more together with the tender;
3. Proof of CIDB in the correct designated grading;
4. Proof of registration on the Central Supplier Database;
5. Letter of Good Standing with the Workmen's compensation fund by the tendering entity or separate Letters of Good Standing from all members of a newly constituted JV.

**Note:** Refer to Section T2.1 for List of Returnable Documents

C3.11 The minimum number of evaluation points for functionality is: **70**

The procedure for the evaluation of responsive tenders is Functionality, Price and Preference:

**Only those tenderers who attain the minimum number of evaluation points for Functionality will be eligible for further evaluation, failure to meet the minimum threshold will result in the tender being disqualified and removed from any further consideration.**

### Functionality Criteria

The functionality criteria and maximum score in respect of each of the criteria are as follows:

Functionality criteria	Sub-criteria	Sub-criteria points	Maximum number of points
<b>T2.2-02 Project Schedule</b>	The Tenderer details the programme for evaluation and attaches it to this schedule. In addition, the Tenderer is to provide an electronic copy of the programme in Primavera or MS project format. The Tenderer's attention is drawn to core clause 31 of the NEC3 Engineering and Construction Contract regarding the items to be shown on a programme.		<b>10</b>
	<p><b>Meet the required timeframes:</b>  Ability to provide the services in terms of the Employer's requirements within the required timeframe as stated in the Works Information and Tender Data by indicating, in a logical sequence, the order, the timing, and the duration of the works that will take place in order to Provide the Works.</p> <p><b>Score 0:</b> The tenderer has submitted no information or inadequate information to determine a score.  <b>Score 20:</b> The programme does not meet any of the required timeframes, key dates and sectional completion dates  <b>Score 40:</b> The programme does not meet all (less than 40%) of the required timeframes, key dates and sectional completion dates  <b>Score 60:</b> The programme does not meet all (more than 40%, but less than or equal</p>	<b>8</b>	

	<p>to 60%) of the required timeframes, key dates and sectional completion dates</p> <p><b>Score 80:</b> The programme does meet all (more than 60%, but less than or equal to 99%) of the required timeframes, key dates and sectional completion dates</p> <p><b>Score 100:</b> The programme does meet All of the required timeframes, key dates and sectional completion dates</p>		
	<p><b>Programme Information:</b></p> <p>The Contractor clearly indicates in the schedule all milestones, activities &amp; information related to the following: Float, Time Risk Allowances, Health and safety requirements, Procedures set out in this contract, Work by the Employer and Others, Access to a part of the site if later than its access date, Acceptances, Plant &amp; Materials and other things to be provided by the employer, Information by Others, Starting date, access dates, Key Dates and Completion Date, Planned Completion for each Key Date for each option and the complete works, how each activity on the Activity Schedule relates to the operations on each programme.</p> <p><b>Score 0:</b> The tenderer has submitted no information or inadequate information to determine a score.</p> <p><b>Score 20:</b> The tenderer has addressed some but not all data requirements as listed in this returnable <b>(4 or less of 12 addressed)</b></p> <p><b>Score 40:</b> The tenderer has addressed some but not all data requirements as listed in this returnable <b>(5 to 6 of 12 addressed)</b></p> <p><b>Score 60:</b> The tenderer has addressed most but not all data requirements as listed in this returnable <b>(7 to 8 of 12 addressed)</b></p> <p><b>Score 80:</b> The tenderer has addressed most but not all data requirements as listed in this returnable <b>(9 to 10 of 12 addressed)</b></p> <p><b>Score 100:</b> The tenderer has addressed all data requirements as listed in this returnable <b>(11 to 12 of 12 addressed)</b></p>	<p><b>2</b></p>	

<b>T2.2-03 Quality Management</b>	The tenderers must sufficiently demonstrate the approach/methodology that will be employed to cover the scope of the project	<b>10</b>
	Project Specific Quality Management Plan for the contract specifically produced for this scope of works as per STD-QAL-0001 project specification. <b>Score 0%:</b> No PQP submitted. <b>Score 20%:</b> PQP does not meet ISO 10005:2018 requirements nor covers the project scope <b>Score 40%:</b> PQP covers the project scope and partially meets ISO 10005:2018 Project Quality Plan requirements <b>Score 60%:</b> PQP meets ISO 10005:2018 requirements and covers the project scope <b>Score 80%:</b> PQP is fully meets ISO 10005:2018 Project Quality Plan requirements. <b>Score 100%:</b> PQP fully meets ISO 10005:2018 Project Quality Plan requirements and makes references all relevant QMS specifications and standards.	<b>2</b>
	Project Specific Quality Data Book Index. <b>Score 0%:</b> No Quality Data book index submitted <b>Score 20%:</b> Quality Data book index is does not cover project scope <b>Score 40%:</b> Quality Data book index is project specific but inadequate to cover project scope. Only one (1) discipline covered <b>Score 60%:</b> Data book index shows adequate understanding of project quality requirements. Only two (2) disciplines covered <b>Score 80%:</b> Data book index shows above average understanding of the project quality requirements. All disciplines covered. <b>Score 100%:</b> The Data book index covers all disciplines including all relevant tests and certifications to be provided.	<b>2</b>
	Procedures and Method statements to be used. <b>Score 0%:</b> No list of QMS procedures and method statement (MS) submitted	<b>2</b>

	<p><b>Score 20%:</b> Index / list of QMS procedures and method statement is not project specific as per ISO 9001:2015/O.E.M. certification or equivalent</p> <p><b>Score 40%:</b> Index / list of QMS procedures and method statements is inadequate to cover project scope as per ISO 9001:2015/O.E.M. certification or equivalent. MS list covers Only one (1) discipline.</p> <p><b>Score 60%:</b> Index / list of QMS procedures and method statements partially covers project scope requirements as per ISO 9001:2015/O.E.M. certification or equivalent. MS list covers Only two (2) disciplines</p> <p><b>Score 80%:</b> Index / list of QMS procedures and method statements fully covers all project scope requirements as per ISO 9001:2015/O.E.M. certification or equivalent. MS list covers all disciplines</p> <p><b>Score 100%:</b> Index / list of procedures and method statements covers all project scope requirements as per ISO 9001:2015/O.E.M. certification or equivalent. MS list covers all disciplines as well as list relevant check sheets / forms.</p>		
	<p>Order and timing of the audits, inspection and design milestones that will take place in order to provide the works.</p> <p><b>Score 0%:</b> No audit schedule submitted</p> <p><b>Score 20%:</b> Audit Schedule does not cover quality audit requirements of the project scope.</p> <p><b>Score 40%:</b> The Audit Schedule is inadequate to cover most of the quality audit (Not all disciplines and covered).</p> <p><b>Score 60%:</b> The Audit Schedule has adequate audits to cover most audit quality requirements for the project scope.</p> <p><b>Score 80%:</b> The Audit Schedule covers all the required audit requirements for the project scope. All clauses of ISO 9001 are covered. All disciplines covered</p> <p><b>Score 100%:</b> The Audit Schedule exceeds the required quality audit requirements of the scope. All clauses of ISO 9001 are covered. All disciplines covered</p>	<p><b>2</b></p>	

	<p>Project specific Quality Control Plan (QCP).  <b>Score 0%:</b> No QCPs submitted  <b>Score 20%:</b> QCPs do not cover project scope.  <b>Score 40%:</b> QCPs are project specific but inadequate to cover project scope. Only one (1) discipline covered  <b>Score 60%:</b> QCP's shows adequate understanding of project quality requirements. Only two (2) disciplines covered  <b>Score 80%:</b> QCP's shows above average understanding of the project quality requirements, All disciplines covered.  <b>Score 100%:</b> QCP's covers all disciplines and intervention points with reference to standards, specifications, drawings, etc.</p>	<b>2</b>	
<b>T2.2-04 Previous Experience</b>	<p>Tenderers are required to demonstrate their past experience in the delivery of similar projects "of a minimum value of R8m per project" areas, conditions and circumstances in relation to the scope of work in the last 10 years, and to this end shall supply a sufficiently detailed reference list with contact details for tracing and verification of customers, indicate previous experience, and provide completion certificates. Tenderers are required to provide sufficient information about the reference work previously undertaken because only references that are similar to the scope of work of this contract will be considered for evaluation.</p>		<b>25</b>
	<p>Electrical MV 70% and LV 30% infrastructure works.  <b>Score 0%:</b> The tenderer has submitted no information or inadequate information to determine a score.  <b>Score 20%:</b> The tenderer has sufficient experience in relation to the project and has worked previously under similar conditions and circumstances and has successfully completed more than 1 similar projects.  <b>Score 40%:</b> The tenderer has sufficient experience in relation to the project and has worked previously under similar conditions and circumstances and has successfully completed more than 2 similar projects.  <b>Score 60%:</b> The tenderer has sufficient experience in relation to the project and has worked previously under similar conditions</p>	<b>12</b>	

	<p>and circumstances and has successfully completed more than 3 similar projects. <b>Score 80%:</b> The tenderer has sufficient experience in relation to the project and has worked previously under similar conditions and circumstances and has successfully completed more than 4 similar projects. <b>Score 100%:</b> The tenderer has sufficient experience in relation to the project and has worked previously under similar conditions and circumstances and has successfully completed more than 5 similar projects.</p>		
	<p>Earthing and lightning protection 30%, and power systems modelling and simulation 70% <b>Score 0%:</b> The tenderer has submitted no information or inadequate information to determine a score. <b>Score 20%:</b> The tenderer has sufficient experience in relation to the project and has worked previously under similar conditions and circumstances and has successfully completed more than 1 similar projects. <b>Score 40%:</b> The tenderer has sufficient experience in relation to the project and has worked previously under similar conditions and circumstances and has successfully completed more than 2 similar projects. <b>Score 60%:</b> The tenderer has sufficient experience in relation to the project and has worked previously under similar conditions and circumstances and has successfully completed more than 3 similar projects. <b>Score 80%:</b> The tenderer has sufficient experience in relation to the project and has worked previously under similar conditions and circumstances and has successfully completed more than 4 similar projects. <b>Score 100%:</b> The tenderer has sufficient experience in relation to the project and has worked previously under similar conditions and circumstances and has successfully completed more than 5 similar projects.</p>	<b>8</b>	
	<p>Automatic fire smoke detection and suppression system 50%, HVAC 50% <b>Score 0%:</b> The tenderer has submitted no information or inadequate information to determine a score.</p>	<b>5</b>	

	<p><b>Score 20%:</b> The tenderer has sufficient experience in relation to the project and has worked previously under similar conditions and circumstances and has successfully completed more than 1 similar projects.</p> <p><b>Score 40%:</b> The tenderer has sufficient experience in relation to the project and has worked previously under similar conditions and circumstances and has successfully completed more than 2 similar projects.</p> <p><b>Score 60%:</b> The tenderer has sufficient experience in relation to the project and has worked previously under similar conditions and circumstances and has successfully completed more than 3 similar projects.</p> <p><b>Score 80%:</b> The tenderer has sufficient experience in relation to the project and has worked previously under similar conditions and circumstances and has successfully completed more than 4 similar projects.</p> <p><b>Score 100%:</b> The tenderer has sufficient experience in relation to the project and has worked previously under similar conditions and circumstances and has successfully completed more than 5 similar projects.</p>		
<b>T.2.2.05 Method Statement</b>	<p>The Tenderer must submit a method statement which responds to the scope of work and outlines construction methodology including the relating but not limited to the programme, quality, health, safety, risk, environment, and an understanding of the project objectives.</p> <p><b>Electrical MV and LV infrastructure Installation Works (60%)</b>  <b>Power system modelling and simulation (20%)</b>  <b>Installation of automatic fire/smoke detection and suppression system, and HVAC (20%)</b></p> <p>Clearly articulated and based on the Works Information which includes the design, general arrangements of switchgear, power system study investigations and criteria. Approach to ensuring less disruption to operations.</p> <p><b>Score 0%:</b> The tenderer has submitted no information or inadequate information to determine a score</p>	<b>8</b>	<b>20</b>

	<p><b>Score 20%:</b> The approach paper is not acceptable as it will not satisfy project objectives or requirements. The tenderer has misunderstood the scope of work and does not deal with the critical aspects of the project.</p> <p><b>Score 40%:</b> The technical approach and / or methodology is poor, not realistic, and practical and is therefore unlikely to satisfy project objectives or requirements. The tenderer has misunderstood certain aspects of the scope of work and does not deal with the critical aspects of the project.</p> <p><b>Score 60%:</b> The approach is generic and not tailored to address the specific project objectives and requirements. The approach does not adequately deal with the critical characteristics of the project. The approach to managing risk is too generic.</p> <p><b>Score 80%:</b> The approach is specifically tailored to address the specific project objectives and methodology and is sufficiently flexible to accommodate changes that may occur during execution. The approach to managing risk etc. is specifically tailored to the critical characteristics of the project.</p> <p><b>Score 100%:</b> Besides meeting the "80" rating, the important issues are approached in an innovative and efficient way, indicating that the tenderer has outstanding knowledge of state-of-the- art approaches. The approach paper details ways to improve the project outcomes and the quality of the outputs.</p>		
	<p>Demonstrates a clear understanding of the project objectives and the employer's specifications. Clear construction, and commissioning methodology. Outline the project specific requirements of the SHEQ requirements.</p> <p><b>Score 0%:</b> The tenderer has submitted no information or inadequate information to determine a score</p> <p><b>Score 20%:</b> The method statement is not acceptable as it will not satisfy project objectives or requirements. The tenderer has</p>	<p><b>12</b></p>	

	<p>misunderstood the scope of work and does not deal with any aspects of the project.</p> <p><b>Score 40%:</b> The approach is generic and not tailored to address the specific project objectives and requirements. The approach does not adequately deal with the critical characteristics of the project. The approach to managing risk is too generic.</p> <p><b>Score 60%:</b> Satisfactory response/solution to the particular aspect of the requirement and evidence given that the stated employer's requirements will be met. Just complies with the employer's scope.</p> <p><b>Score 80%:</b> The approach is specifically tailored to address the specific project objectives and methodology and is sufficiently flexible to accommodate changes that may occur during execution. The approach to managing risk etc is specifically tailored to the critical characteristics of the project. Complies with the employer's scope.</p> <p><b>Score 100%:</b> Besides meeting the "80" rating, the important issues are approached in an innovative and efficient way, indicating that the tenderer has outstanding knowledge of state-of-the-art approaches. The method statement details ways to improve the project outcomes and the quality of the outputs. Above the employer's scope requirements.</p>		
<p style="writing-mode: vertical-rl; transform: rotate(180deg);"><b>T.2.2-06 Management and CV's of Key Personnel</b></p>	<p>The Tenderer must be able to demonstrate that the project personnel have sufficient knowledge, experience and qualifications to provide the required services</p>		<p><b>25</b></p>
	<p><b>Relevant Technical experience:</b>  <b>Management and Engineering= 100%</b>  10% Project Manager  30% Contract Manager  20% Protection Specialist  20% Mechanical Engineer  20% Installation Electrician</p> <p><b>Score 0%:</b> Failed to provide information or inadequate information provided to determine a score</p> <p><b>Score 20%:</b> Key staff do not have relevant levels of relevant experience.  Project Manager: ≥1 &lt; 3 years  Construction Manager: ≥1 &lt; 3 years</p>	<p><b>7</b></p>	

	<p>Protection Specialist: <math>\geq 1 &lt; 3</math> years  Mechanical Engineer: <math>\geq 1 &lt; 3</math> years  Installation Electrician: <math>\geq 1 &lt; 3</math> years  <b>Score 40%:</b> Key staff have limited levels of general experience  Project Manager: <math>\geq 3 &lt; 5</math> years  Construction Manager: <math>\geq 3 &lt; 5</math> years  Protection Specialist: <math>\geq 3 &lt; 5</math> years  Mechanical Engineer: <math>\geq 3 &lt; 5</math> years  Installation Electrician: <math>\geq 5 &lt; 10</math> years  <b>Score 60%:</b> Key staff have reasonable levels of general experience  Project Manager: <math>\geq 5 &lt; 8</math> years  Construction Manager: <math>\geq 5 &lt; 8</math> years  Protection Specialist: <math>\geq 5 &lt; 8</math> years  Mechanical Engineer: <math>\geq 5 &lt; 8</math> years  Installation Electrician: <math>\geq 10 &lt; 12</math> years  <b>Score 80%:</b> Key staff have extensive levels of general experience  Project Manager: <math>\geq 8 &lt; 12</math> years  Construction Manager: <math>\geq 8 &lt; 12</math> years  Protection Specialist: <math>\geq 8 &lt; 12</math> years  Mechanical Engineer: <math>\geq 8 &lt; 12</math> years  Installation Electrician: <math>\geq 12 &lt; 15</math> years  <b>Score 100%:</b> Key staff have outstanding levels of general experience  Project Manager: <math>\geq 12</math> years  Construction Manager: <math>\geq 12</math> years  Protection Specialist: <math>\geq 12</math> years  Mechanical Engineer: <math>\geq 12</math> years  Installation Electrician: <math>\geq 15</math> years</p>		
	<p><b>Education, training and skills for the following:</b>  <b>Management and Engineering =100%</b>  10% Project Manager  30% Contract Manager  20% Protection Specialist  20% Mechanical Engineer  20% Installation Electrician  <b>Score 0%:</b> Failed to provide information or inadequate information provided to determine a score  <b>Score 20%:</b> Key staff does not have project specific education, skills, training and experience as indicated above.  Project Manager: <math>\geq 1 &lt; 3</math> years  Construction Manager: <math>\geq 1 &lt; 3</math> years</p>	8	

	<p>Protection Specialist: <math>\geq 1 &lt; 3</math> years  Mechanical Engineer: <math>\geq 1 &lt; 3</math> years  Installation Electrician: <math>\geq 1 &lt; 3</math> years  <b>Score 40%:</b> Key staff have limited levels of project specific education, skills, training and experience.  Project Manager: <math>\geq 3 &lt; 5</math> years  Construction Manager: <math>\geq 3 &lt; 5</math> years  Protection Specialist: <math>\geq 3 &lt; 5</math> years  Mechanical Engineer: <math>\geq 3 &lt; 5</math> years  Installation Electrician: <math>\geq 5 &lt; 10</math> years  <b>Score 60%:</b> Key staff have reasonable levels of project specific education, skills, training and experience  Project Manager: <math>\geq 5 &lt; 8</math> years  Construction Manager: <math>\geq 5 &lt; 8</math> years  Protection Specialist: <math>\geq 5 &lt; 8</math> years  Mechanical Engineer: <math>\geq 5 &lt; 8</math> years  Installation Electrician: <math>\geq 10 &lt; 12</math> years  <b>Score 80%:</b> Key staff have extensive levels of project specific education, skills, training and experience  Project Manager: <math>\geq 8 &lt; 12</math> years  Construction Manager: <math>\geq 8 &lt; 12</math> years  Protection Specialist: <math>\geq 8 &lt; 12</math> years  Mechanical Engineer: <math>\geq 8 &lt; 12</math> years  Installation Electrician: <math>\geq 12 &lt; 15</math> years  <b>Score 100%:</b> Key staff have outstanding levels of project specific education, skills, training and experience  Project Manager: <math>\geq 12</math> years  Construction Manager: <math>\geq 12</math> years  Protection Specialist: <math>\geq 12</math> years  Mechanical Engineer: <math>\geq 12</math> years  Installation Electrician: <math>\geq 15</math> years</p>		
	<p><b>Knowledge of issues pertinent to the project for the following:  Management and Engineering = 100%</b>  10% Project Manager  30% Contract Manager  20% Protection Specialist  20% Mechanical Engineer  20% Installation Electrician  <b>Score 0%:</b> Failed to provide information or inadequate information provided to determine a score</p>	<b>10</b>	

	<p><b>Score 20%:</b> Key staff has no experience of issues pertinent to the project. Project Manager: <math>\geq 1 &lt; 3</math> years Construction Manager: <math>\geq 1 &lt; 3</math> years Protection Specialist: <math>\geq 1 &lt; 3</math> years Mechanical Engineer: <math>\geq 1 &lt; 3</math> years Installation Electrician: <math>\geq 1 &lt; 3</math> years</p> <p><b>Score 40%:</b> Key staff have limited experience of issues pertinent to the project Project Manager: <math>\geq 3 &lt; 5</math> years Construction Manager: <math>\geq 3 &lt; 5</math> years Protection Specialist: <math>\geq 3 &lt; 5</math> years Mechanical Engineer: <math>\geq 3 &lt; 5</math> years Installation Electrician: <math>\geq 5 &lt; 10</math> years</p> <p><b>Score 60%:</b> Key staff have reasonable experience of issues pertinent to the project Project Manager: <math>\geq 5 &lt; 8</math> years Construction Manager: <math>\geq 5 &lt; 8</math> years Protection Specialist: <math>\geq 5 &lt; 8</math> years Mechanical Engineer: <math>\geq 5 &lt; 8</math> years Installation Electrician: <math>\geq 10 &lt; 12</math> years</p> <p><b>Score 80%:</b> Key staff have extensive experience of issues pertinent to the project Project Manager: <math>\geq 8 &lt; 12</math> years Construction Manager: <math>\geq 8 &lt; 12</math> years Protection Specialist: <math>\geq 8 &lt; 12</math> years Mechanical Engineer: <math>\geq 8 &lt; 12</math> years Installation Electrician: <math>\geq 12 &lt; 15</math> years</p> <p><b>Score 100%:</b> Key staff have outstanding experience of issues pertinent to the project Project Manager: <math>\geq 12</math> years Construction Manager: <math>\geq 12</math> years Protection Specialist: <math>\geq 12</math> years Mechanical Engineer: <math>\geq 12</math> years Installation Electrician: <math>\geq 15</math> years</p>		
<b>T2.2-07 Health &amp; Safety</b>	Contract specific health and safety plan addressing the requirements of TPT health and safety specification		<b>10</b>
	<p><b>Health and Safety Company Policy:</b> signed by the accounting officer and dated (OHS Act, 16.2 appointee)</p> <p><b>Score 0%:</b> No information submitted for evaluation</p> <p><b>score 20%:</b> 1 of the 5 key policy components are recognized and meet the Employer's requirement.</p>	<b>1</b>	

	<p><b>Score 40%:</b> 2 of the 5 key policy components are recognized and meet the Employer's requirement.</p> <p><b>Score 60%:</b> 3 of the 5 key policy components are recognized and meet the Employer's requirements</p> <p><b>Score 80%:</b> 4 of the five key policy components are recognized and meets the Employer's requirements.</p> <p><b>Score 100%:</b> All 5 key policy components are recognized and meets the Employer's requirements</p>		
	<p><b>Roles &amp; Responsibility:</b>          S16.2 Assistant CEO; CR 8.1 Construction Manager (Competent) and CR 8.5 Safety officer (SACPCMP Registered); Risk Assessor; First Aider (trained level 1)</p> <p><b>Score 0%:</b> No information submitted for evaluation</p> <p><b>Score 20%:</b> Roles and responsibilities do not meet the Occupational health and safety Act as per construction regulations and TPT health and safety specification.</p> <p><b>Score 40%:</b> Roles and responsibilities are unlikely to ensure compliance as per the Works information and not in line with OHS Act and TPT health and safety specification.</p> <p><b>Score 60%:</b> Satisfactory response on roles and responsibilities as per Employer's requirements.</p> <p><b>Score 80%:</b> Roles and responsibilities are likely to ensure compliance as per Works Information, OHS Act and TPT health and safety specification.</p> <p><b>Score 100%:</b> Roles and Responsibilities most likely to ensure compliance as per requirements of OHS Act and TPT Health and Safety Management Specification and CV and proof of professional registration with SACPCMP submitted.</p>	<b>2</b>	
	<p><b>Training matrix:</b>          List of key responsible persons (job categories) for the project and health and safety competencies required per category</p> <p><b>Score 0%:</b> No information submitted for evaluation</p>	<b>1</b>	

	<p><b>Score 20%:</b> Key responsible persons are not included on training matrix as per proposed organogram structure.</p> <p><b>Score 40%:</b> Not all key responsible persons are included in the training matrix. Trainings matrix submitted does not cover all SHE training listed on Health and Safety specification. Training matrix not signed by responsible personnel</p> <p><b>Score 60%:</b> Satisfactory response on the list of job categories and trainings as per proposed project organogram structure. Training matrix covers most of the trainings listed on TPT Health and safety specification.</p> <p><b>Score 80%:</b> Most of key persons listed on the training matrix as per proposed project organogram structure. Trainings specified on the matrix are in line with TPT health and safety specification.</p> <p><b>Score 100%:</b> Training matrix include Management and all employees /personnel in the project. Responsible personnel had signed training matrix.</p>		
	<p><b>Overview of the baseline:</b>          Overview of the tenderer's Risk Assessment methodology, and submission of project specific risk assessments indicating major activities of the project to be undertaken.</p> <p><b>Score 0%:</b> No information submitted for evaluation</p> <p><b>Score 20%:</b> Information supplied is very insignificant/inadequate to achieve the required standard of service.</p> <p><b>Score 40%:</b> Poor response/answer/solution lacks convincing evidence, medium risk that stated Employer's requirements will not be met.</p> <p><b>Score 60%:</b> Satisfactory response/answer/solution to the particular aspect of the requirement, evidence given that the stated Employer's requirements will be met.</p> <p><b>Score 80%:</b> Good response/answer/solution which demonstrates real understanding and evidence of ability to meet stated Employer's requirements.</p>	<p><b>2</b></p>	

	<p><b>Score 100%:</b> Very good response/answer/solution gives real confidence that the tenderer is most likely to ensure compliance with stated Employer's requirements</p>		
	<p><b>Two years synopsis:</b> SHE incidents, description, type and action taken to prevent re-occurrence</p> <p><b>Score 0%:</b> No information submitted for evaluation</p> <p><b>Score 20%:</b> Information supplied is very insignificant/inadequate to achieve the required standard of service.</p> <p><b>Score 40%:</b> Poor response/answer/solution lacks convincing evidence, medium risk that stated Employer's requirements will not be met.</p> <p><b>Score 60%:</b> Satisfactory response/answer/solution to the particular aspect of the requirement, evidence given that the stated Employer's requirements will be met.</p> <p><b>Score 80%:</b> Good response/answer/solution which demonstrates real understanding and evidence of ability to meet stated Employer's requirements.</p> <p><b>Score 100%:</b> Very good response/answer/solution gives real confidence that the tenderer is most likely to ensure compliance with stated Employer's requirements</p>	<p><b>1</b></p>	
	<p><b>Cost Breakdown Sheet:</b> Submission of completed cost breakdown sheet</p> <p><b>Score 0%:</b> No information submitted for evaluation</p> <p><b>Score 20%:</b> Health and safety Budget submitted is very insignificant/inadequate to achieve the required standard of service, 0 to 1% allocated.</p> <p><b>Score 40%:</b> Health and safety Budget submitted is insignificant/inadequate /answer/solution to the returnable, Employer's health and safety requirements will not be met, 1.1 – 2% allocated.</p>	<p><b>1</b></p>	

	<p><b>Score 60%:</b> Health and safety Budget submitted is Satisfactory response/answer/solution to the returnable, Employer's health and safety requirements will be met, 2.1 – 3% allocated</p> <p><b>Score 80%:</b> Health and safety Budget submitted is good response/answer/solution to the returnable, Employer's health and safety requirements will be met, 3% - above allocated.</p> <p><b>Score 100%:</b> Health and safety Budget submitted is Very good response/answer/solution to the returnable, Employer's health and safety requirements will be met, 4% - above allocated.</p>		
	<p><b>Safety Questionnaire:</b>  Complete and return with tender documentation the required supporting documentation included as an Annexure.</p> <p><b>Score 0%:</b> No information submitted for evaluation</p> <p><b>Score 20%:</b> Information supplied is very insignificant/inadequate to achieve the required standard of service.</p> <p><b>Score 40%:</b> Poor response/answer/solution lacks convincing evidence, medium risk that stated Employer's requirements will not be met.</p> <p><b>Score 60%:</b> Satisfactory response/answer/solution to the particular aspect of the requirement, evidence given that the stated Employer's requirements will be met.</p> <p><b>Score 80%:</b> Good response/answer/solution which demonstrates real understanding and evidence of ability to meet stated Employer's requirements.</p> <p><b>Score 100%:</b> Very good response/answer/solution gives real confidence that the tenderer is most likely to ensure compliance with stated Employer's requirements</p>	<p><b>2</b></p>	
<b>Total Weighting</b>			<b>100</b>
<b>Minimum qualifying score required = 70%</b>			

Functionality shall be scored independently by not less than 3 (three) evaluators and averaged in accordance with the following schedules:

- T2.2-02 Project Schedule
- T2.2-03 Quality Management
- T2.2-04 Previous Experience
- T2.2-05 Method Statement
- T2.2-06 Management and CV's of Key Personnel
- T2.2-07 Health & Safety

Each evaluation criteria will be assessed in terms of scores of 0, 20, 40, 60, 80 or 100

The scores of each of the evaluators will be averaged, weighted and then totalled to obtain the final score for functionality, unless scored collectively. (See CIDB Inform Practice Note #9).

**Note: Any tender not complying with the above-mentioned requirements, will be regarded as non-responsive and will therefore not be considered for further evaluation. This note must be read in conjunction with Clause C.2.1.**

---

C.3.11. Only tenders that achieve the minimum qualifying score for functionality will be evaluated further in accordance with the 80/20 preference points systems as described in Preferential Procurement Regulations.

80 where the financial value of one or more responsive tenders received have a value equal to or below R50 million, inclusive of all applicable taxes,

Up to 100 minus  $W_1$  tender evaluation points will be awarded to tenderers who complete the preferencing schedule and who are found to be eligible for the preference claimed. **Should the BBBEE rating not be provided, tenderers with no verification will score zero points for preferencing.**

**Note:** Transnet reserves the right to carry out an independent audit of the tenderers scorecard components at any stage from the date of close of the tenders until completion of the contract.

---

C.3.13 Tender offers will only be accepted if:

1. The tenderer or any of its directors/shareholders is not listed on the Register of Tender Defaulters in terms of the Prevention and Combating of Corrupt Activities Act of 2004 as a person prohibited from doing business with the public sector;
2. the tenderer does not appear on Transnet's list for restricted tenderers and National Treasury's list of Tender Defaulters;
3. the tenderer has fully and properly completed the Compulsory Enterprise Questionnaire and there are no conflicts of interest which may impact on the tenderer's ability to perform the contract in the best interests of the Employer or potentially compromise the tender process and persons in the employ of the state.
4. Transnet reserves the right to award the tender to the tenderer who scores the highest number of points overall, unless there are **objective criteria** which will justify the award of the tender to another tenderer. Objective criteria include but are not limited to the outcome of a due diligence exercise to be conducted. The due diligence exercise may take the following factors into account inter alia;

the tenderer:

- a) is not under restrictions, or has principals who are under restrictions, preventing participating in the employer's procurement,
- b) can, as necessary and in relation to the proposed contract, demonstrate that he or she possesses the professional and technical qualifications, professional and technical competence, financial resources, equipment and other physical facilities, managerial capability, reliability, experience and reputation, expertise and the personnel, to perform the contract,
- c) has the legal capacity to enter into the contract,
- d) is not insolvent, in receivership, under Business Rescue as provided for in chapter 6 of the Companies Act, 2008, bankrupt or being wound up, has his affairs administered by a court or a judicial officer, has suspended his business activities, or is subject to legal proceedings in respect of any of the foregoing,
- e) complies with the legal requirements, if any, stated in the tender data and
- f) is able, in the option of the employer to perform the contract free of conflicts of interest.

---

C.3.17 The number of paper copies of the signed contract to be provided by the Employer is 1 (one).

---

**STAATSKOERANT, 8 AUGUSTUS 2019**

**DEPARTMENT OF PUBLIC WORKS**

**NOTICE 423 OF 2019**

**STANDARD FOR UNIFORMITY IN ENGINEERING AND CONSTRUCTION**

**WORKS CONTRACTS**

**AUGUST 2019**

## **Annex C**

### **Standard Conditions of Tender**

#### **C.1 General**

##### **C.1.1 Actions**

C.1.1.1 The employer and each tenderer submitting a tender offer shall comply with these conditions of tender. In their dealings with each other, they shall discharge their duties and obligations as set out in C.2 and C.3, timeously and with integrity, and behave equitably, honestly and transparently, comply with all legal obligations and not engage in anticompetitive practices.

C.1.1.2 The employer and the tenderer and all their agents and employees involved in the tender Process shall avoid conflicts of interest and where a conflict of interest is perceived or known, declare any such conflict of interest, indicating the nature of such conflict. Tenderers shall declare any potential conflict of interest in their tender submissions. Employees, agents and advisors of the employer shall declare any conflict of interest to whoever is responsible for overseeing the procurement process at the start of any deliberations relating to the procurement process or as soon as they become aware of such conflict and abstain from any decisions where such conflict exists or recuse themselves from the procurement process, as appropriate.

*Note: 1) A conflict of interest may arise due to a conflict of roles which might provide an incentive for improper acts in some circumstances. A conflict of interest can create an appearance of impropriety that can undermine confidence in the ability of that person to act properly in his*

---

*or her position even if no improper acts result.*

2) *Conflicts of interest in respect of those engaged in the procurement process include direct, indirect or family interests in the tender or outcome of the procurement process and any personal bias, inclination, obligation, allegiance or loyalty which would in any way affect any decisions taken.*

C.1.1.3 The employer shall not seek and a tenderer shall not submit a tender without having a firm intention and the capacity to proceed with the contract.

### **C.1.2 Tender Documents**

The documents issued by the employer for the purpose of a tender offer are listed in the tender data.

### **C.1.3 Interpretation**

C.1.3.1 The tender data and additional requirements contained in the tender schedules that are included in the returnable documents are deemed to be part of these conditions of tender.

C.1.3.2 These conditions of tender, the tender data and tender schedules which are required for tender evaluation purposes, shall form part of any contract arising from the invitation to tender.

C.1.3.3 For the purposes of these conditions of tender, the following definitions apply:

a) **conflict of interest** means any situation in which:

- i) someone in a position of trust has competing professional or personal interests which make it difficult to fulfill his or her duties impartially;
- ii) an individual or tenderer is in a position to exploit a professional or official capacity in some way for their personal or corporate benefit; or
- iii) incompatibility or contradictory interests exist between an employee and the tenderer who employs that employee.

b) **comparative offer** means the price after the factors of a non-firm price and all unconditional discounts it can be utilised to have been taken into consideration;

c) **corrupt practice** means the offering, giving, receiving or soliciting of anything of value to influence the action of the employer or his staff or agents in the tender process;

d) **fraudulent practice** means the misrepresentation of the facts in order to influence the tender process or the award of a contract arising from a tender offer to the detriment of the employer, including collusive practices intended to establish prices at artificial levels;

### **C.1.4 Communication and employer's agent**

Each communication between the employer and a tenderer shall be to or from the employer's agent only, and in a form that can be readily read, copied and recorded. Communications shall be in the English language. The employer shall not take any responsibility for non-receipt of communications

---

from or by a tenderer. The name and contact details of the employer's agent are stated in the tender data.

### **C.1.5 Cancellation and Re-Invitation of Tenders**

C.1.5.1 An employer may, prior to the award of the tender, cancel a tender if

- a) due to changed circumstances, there is no longer a need for the engineering and construction works specified in the invitation;
- b) funds are no longer available to cover the total envisaged expenditure; or
- c) no acceptable tenders are received.
- d) there is a material irregularity in the tender process.

C.1.5.2 The decision to cancel a tender invitation must be published in the same manner in which the original tender invitation was advertised

C.1.5.3 An employer may only with the prior approval of the relevant treasury cancel a tender Invitation for the second time.

### **C.1.6 Procurement procedures**

#### **C.1.6.1 General**

Unless otherwise stated in the tender data, a contract will, subject to C.3.13, be concluded with the tenderer who in terms of C.3.11 is the highest ranked or the tenderer scoring the highest number of tender evaluation points, as relevant, based on the tender submissions that are received at the closing time for tenders.

#### **C.1.6.2 Competitive negotiation procedure**

C.1.6.2.1 Where the tender data require that the competitive negotiation procedure is to be followed, tenderers shall submit tender offers in response to the proposed contract in the first round of submissions. Notwithstanding the requirements of C.3.4, the employer shall announce only the names of the tenderers who make a submission. The requirements of C.8 relating to the material deviations or qualifications which affect the competitive position of tenderers shall not apply.

C.1.6.2.2 All responsive tenderers or at least a minimum of not less than three responsive tenderers that are highest ranked in terms of the evaluation criteria stated in the tender data shall be invited to enter into competitive negotiations based on the principle of equal treatment, keeping confidential the proposed solutions and associated information. Notwithstanding the provisions of C.2.17, the employer may request that tenders be clarified, Specified and fine-tuned in order to improve a tenderer's competitive position provided that such clarification, specification, fine-tuning or additional information does not alter any

---

fundamental aspects of the offers or impose substantial new requirements which restrict or distort competition or have a discriminatory effect.

C.1.6.2.3 At the conclusion of each round of negotiations, tenderers shall be invited by the employer to revise their tender offer based on the same evaluation criteria, with or without adjusted weightings. Tenderers shall be advised when they are to submit their best and final offer.

C.1.6.2.4 The contract shall be awarded in accordance with the provisions of C.3.11 and C.3.13 after tenderers have been requested to submit their best and final offer.

### **C.1.6.3 Proposal procedure using the two stage-system**

#### **C.1.6.3.1 Option 1**

Tenderers shall in the first stage submit technical proposals and, if required, cost parameters around which a contract may be negotiated. The employer shall evaluate each responsive submission in terms of the method of evaluation stated in the tender data, and in the second stage negotiate a contract with the tenderer scoring the highest number of evaluation points and award the contract in terms of these conditions of tender.

#### **C.1.6.3.2 Option 2**

C.1.6.3.2.1 Tenderers shall submit in the first stage only technical proposals. The employer shall invite all responsive tenderers to submit tender offers in the second stage, following the issuing of procurement documents.

C.1.6.3.2.2 The employer shall evaluate tenders received during the second stage in terms of the method of evaluation stated in the tender data, and award the contract in terms of these conditions of tender.

### **C.2 Tenderer's obligations**

#### **C.2.1 Eligibility**

C.2.1.1 Submit a tender offer only if the tenderer satisfies the criteria stated in the tender data and the tenderer, or any of his principals, is not under any restriction to do business with employer.

C.2.1.2 Notify the employer of any proposed material change in the capabilities or formation of the tendering entity (or both) or any other criteria which formed part of the qualifying requirements used by the employer as the basis in a prior process to invite the tenderer to submit a tender offer and obtain the employer's written approval to do so prior to the closing time for tenders.

---

### **C.2.2 Cost of tendering**

C.2.2.1 Accept that, unless otherwise stated in the tender data, the employer will not compensate the tenderer for any costs incurred in the preparation and submission of a tender offer, including the costs of any testing necessary to demonstrate that aspects of the offer complies with requirements.

C.2.2.2 The cost of the tender documents charged by the employer shall be limited to the actual cost incurred by the employer for printing the documents. Employers must attempt to make available the tender documents on its website so as not to incur any costs pertaining to the printing of the tender documents.

### **C.2.3 Check documents**

Check the tender documents on receipt for completeness and notify the employer of any discrepancy or omission.

### **C.2.4 Confidentiality and copyright of documents**

Treat as confidential all matters arising in connection with the tender. Use and copy the documents issued by the employer only for the purpose of preparing and submitting a tender offer in response to the invitation.

### **C.2.5 Reference documents**

Obtain, as necessary for submitting a tender offer, copies of the latest versions of standards, specifications, conditions of contract and other publications, which are not attached but which are incorporated into the tender documents by reference.

### **C.2.6 Acknowledge addenda**

Acknowledge receipt of addenda to the tender documents, which the employer may issue, and if necessary apply for an extension to the closing time stated in the tender data, in order to take the addenda into account.

### **C.2.7 Clarification meeting**

Attend, where required, a clarification meeting at which tenderers may familiarize themselves with aspects of the proposed work, services or supply and raise questions. Details of the meeting(s) are stated in the tender data.

### **C.2.8 Seek clarification**

Request clarification of the tender documents, if necessary, by notifying the employer at least five (5) working days before the closing time stated in the tender data.

---

### **C.2.9 Insurance**

Be aware that the extent of insurance to be provided by the employer (if any) might not be for the full cover required in terms of the conditions of contract identified in the contract data. The tenderer is advised to seek qualified advice regarding insurance.

### **C.2.10 Pricing the tender offer**

C.2.10.1 Include in the rates, prices, and the tendered total of the prices (if any) all duties, taxes Except Value Added Tax (VAT), and other levies payable by the successful tenderer, such duties, taxes and levies being those applicable fourteen (14) days before the closing time stated in the tender data.

C.2.10.2 Show VAT payable by the employer separately as an addition to the tendered total of the prices.

C.2.10.3 Provide rates and prices that are fixed for the duration of the contract and not subject to adjustment except as provided for in the conditions of contract identified in the contract data.

C.2.10.4 State the rates and prices in Rand unless instructed otherwise in the tender data. The conditions of contract identified in the contract data may provide for part payment in other currencies.

### **C.2.11 Alterations to documents**

Do not make any alterations or additions to the tender documents, except to comply with instructions issued by the employer, or necessary to correct errors made by the tenderer. All signatories to the tender offer shall initial all such alterations.

### **C.2.12 Alternative tender offers**

C.2.12.1 Unless otherwise stated in the tender data, submit alternative tender offers only if a main tender offer, strictly in accordance with all the requirements of the tender documents, is also submitted as well as a schedule that compares the requirements of the tender documents with the alternative requirements that are proposed.

C.2.12.2 Accept that an alternative tender offer must be based only on the criteria stated in the tender data or criteria otherwise acceptable to the employer.

C.2.12.3 An alternative tender offer must only be considered if the main tender offer is the winning tender.

### **C.2.13 Submitting a tender offer**

C.2.13.1 Submit one tender offer only, either as a single tendering entity or as a member in a joint venture to provide the whole of the works identified in the contract data and described in the scope of works, unless stated otherwise in the tender data.

---

C.2.13.2 Return all returnable documents to the employer after completing them in their entirety, either electronically (if they were issued in electronic format) or by writing legibly in non-erasable ink.

C.2.13.3 Submit the parts of the tender offer communicated on paper as an original plus the number Of copies stated in the tender data, with an English translation of any documentation in a language other than English, and the parts communicated electronically in the same format as they were issued by the employer.

C.2.13.4 Sign the original and all copies of the tender offer where required in terms of the tender data. The employer will hold all authorized signatories liable on behalf of the tenderer. Signatories for tenderers proposing to contract as joint ventures shall state which of the signatories is the lead partner whom the employer shall hold liable for the purpose of the tender offer.

C.2.13.5 Seal the original and each copy of the tender offer as separate packages marking the Packages as "ORIGINAL" and "COPY". Each package shall state on the outside the employer's address and identification details stated in the tender data, as well as the tenderer's name and contact address.

C.2.13.6 Where a two-envelope system is required in terms of the tender data, place and seal the returnable documents listed in the tender data in an envelope marked "financial proposal" and place the remaining returnable documents in an envelope marked "technical proposal". Each envelope shall state on the outside the employer's address and identification details stated in the tender data, as well as the tenderer's name and contact address.

C.2.13.7 Seal the original tender offer and copy packages together in an outer package that states on the outside only the employer's address and identification details as stated in the tender data.

C.2.13.8 Accept that the employer will not assume any responsibility for the misplacement or premature opening of the tender offer if the outer package is not sealed and marked as stated.

C.2.13.9 Accept that tender offers submitted by facsimile or e-mail will be rejected by the employer, unless stated otherwise in the tender data.

#### **C.2.14 Information and data to be completed in all respects**

Accept that tender offers, which do not provide all the data or information requested completely and in the form required, may be regarded by the employer as non-responsive.

#### **C.2.15 Closing time**

C.2.15.1 Ensure that the employer receives the tender offer at the address specified in the tender data not later than the closing time stated in the tender data. Accept that proof of posting shall not be accepted as proof of delivery.

---

C.2.15.2 Accept that, if the employer extends the closing time stated in the tender data for any reason, the requirements of these conditions of tender apply equally to the extended deadline.

### **C.2.16 Tender offer validity**

C.2.16.1 Hold the tender offer(s) valid for acceptance by the employer at any time during the validity period stated in the tender data after the closing time stated in the tender data.

C.2.16.2 If requested by the employer, consider extending the validity period stated in the tender data for an agreed additional period with or without any conditions attached to such extension.

C.2.16.3 Accept that a tender submission that has been submitted to the employer may only be withdrawn or substituted by giving the employer's agent written notice before the closing time for tenders that a tender is to be withdrawn or substituted. If the validity period stated in C.2.16 lapses before the employer evaluating tender, the contractor reserves the right to review the price based on Consumer Price Index (CPI).

C.2.16.4 Where a tender submission is to be substituted, a tenderer must submit a substitute tender in accordance with the requirements of C.2.13 with the packages clearly marked as "SUBSTITUTE".

### **C.2.17 Clarification of tender offer after submission**

Provide clarification of a tender offer in response to a request to do so from the employer during the evaluation of tender offers. This may include providing a breakdown of rates or prices and correction of arithmetical errors by the adjustment of certain rates or item prices (or both). No change in the competitive position of tenderers or substance of the tender offer is sought, offered, or permitted.

***Note:** Sub-clause C.2.17 does not preclude the negotiation of the final terms of the contract with a preferred tenderer following a competitive selection process, should the Employer elect to do so.*

### **C.2.18 Provide other material**

C.2.18.1 Provide, on request by the employer, any other material that has a bearing on the tender offer, the tenderer's commercial position (including notarized joint venture agreements), preferencing arrangements, or samples of materials, considered necessary by the employer for the purpose of a full and fair risk assessment. Should the tenderer not provide the material, or a satisfactory reason as to why it cannot be provided, by the time for submission stated in the employer's request, the employer may regard the tender offer as non-responsive.

---

C.2.18.2 Dispose of samples of materials provided for evaluation by the employer, where required.

### **C.2.19 Inspections, tests and analysis**

Provide access during working hours to premises for inspections, tests and analysis as provided for in the tender data.

### **C.2.20 Submit securities, bonds and policies**

If requested, submit for the employer's acceptance before formation of the contract, all securities, bonds, guarantees, policies and certificates of insurance required in terms of the conditions of contract identified in the contract data.

### **C.2.21 Check final draft**

Check the final draft of the contract provided by the employer within the time available for the employer to issue the contract.

### **C.2.22 Return of other tender documents**

If so instructed by the employer, return all retained tender documents within twenty-eight (28) days after the expiry of the validity period stated in the tender data.

### **C.2.23 Certificates**

Include in the tender submission or provide the employer with any certificates as stated in the tender data.

## **C.3 The employer's undertakings**

### **C.3.1 Respond to requests from the tenderer**

C.3.1.1 Unless otherwise stated in the tender Data, respond to a request for clarification received up to five (5) working days before the tender closing time stated in the Tender Data and notify all tenderers who collected tender documents.

C.3.1.2 Consider any request to make a material change in the capabilities or formation of the Tendering entity (or both) or any other criteria which formed part of the qualifying requirements used to prequalify a tenderer to submit a tender offer in terms of a previous procurement process and deny any such request if as a consequence:

- a) an individual firm, or a joint venture as a whole, or any individual member of the joint venture fails to meet any of the collective or individual qualifying requirements;
- b) the new partners to a joint venture were not prequalified in the first instance, either as

---

individual firms or as another joint venture; or

- c) in the opinion of the Employer, acceptance of the material change would compromise the outcome of the prequalification process.

### **C.3.2 Issue Addenda**

If necessary, issue addenda that may amend or amplify the tender documents to each tenderer during the period from the date that tender documents are available until three (3) working days before the tender closing time stated in the Tender Data. If, as a result a tenderer applies for an extension to the closing time stated in the Tender Data, the Employer may grant such extension and, shall then notify all tenderers who collected tender documents.

### **C.3.3 Return late tender offers**

Return tender offers received after the closing time stated in the Tender Data, unopened, (unless it is necessary to open a tender submission to obtain a forwarding address), to the tenderer concerned.

### **C.3.4 Opening of tender submissions**

C.3.4.1 Unless the two-envelope system is to be followed, open valid tender submissions in the presence of tenderers' agents who choose to attend at the time and place stated in the tender data. Tender submissions for which acceptable reasons for withdrawal have been submitted will not be opened.

C.3.4.2 Announce at the meeting held immediately after the opening of tender submissions, at a venue indicated in the tender data, the name of each tenderer whose tender offer is opened and, where applicable, the total of his prices, number of points claimed for its BBBEE status level and time for completion for the main tender offer only.

C.3.4.3 Make available the record outlined in C.3.4.2 to all interested persons upon request.

### **C.3.5 Two-envelope system**

C.3.5.1 Where stated in the tender data that a two-envelope system is to be followed, open only the technical proposal of valid tenders in the presence of tenderers' agents who choose to attend at the time and place stated in the tender data and announce the name of each tenderer whose technical proposal is opened.

C.3.5.2 Evaluate functionality of the technical proposals offered by tenderers, then advise tenderers who remain in contention for the award of the contract of the time and place when the financial proposals will be opened. Open only the financial proposals of tenderers, who score in the functionality evaluation more than the minimum number of points for functionality stated in the tender data, and announce the score obtained for the technical proposals and

---

the total price and any points claimed on BBEE status level. Return unopened financial proposals to tenderers whose technical proposals failed to achieve the minimum number of points for functionality.

### **C.3.6 Non-disclosure**

Not disclose to tenderers, or to any other person not officially concerned with such processes, information relating to the evaluation and comparison of tender offers, the final evaluation price and recommendations for the award of a contract, until after the award of the contract to the successful tenderer.

### **C.3.7 Grounds for rejection and disqualification**

Determine whether there has been any effort by a tenderer to influence the processing of tender offers and instantly disqualify a tenderer (and his tender offer) if it is established that he engaged in corrupt or fraudulent practices.

### **C.3.8 Test for responsiveness**

C.3.8.1 Determine, after opening and before detailed evaluation, whether each tender offer properly received:

- a) complies with the requirements of these Conditions of Tender,
- b) has been properly and fully completed and signed, and
- c) is responsive to the other requirements of the tender documents.

C.3.8.2 A responsive tender is one that conforms to all the terms, conditions, and specifications of the tender documents without material deviation or qualification. A material deviation or qualification is one which, in the Employer's opinion, would:

- a) detrimentally affect the scope, quality, or performance of the works, services or supply identified in the Scope of Work,
- b) significantly change the Employer's or the tenderer's risks and responsibilities under the contract, or
- c) affect the competitive position of other tenderers presenting responsive tenders, if it were to be rectified. Reject a non-responsive tender offer, and not allow it to be subsequently made responsive by correction or withdrawal of the non-conforming deviation or reservation.

### **C.3.9 Arithmetical errors, omissions and discrepancies**

C.3.9.1 Check responsive tenders for discrepancies between amounts in words and amounts in figures. Where there is a discrepancy between the amounts in figures and the amount in words, the amount in words shall govern.

---

C.3.9.2 Check the highest ranked tender or tenderer with the highest number of tender evaluation points after the evaluation of tender offers in accordance with C.3.11 for:

- a) the gross misplacement of the decimal point in any unit rate;
- b) omissions made in completing the pricing schedule or bills of quantities; or
- c) arithmetic errors in:
  - (i) line item totals resulting from the product of a unit rate and a quantity in bills of quantities or schedules of prices; or
  - (ii) the summation of the prices.

C.3.9.3 Notify the tenderer of all errors or omissions that are identified in the tender offer and either confirm the tender offer as tendered or accept the corrected total of prices.

C.3.9.4 Where the tenderer elects to confirm the tender offer as tendered, correct the errors as follows:

- a) If bills of quantities or pricing schedules apply and there is an error in the line item total resulting from the product of the unit rate and the quantity, the line item total shall govern and the rate shall be corrected. Where there is an obviously gross misplacement of the decimal point in the unit rate, the line item total as quoted shall govern, and the unit rate shall be corrected.
- b) Where there is an error in the total of the prices either as a result of other corrections Required by this checking process or in the tenderer's addition of prices, the total of the prices shall govern and the tenderer will be asked to revise selected item prices (and their rates if bills of quantities apply) to achieve the tendered total of the prices.

### **C.3.10 Clarification of a tender offer**

Obtain clarification from a tenderer on any matter that could give rise to ambiguity in a contract arising from the tender offer.

### **C.3.11 Evaluation of tender offers**

The Standard Conditions of Tender standardize the procurement processes, methods and procedures from the time that tenders are invited to the time that a contract is awarded. They are generic in nature and are made project specific through choices that are made in developing the Tender Data associated with a specific project. Conditions of tender are by definition the document that establishes a tenderer's obligations in submitting a tender and the employer's undertakings in soliciting and evaluating tender offers. Such conditions establish the rules from the time a tender is advertised to the time that a contract is awarded and require employers to conduct the process of offer and acceptance in terms of a set of standard procedures.

---

**The CIDB Standard Conditions of Tender are based on a procurement system that satisfies the following system requirements:**

**Requirement Qualitative interpretation of goal**

**Fair** The process of offer and acceptance is conducted impartially without bias, providing simultaneous and timely access to participating parties to the same information.

**Equitable** Terms and conditions for performing the work do not unfairly prejudice the interests of the parties.

**Transparent** The only grounds for not awarding a contract to a tenderer who satisfies all requirements are restrictions from doing business with the employer, lack of capability or capacity, legal impediments and conflicts of interest.

**Competitive** The system provides for appropriate levels of competition to ensure cost effective and best value outcomes.

**Cost effective** The processes, procedures and methods are standardized with sufficient flexibility to attain best value outcomes in respect of quality, timing and price, and least resources to effectively manage and control procurement processes.

**The activities associated with evaluating tender offers are as follows:**

- a) Open and record tender offers received
- b) Determine whether or not tender offers are complete
- c) Determine whether or not tender offers are responsive
- d) Evaluate tender offers
- e) Determine if there are any grounds for disqualification
- f) Determine acceptability of preferred tenderer
- g) Prepare a tender evaluation report
- h) Confirm the recommendation contained in the tender evaluation report

**C.3.11.1 General**

The employer must appoint an evaluation panel of not less than three persons conversant with the proposed scope of works to evaluate each responsive tender offer using the tender evaluation methods and associated evaluation criteria and weightings that are specified in the tender data.

---

### **C.3.12 Insurance provided by the employer**

If requested by the proposed successful tenderer, submit for the tenderer's information the policies and / or certificates of insurance which the conditions of contract identified in the contract data, require the employer to provide.

### **C.3.13 Acceptance of tender offer**

Accept the tender offer; if in the opinion of the employer, it does not present any risk and only if the tenderer:

- a) is not under restrictions, or has principals who are under restrictions, preventing participating in the employer's procurement;
- b) can, as necessary and in relation to the proposed contract, demonstrate that he or she possesses the professional and technical qualifications, professional and technical competence, financial resources, equipment and other physical facilities, managerial capability, reliability, experience and reputation, expertise and the personnel, to perform the contract;
- c) has the legal capacity to enter into the contract;
- d) is not; insolvent, in receivership, under Business Rescue as provided for in chapter 6 of the Companies Act No. 2008, bankrupt or being wound up, has his/her affairs administered by a court or a judicial officer, has suspended his/her business activities or is subject to legal proceedings in respect of any of the foregoing;
- e) complies with the legal requirements, if any, stated in the tender data; and
- f) is able, in the opinion of the employer, to perform the contract free of conflicts of interest.

### **C.3.14 Prepare contract documents**

C.3.14.1 If necessary, revise documents that shall form part of the contract and that were issued by

The employer as part of the tender documents to take account of:

- a) addenda issued during the tender period,
- b) inclusion of some of the returnable documents and
- c) other revisions agreed between the employer and the successful tenderer.

C.3.14.2 Complete the schedule of deviations attached to the form of offer and acceptance, if any.

---

### **C.3.15 Complete adjudicator's contract**

Unless alternative arrangements have been agreed or otherwise provided for in the contract, arrange for both parties to complete formalities for appointing the selected adjudicator at the same time as the main contract is signed.

### **C.3.16 Registration of the award**

An employer must, within twenty-one (21) working days from the date on which a contractor's offer to perform a construction works contract is accepted in writing by the employer, register and publish the award on the cidb Register of Projects.

### **C.3.17 Provide copies of the contracts**

Provide to the successful tenderer the number of copies stated in the Tender Data of the signed copy of the contract as soon as possible after completion and signing of the form of offer and acceptance.

### **C.3.18 Provide written reasons for actions taken**

Provide upon request written reasons to tenderers for any action that is taken in applying these conditions of tender but withhold information which is not in the public interest to be divulged, which is considered to prejudice the legitimate commercial interests of tenderers or might prejudice fair competition between tenderers.



TRANSNET PORT TERMINALS

TENDER NUMBER: iCLM EL 725/TPT

DESCRIPTION OF THE WORKS: THE REFURBISHMENT OF THE GRAIN ELEVATOR SUBSTATIONS AT THE EAST LONDON MULTI PURPOSE TERMINAL FOR TRANSNET SOC LTD (REG NO. 1990/000900/30) OPERATING AS TRANSNET PORT TERMINALS (HEREINAFTER REFERRED AS "TPT") FOR THE DURATION OF 12 MONTHS

## T2.1 List of Returnable Documents

### 2.1.1 These schedules are required for pre-qualification and eligibility purposes:

- T2.2-01a **Stage One as per CIDB: Eligibility Criteria Schedule** - Certificate of attendance at Compulsory Tender Clarification Meeting
- T2.2-01b **Stage One as per CIDB: Eligibility Criteria Schedule** - ECSA Certification
- T2.2-01c **Stage One as per CIDB: Eligibility Criteria Schedule** - CIDB Registration

### 2.1.2 Stage Two as per CIDB: these schedules will be utilised for evaluation purposes:

- T2.2-02 **Evaluation Schedule:** Project Schedule/Programme
- T2.2-03 **Evaluation Schedule:** Quality Management
- T2.2-04 **Evaluation Schedule:** Previous Experience
- T2.2-05 **Evaluation Schedule:** Method Statement
- T2.2-06 **Evaluation Schedule:** Management and CV's of Key Personnel
- T2.2-07 **Evaluation Schedule:** Health & Safety

### Stage Three (Step 4): these schedules will be utilised for Specific Goals:

Valid proof of Respondent's compliance to Specific Goals evidence (Preference Claim Form) requirements stipulated in SBD6.1. (Refer to T2.2-15)

### 2.1.3 Returnable Schedules:

#### General:

- T2.2-08 Authority to submit tender
- T2.2-09 Record of addenda to tender documents
- T2.2-10 Letter of Good Standing
- T2.2-11 Risk Elements
- T2.2-12 Details of Plant Offered
- T2.2-13 Schedule of proposed Subcontractors
- T2.2-14 Site Establishment requirements

#### Agreement and Commitment by Tenderer:

- T2.2-15 CIDB SFU ANNEX G Compulsory Enterprise Questionnaire
- T2.2-16 Non-Disclosure Agreement
- T2.2-17 RFP Declaration Form
- T2.2-18 RFP – Breach of Law



TRANSNET PORT TERMINALS

TENDER NUMBER: iCLM EL 725/TPT

DESCRIPTION OF THE WORKS: THE REFURBISHMENT OF THE GRAIN ELEVATOR SUBSTATIONS AT THE EAST LONDON MULTI PURPOSE TERMINAL FOR TRANSNET SOC LTD (REG NO. 1990/000900/30) OPERATING AS TRANSNET PORT TERMINALS (HEREINAFTER REFERRED AS "TPT") FOR THE DURATION OF 12 MONTHS

T2.2-19 Certificate of Acquaintance with Tender Document

T2.2-20 Service Provider Integrity Pact

T2.2-21 Supplier Code of Conduct

**Bonds/Guarantees/Financial/Insurance:**

T2.2-22 Insurance provided by the Contractor

T2.2-23 Form of Intent to provide a Performance Guarantee

T2.2-24 Three (3) years audited financial statements

**2.2 C1.1 Form of Offer & Acceptance Offer**

**2.3 C1.2 Contract Data**

**2.4 C1.3 Forms of Securities**

**2.5 C2.1 Pricing Instructions (Bill of Quantities)**

**2.6 C2.2 Bill of Quantities**

## T2.2-01a: Eligibility Criteria Schedule:

### Certificate of Attendance at Tender Clarification Meeting

This is to certify that

.....  
(Company Name)

Represented by: .....  
(Name and Surname)

Was represented at the compulsory tender clarification meeting

Held at:	Port of East London, Combi Boardroom, 1 Hely Hutchison Road, Quigney, East London	
On (date)	07 November 2024	Starting time: 12h30

#### Particulars of person(s) attending the meeting:

Name ..... Signature .....

Capacity .....

#### Attendance of the above company at the meeting was confirmed:

Name ..... Signature .....

**For and on Behalf of the  
Employers Agent.** ..... Date .....



TRANSNET PORT TERMINALS

TENDER NUMBER: iCLM EL 725/TPT

DESCRIPTION OF THE WORKS: THE REFURBISHMENT OF THE GRAIN ELEVATOR SUBSTATIONS AT THE EAST LONDON MULTI PURPOSE TERMINAL FOR TRANSNET SOC LTD (REG NO. 1990/000900/30) OPERATING AS TRANSNET PORT TERMINALS (HEREINAFTER REFERRED AS "TPT") FOR THE DURATION OF 12 MONTHS

## T2.2-01b: Eligibility Criteria Schedule - ECSA Certification

Tenderers are to indicate their compliance in terms of **ECSA Certification** by filling in the table below.

**Attach a copy of the ECSA Certificate as a ECSA registered Professional Engineer.**

Failure to comply with eligibility criteria i.e., a "No" answer or "No" response will lead to disqualification.			
Eligibility Criteria:		Comply (Yes/No)	Evidence Provided (Yes/No)
1.	The Tenderer to provide <b>ECSA Certification</b> for the <b>Electrical Engineer/Technologist</b> who will be responsible for the final signoff and must be ECSA registered as a Professional Engineer (must be verifiable on the ECSA website).		
2.	The Tenderer to provide <b>ECSA Certification</b> for the <b>Mechanical Engineer/Technologist</b> who will be responsible for the final signoff and must be ECSA registered as a Professional Engineers (must be verifiable on the ECSA website).		

Signed \_\_\_\_\_ Date \_\_\_\_\_

Name \_\_\_\_\_ Position \_\_\_\_\_

Tenderer \_\_\_\_\_

## T2.2-01c: Eligibility Criteria Schedule - CIDB Grading Designation

### Note to tenderers:

Tenderers are to indicate their CIDB Grading by filling in the table below. **Attach a copy of the CIDB Grading Designation or evidence of being capable of being so registered.**

CRS Number	Status	Grading	Expiry Date

1. Only those tenderers who are registered with the CIDB, or are capable of being so prior to the evaluation of submissions, in a contractor grading designation equal to or higher than a contractor grading designation determined in accordance with the sum tendered or a value determined in accordance with Regulation 25 (1B) or 25(7A) of the Construction Industry Development Regulations, for a **7EP or Higher** class of construction work, are eligible to have their tenders evaluated.

### 2. Joint Venture (JV)

Joint ventures are eligible to submit tenders subject to the following:

1. every member of the joint venture is registered with the CIDB;
2. the lead partner has a contractor grading designation of not lower than one level one level below the required grading designation in the class of construction works under consideration and possesses the required recognition status; and
3. the combined Contractor grading designation calculated in accordance with the Construction Industry Development Regulations is equal to or higher than a Contractor grading designation determined in accordance with the sum tendered for a **7EP or Higher** class of construction work or a value determined in accordance with Regulation 25(1B) or 25(7A) of the Construction Industry Development Regulations
4. the Contractor shall provide the employer with a certified copy of its signed joint venture agreement;
5. and in the event that the joint venture is an 'Incorporated Joint Venture' the Memorandum of Incorporation to be provided within 4 (four) weeks of the Contract Date.

## T2.2-02: Evaluation Schedule: Project Schedule/Programme

### Note to tenderers:

#### Programme

**The Tenderer details the programme for evaluation and attaches it to this schedule. In addition, the Tenderer is to provide a hard copy of the programme in Primavera or MS project format.**

The Tenderer's attention is drawn to core clause 31 of the NEC3 Engineering and Construction Contract regarding the items to be shown on a programme.

The Programme should indicate the following columns as a bare minimum:

Task ID	Task description	Start date	Finish date	Successor	Resources & Equipment	Time risk allowances (TRA)
---------	------------------	------------	-------------	-----------	-----------------------	----------------------------

The tenderer shall provide the proposed programme, at a minimum **Level 3** showing but not limited to the following:

- **Meet the required timeframes:**

Ability to provide the services in terms of the *Employer's* requirements within the required timeframe as stated in the Works Information and Tender Data by indicating, in a logical sequence, the order, the timing, and the duration of the works that will take place in order to Provide the Works. The Programme must clearly support and demonstrate alignment to the approach paper/Method statement as contained under T.2.2-05.

- **Programme Information:**

The Tenderer clearly indicates in the schedule all milestones, activities & information related to the following –

1. Float,
2. Time Risk Allowances,
3. Health and safety requirements,
4. Procedures set out in this contract,
5. Work by the Employer and Others,
6. Access to a part of the site if later than its access date,
7. Acceptances,
8. Plant & Materials and other things to be provided by the employer,
9. Information by Others,
10. starting date, access dates, Key Dates and Completion Date
11. planned Completion for each Key Date for each option and the complete works
12. Shows how each activity on the Activity Schedule relates to the operations on each programme

The scoring of the Programme will be as follows:

	<b>Meet the required timeframes (8)</b>	<b>Programme Information (2)</b>
<b>Score 0%</b>	The tenderer has submitted no information or inadequate information to determine a score.	The tenderer has submitted no information or inadequate information to determine a score.
<b>Score 20%</b>	The programme does not meet any of the required timeframes, key dates and completion dates	The tenderer has addressed some but not all data requirements as listed in this returnable <b>(4 or less of 12 addressed)</b>
<b>Score 40%</b>	The programme does not meet all <b>(less than 40%)</b> of the required timeframes, key dates and completion dates	The tenderer has addressed some but not all data requirements as listed in this returnable <b>(5 to 6 of 12 addressed)</b>
<b>Score 60%</b>	The programme does not meet all <b>(more than 40%, but less than or equal to 60%)</b> of the required timeframes, key dates and completion dates	The tenderer has addressed most but not all data requirements as listed in this returnable <b>(7 to 8 of 12 addressed)</b>
<b>Score 80%</b>	The programme does meet all <b>(more than 60%, but less than or equal to 99%)</b> of the required timeframes, key dates and completion dates	The tenderer has addressed most but not all data requirements as listed in this returnable <b>(9 to 10 of 12 addressed)</b>
<b>Score 100%</b>	The programme does meet <b>All</b> of the required timeframes, key dates and completion dates.	The tenderer has addressed all data requirements as listed in this returnable <b>(11 to 12 of 12 addressed)</b>

Signed

Date

.....

.....

Name

Position

.....

.....

Tenderer

.....

## T2.2-03: Evaluation Schedule – Quality Management

The tenderer is to note that if successful, and awarded the contract, shall execute, and complete the contract as per the **STD-QAL-0001** Quality Management Specification for Supplier/Construction.

The tenderer shall as a minimum submit the following:

- Project Quality Plan which satisfies the technical and quality requirements of the *works*, identifying all procedures, reviews, audits, controls, and records used to control and verify compliance with the Works Information.
- Project specific Quality data book index (index/list of procedures and method statements to be used during the contract).
- Qualifications and experience of quality personnel. Attach minimum qualifications as listed below:
- Index/List of procedures and method statements to be used during the contract.
- Quality Control Plans Specific to the Works Information not limited to the following.
  - These Q.C.P's shall identify all inspections, tests and verification requirements to meet Contractual obligations, specifications and related details including destructive and non-destructive testing, witnessing and hold points.
- A Guarantee period on the Switchgear of not less than five years on corrosion protection is required.
- Guarantee period on the Substation of not less than one year on workmanship is required.

Item	Guarantee and Warrantee period	Description of Guarantee

- A signed Quality Policy based on International Organisation for Standardisation (ISO 9001:2015) that displays the five key policy requirements. These requirements include:
  1. Is appropriate to the purpose of the organisation,
  2. Includes a commitment to comply with requirements and continually improve the effectiveness of the quality management system,
  3. Provides a framework for establishing and reviewing quality objectives,
  4. Is communicated and understood within the organisation, and
  5. Is reviewed for continuing suitability.

<p><b>Attached submissions to this schedule:</b></p> <p>.....</p> <p>.....</p> <p>.....</p> <p>.....</p>
--

The scoring of the Quality Management will be as follows:

	<b>Project Specific Quality Management Plan for the contract</b>	<b>Project Specific Quality Data Book Index</b>	<b>Procedures and Method statements to be used</b>	<b>Order and timing of the audits, inspection and design milestones that will take place to provide the works.</b>	<b>Project specific Quality Control Plan</b>
<b>Points</b>	<b>2</b>	<b>2</b>	<b>2</b>	<b>2</b>	<b>2</b>
<b>0</b>	No PQP submitted.	No Quality Data Book Index submitted	No list of QMS procedures and method statement (MS) submitted	No audit schedule submitted	No QCPs submitted.
<b>20</b>	PQP does not meet ISO 10005:2018 requirements nor covers the project scope	Quality Data book index is does not cover project scope	Index / list of QMS procedures and method statement is not project specific as per ISO 9001:2015/O.E.M. certification or equivalent	Audit Schedule does not cover quality audit requirements of the project scope.	QCPs do not cover project scope.
<b>40</b>	PQP covers the project scope and partially meets ISO 10005:2018 Project Quality Plan requirements	Quality Data book index is project specific but inadequate to cover project scope. Only one (1) discipline covered	Index / list of QMS procedures and method statements is inadequate to cover project scope as per ISO 9001:2015/O.E.M. certification or equivalent. MS list covers Only one (1) discipline.	The Audit Schedule is inadequate to cover most of the quality audit (Not all disciplines and covered).	QCPs are project specific but inadequate to cover project scope. Only one (1) discipline covered
<b>60</b>	PQP meets ISO 10005:2018 requirements and covers the project scope	Data book index shows adequate understanding of project quality requirements. Only two (2) disciplines covered	Index / list of QMS procedures and method statements partially covers project scope requirements as per ISO 9001:2015/O.E.M. certification or equivalent. MS list	The Audit Schedule has adequate audits to cover most audit quality requirements for the project scope	QCP's shows adequate understanding of project quality requirements. Only two (2) disciplines covered

	<b>Project Specific Quality Management Plan for the contract</b>	<b>Project Specific Quality Data Book Index</b>	<b>Procedures and Method statements to be used</b>	<b>Order and timing of the audits, inspection and design milestones that will take place to provide the works.</b>	<b>Project specific Quality Control Plan</b>
<b>Points</b>	<b>2</b>	<b>2</b>	<b>2</b>	<b>2</b>	<b>2</b>
			covers Only two (2) disciplines		
<b>80</b>	PQP is fully meets ISO 10005:2018 Project Quality Plan requirements.	Data book index shows above average understanding of the project quality requirements. All disciplines covered.	Index / list of QMS procedures and method statements fully covers all project scope requirements as per ISO 9001:2015/O.E.M. certification or equivalent. MS list covers all disciplines	The Audit Schedule covers all the required audit requirements for the project scope. All clauses of ISO 9001 are covered. All disciplines covered	QPC's shows above average understanding of the project quality requirements, All disciplines covered.
<b>100</b>	PQP fully meets ISO 10005:2018 Project Quality Plan requirements and makes references all relevant QMS specifications and standards.	The Data book index covers all disciplines including all relevant tests and certifications to be provided.	Index / list of procedures and method statements covers all project scope requirements as per ISO 9001:2015/O.E.M. certification or equivalent. MS list covers all disciplines as well as list relevant check sheets / forms.	The Audit Schedule exceeds the required quality audit requirements of the scope. All clauses of ISO 9001 are covered. All disciplines covered	QCP's covers all disciplines and intervention points with reference to standards, specifications, drawings, etc.



TRANSNET PORT TERMINALS  
TENDER NUMBER: iCLM EL 725/TPT

DESCRIPTION OF THE WORKS: THE REFURBISHMENT OF THE GRAIN ELEVATOR SUBSTATIONS AT THE EAST LONDON MULTI PURPOSE TERMINAL FOR TRANSNET SOC LTD (REG NO. 1990/000900/30) OPERATING AS TRANSNET PORT TERMINALS (HEREINAFTER REFERRED AS "TPT") FOR THE DURATION OF 12 MONTHS

---

Signed

Date

.....

.....

Name

Position

.....

.....

Tenderer

.....

## T2.2-04: Evaluation Schedule - Previous Experience

### Note to Tenderers:

Tenderers are required to demonstrate their past experience in the delivery of similar projects "of a minimum value of R8m per project" areas, conditions and circumstances in relation to the scope of work in the last 10 years, and to this end shall supply a sufficiently detailed reference list with contact details for tracing and verification of customers, indicate previous experience, and provide completion certificates. Tenderers are required to provide sufficient information about the reference work previously undertaken because only references that are similar to the scope of work of this contract will be considered for evaluation.

### Please provide your previous experience showing but not limited to the following:

- Electrical MV and LV infrastructure Installation Works: LV/MV Power system studies, Design, installations, commissioning of MV/LV reticulation and distribution systems, LV/MV cable laying, splicing, transformer refurbishments, power quality installations, termination and installation inside substation buildings.
- Earthing and lightning protection, power system modelling and simulation: Design, supply and installation of Lightning protection and Earthing of buildings and structures. Proof of design reports, accreditation of specialist person and company shall be submitted for evaluation. Previously conducted power system modelling and simulation studies related to the SoW.
- Automatic fire smoke detection and suppression system, HVAC: Type of fire protection designs, installation, testing, commissioning, gas plant and equipment. Provide evidence for previously undertaking the design, supply, and installation of the HVAC or climate control system.

Fill in as many line items as needed for the similar previous projects undertaken, starting from the most recent projects completed:

Client	Client contact details	Project Description	Year of project completion	Contract Value	Subcontractors

**Index of documentation attached to this schedule:**

.....

.....

.....

.....

The scoring of the Previous Experience will be as follows and in particular, the tenderers shall demonstrate their experience in the following areas:

	<b>Electrical MV 70% and LV 30% infrastructure works</b>	<b>Earthing and lightning protection 30%, and power systems modelling and simulation 70%</b>	<b>Automatic fire smoke detection and suppression system 50%, HVAC 50%</b>
<b>25 Points</b>	<b>12</b>	<b>8</b>	<b>5</b>
<b>(score 0%)</b>	The tenderer has submitted no information or inadequate information to determine a score.		
<b>(score 20%)</b>	The tenderer has sufficient experience in relation to the project and has worked previously under similar conditions and circumstances, and has successfully completed more than 1 similar projects.		
<b>(score 40%)</b>	The tenderer has sufficient experience in relation to the project and has worked previously under similar conditions and circumstances, and has successfully completed more than 2 similar projects.		
<b>(score 60%)</b>	The tenderer has sufficient experience in relation to the project and has worked previously under similar conditions and circumstances, and has successfully completed more than 3 similar projects.		
<b>(score 80%)</b>	The tenderer has sufficient experience in relation to the project and has worked previously under similar conditions and circumstances, and has successfully completed more than 4 similar projects.		
<b>(score 100%)</b>	The tenderer has sufficient experience in relation to the project and has worked previously under similar conditions and circumstances, and has successfully completed more than 5 similar projects.		

The undersigned, who warrants that he / she is duly authorised to do so on behalf of the enterprise, confirms that the contents of this schedule are within my personal knowledge and are to the best of my belief both true and correct.

Signed \_\_\_\_\_ Date \_\_\_\_\_

Name \_\_\_\_\_ Position \_\_\_\_\_

Tenderer \_\_\_\_\_

## **T2.2-05: Evaluation Schedule – Method Statement**

Method statement which responds to the scope of work and outlines proposed approach / methodology including that relating but not limited to programme, method statement, technical approach, and an understanding of the project objective.

The method statement should articulate what the Tenderer will provide in achieving the stated objectives for the project which should include a high-level project schedule which is aligned to the programme. Tenderers to also exhibit a clear understanding of the scope of works and has shown a concise method statement for all activities incorporating best practice.

The Tenderer must as such explain his / her understanding of the objectives of the works and the Employer's stated and implied requirements, highlight the issues of importance, and explain the technical approach and methodology they would adopt to address them. The method statement should explain the methodologies which are to be adopted and demonstrate its compatibility. The approach should also include and outline processes, procedures, and associated resources, to meet the requirements and indicate how risks will be managed. Consideration should be made to design objectives with respect to the legislations and compliance standards.

The method statement should also include a cash flow based on the tenderer's programme. The tenderer must attach his / her method statement to this page. The method statement should not be longer than 10 pages.

Tenderer shall attach the form of offer or general arrangements for plant and/or technology to demonstrate compliance to scope and an understanding of the employer's requirements.

The method statement should cover:

- Outline of proposed approach
- Narrative related to the programme
- Detailed method statement, technical approach, and construction sequencing in terms of the Works Information (design philosophy)
- Demonstrate an understanding of the project objectives.
- Detailed list of equipment, plant and people and number thereof to execute the works, and areas it will be utilised.
- Detailed list of other resources utilised including a resource matrix.

The Tenderer must attach his / her method statement to this page.

TRANSNET PORT TERMINALS

TENDER NUMBER: iCLM EL 725/TPT

DESCRIPTION OF THE WORKS: THE REFURBISHMENT OF THE GRAIN ELEVATOR SUBSTATIONS AT THE EAST LONDON MULTI PURPOSE TERMINAL FOR TRANSNET SOC LTD (REG NO. 1990/000900/30) OPERATING AS TRANSNET PORT TERMINALS (HEREINAFTER REFERRED AS "TPT") FOR THE DURATION OF 12 MONTHS

The method statement shall include as a minimum but not limited to the following (the contractor must refer to the Works Information for a full description of the scope of the works):

- a. Power system Survey
- b. MV and LV installations in Substations by Certified Personnel.
- c. Provide details of the form of offer for switchgear in relation to the employer's specifications. General arrangements and data sheets.
- d. MV and LV cable laying, tracing, jointing and termination.
- e. Power systems load flow studies and protection grading.
- f. Installations of earthing, bonding, and lightning protection systems.
- g. Installation of MV and LV cable ways, cable trays and cable management systems.
- h. Installation of electrical infrastructure in buildings and structures.
- i. Installation of conduit and conduit systems.
- j. Rigging of heavy electrical equipment.
- k. Changing of transformer oil.
- l. Design, supply, and installation of the HVAC.
- m. Design, supply and installation of the fire detection and suppression system.

<p><b>Index of documentation attached to this schedule:</b></p> <p>.....</p> <p>.....</p> <p>.....</p> <p>.....</p> <p>.....</p> <p>.....</p> <p>.....</p> <p>.....</p> <p>.....</p> <p>.....</p> <p>.....</p>
--

The scoring of the approach paper will be as follows:

Elements:	Weight	Clearly articulated and based on the Works Information which includes the design, general arrangements of switchgear, power system study investigations and criteria. Approach to ensuring less disruption to operations.	Demonstrates a clear understanding of the project objectives and the employer's specifications. Clear construction, and commissioning methodology. Outline the project specific requirements of the SHEQ requirements.
	<b>20 Points</b>	<b>8</b>	<b>12</b>
	<b>Score</b>		
<b>Electrical MV and LV infrastructure Installation Works (60%)</b>  <b>Power system modelling and simulation (20%)</b>  <b>Installation of automatic fire/smoke detection and suppression system, and HVAC (20%)</b>	<b>0%</b>	The Tenderer has submitted no information or inadequate information to determine a score.	
	<b>20%</b>	The approach paper is not acceptable as it will not satisfy project objectives or requirements. The tenderer has misunderstood the scope of work and does not deal with the critical aspects of the project.	
	<b>40%</b>	The technical approach and / or methodology is poor, not realistic, and practical and is therefore unlikely to satisfy project objectives or requirements. The tenderer has misunderstood certain aspects of the scope of work and does not deal with the critical aspects of the project.	
	<b>60%</b>	The approach is generic and not tailored to address the specific project objectives and requirements. The approach does not adequately deal with the critical characteristics of the project. The approach to managing risk is too generic.	
	<b>80%</b>	The approach is specifically tailored to address the specific project objectives and methodology and is sufficiently flexible to accommodate changes that may occur during execution. The approach to managing risk etc. is specifically tailored to the critical characteristics of the project.	
	<b>100%</b>	Besides meeting the "80" rating, the important issues are approached in an innovative and efficient way, indicating that the tenderer has outstanding knowledge of state-of-the-art approaches.  The approach paper details ways to improve the project outcomes and the quality of the outputs.	

TRANSNET PORT TERMINALS

TENDER NUMBER: iCLM EL 725/TPT

DESCRIPTION OF THE WORKS: THE REFURBISHMENT OF THE GRAIN ELEVATOR SUBSTATIONS AT THE EAST LONDON MULTI PURPOSE TERMINAL FOR TRANSNET SOC LTD (REG NO. 1990/000900/30) OPERATING AS TRANSNET PORT TERMINALS (HEREINAFTER REFERRED AS "TPT") FOR THE DURATION OF 12 MONTHS

---

The undersigned, who warrants that he / she is duly authorised to do so on behalf of the enterprise, confirms that the contents of this schedule are within my personal knowledge and are to the best of my belief both true and correct.

Signed

Date

.....

Name

Position

.....

Tenderer

.....

## T2.2-06: Evaluation Schedule: Management & CV's of Key Persons

Please describe the management arrangements for the *works* and the tenderer is to take note that evaluation of this schedule must contain the following information:

Comprehensive CV's should be attached to this schedule:

As a minimum each CV should address the following, but not limited to;

1. Personal particulars;
2. Qualifications (degrees, grades of membership of professional societies and Professional registrations, all these certificates are to be attached);
3. Skills (attach certificates of short courses and training obtained);
4. Name of current employer and position;
5. Overview of post graduate experience (year, organisation, position and responsibilities); and
6. Outline of recent assignments / detailed experience that has a bearing on the scope of work.
7. CV's for people proposed for all identified posts including:

i) **Project Manager**

The Project Manager should at least have a minimum qualification of a BSc. Eng./ B.Tech./ National Diploma in Engineering and a SACPMP registration/Pr. CPM/PMP with at least 5 years post registration experience in Electrical MV/LV and building construction projects. The Project Manager must have experience working in at least 3 separate projects, with at least 1 project in excess of R10m in electrical works (MV and LV switchgear, and power transformer installation) component value.

ii) **Contract Manager**

The Contract Manager or Site Agent must at least have a minimum qualification of a National Diploma in Electrical Engineering with a PR registration with ECSA as a Pr Tech Eng, with at least 5 years' post registration experience in electrical MV/LV substation design and construction. The Contract Manager or Site Agent must have experience working in at least one substation project with MV and LV switchgear scope in excess of R10 million.

iii) **Mechanical Engineer**

The Mechanical Engineer must at least have a minimum qualification of a National Diploma in Electrical Engineering with a PR registration with ECSA as a Pr Tech Eng, with at least 5 years' post registration experience in HVAC and Fire Protection design and installation.

iv) **Protection Engineer/Specialist**

The Protection Engineer must at least have a minimum qualification of a National Diploma in Electrical/Electronic Engineering with a PR registration with ECSA as a Pr Tech Eng, with at least 5 years' post registration experience in electrical MV/LV substation protection and SCADA. The protection specialist must have done a protection grading study, and load flow analysis for a power system network similar to the requirement of the scope of this project with experience in ETAP or a similar software.

v) **Installation Electrician**

The Installation Electrician must have a minimum N6 qualification, an Electrical trade, registration with the department of Labour and have at least 5 years' in MV/LV Switchgear installations. The Installation Electrician must have experience working in at least one substation project with MV and LV switchgear scope in excess of R10 million.

8. Details of experience for proposed staff working in similar projects in terms of nature, competency and value.
9. An explanation of how you propose to allocate adequate resources to enable you to comply with the requirements and prohibitions imposed on you by or under the statutory provisions relating to health and safety.
10. Details of experience for proposed staff in respect of NEC3 Engineering & Construction Contract option chosen for this Contract. If staff experience is limited, an indication of relevant training that they have attended would be helpful.

<p><b>Attached submissions to this schedule:</b></p> <p>.....</p> <p>.....</p> <p>.....</p> <p>.....</p>
--

The scoring of the Management & CV's of Key Persons will be as follows:

<b>Weight</b>	<b>Relevant Technical experience:</b>	<b>Education, training and skills for the following:</b>	<b>Knowledge of issues pertinent to the project for the following:</b>
	<b>Management and Engineering = 100%</b>	<b>Management and Engineering = 100%</b>	<b>Management and Engineering = 100%</b>
10%	10% Project Manager	10% Project Manager	10% Project Manager
30%	30% Contract Manager	30% Contract Manager	30% Contract Manager
20%	20% Protection Specialist	20% Protection Specialist	20% Protection Specialist
20%	20% Mechanical Engineer	20% Mechanical Engineer	20% Mechanical Engineer
20%	20% Installation Electrician	20% Installation Electrician	20% Installation Electrician
<b>Points</b>	<b>7</b>	<b>8</b>	<b>10</b>

<b>(score 0%)</b>	Failed to provide information or inadequate information provided to determine a score	Failed to provide information or inadequate information provided to determine a score	Failed to provide information or inadequate information provided to determine a score
<b>(score 20%)</b>	Key staff do not have relevant levels of relevant experience.	Key staff does not have project specific education, skills, training and experience as indicated above.	Key staff has no experience of issues pertinent to the project.
	<ul style="list-style-type: none"> <li>▪ Project Manager: <b>≥1 &lt; 3 years</b></li> <li>▪ Construction Manager: <b>≥1 &lt; 3 years</b></li> <li>▪ Protection Specialist: <b>≥1 &lt; 3 years</b></li> <li>▪ Mechanical Engineer: <b>≥1 &lt; 3 years</b></li> <li>▪ Installation Electrician: <b>≥1 &lt; 3 years</b></li> </ul>		
<b>(score 40%)</b>	Key staff have limited levels of general experience	Key staff have limited levels of project specific education, skills, training and experience	Key staff have limited experience of issues pertinent to the project
	<ul style="list-style-type: none"> <li>▪ Project Manager: <b>≥ 3 &lt; 5 years</b></li> <li>▪ Construction Manager: <b>≥ 3 &lt; 5 years</b></li> <li>▪ Protection Specialist: <b>≥ 3 &lt; 5 years</b></li> <li>▪ Mechanical Engineer: <b>≥ 3 &lt; 5 years</b></li> <li>▪ Installation Electrician: <b>≥ 5 &lt; 10 years</b></li> </ul>		
<b>(score 60%)</b>	Key staff have reasonable levels of general experience	Key staff have reasonable levels of project specific education, skills, training and experience	Key staff have reasonable experience of issues pertinent to the project
	<ul style="list-style-type: none"> <li>▪ Project Manager: <b>≥ 5 &lt; 8 years</b></li> <li>▪ Construction Manager: <b>≥ 5 &lt; 8 years</b></li> <li>▪ Protection Specialist: <b>≥ 5 &lt; 8 years</b></li> <li>▪ Mechanical Engineer: <b>≥ 5 &lt; 8 years</b></li> <li>▪ Installation Electrician: <b>≥ 10 &lt; 12 years</b></li> </ul>		
<b>(score 80%)</b>	Key staff have extensive levels of general experience	Key staff have extensive levels of project specific education, skills, training and experience	Key staff have extensive experience of issues pertinent to the project
	<ul style="list-style-type: none"> <li>▪ Project Manager: <b>≥ 8 &lt; 12 years</b></li> <li>▪ Construction Manager: <b>≥ 8 &lt; 12 years</b></li> <li>▪ Protection Specialist: <b>≥ 8 &lt; 12 years</b></li> <li>▪ Mechanical Engineer: <b>≥ 8 &lt; 12 years</b></li> <li>▪ Installation Electrician: <b>≥ 12 &lt; 15 years</b></li> </ul>		
<b>(score 100%)</b>	Key staff have outstanding levels of general experience	Key staff have outstanding levels of project specific education, skills, training and experience	Key staff have outstanding experience of issues pertinent to the project

	<ul style="list-style-type: none"><li>▪ Project Manager: <b>≥ 12 years</b></li><li>▪ Construction Manager: <b>≥ 12 years</b></li><li>▪ Protection Specialist: <b>≥ 12 years</b></li><li>▪ Mechanical Engineer: <b>≥ 12 years</b></li><li>▪ Installation Electrician: <b>≥ 15 years</b></li></ul>
--	--

The undersigned, who warrants that he / she is duly authorised to do so on behalf of the enterprise, confirms that the contents of this schedule are within my personal knowledge and are to the best of my belief both true and correct.

Signed \_\_\_\_\_ Date \_\_\_\_\_  
Name \_\_\_\_\_ Position \_\_\_\_\_  
Tenderer \_\_\_\_\_



## T2.2-07: Evaluation Schedule: Health and Safety Management

Submit the following documents as a minimum with your tender:

1. The Tenderer must provide their Contract specific health and safety plan addressing the requirements of TPT health and safety specification and include the following documents:
  - Health and Safety Company Policy signed by the accounting officer and dated (OHS Act, 16.2 appointee) List the five elements -
    - Commitment to Safety, prevention of pollution,
    - Continual improvement,
    - Compliance to legal requirements, appropriate to the nature of contractor's activities,
    - Hold management accountable for development of the safety systems.
    - Include objectives and targets.
2. Roles and responsibilities of legal appointees in terms of OHS Act 85 of 1993 and its Regulations.
  - i. S16.1 CEO,
  - ii. S16.2 Assistant to CEO,
  - iii. CR8.1 Construction manager, registered with a registered body,
  - iv. CR8.2 Assistant Construction manager,
  - v. CR8.5 Construction Health & Safety officer, With CV and Proof of registration with SACPCMP
  - vi. CR8.7 Construction Supervisor,
  - vii. CR8.8 Construction assistant supervisor,
  - viii. CR9.1 Risk Assessor
3. List of job categories for project and competencies required per category and develop a training Matrix for all employees who will be working on the project. This matrix must include Management and highlight training planned dates.
4. Overview of the tenderer's Risk Assessment methodology, and submission of **project specific risk assessments** indicating major activities of the project to be undertaken.
5. Two years synopsis of SHE incidents, description, type, and action taken to prevent re-occurrence.
6. Submission of completed cost breakdown sheet.
7. Complete and return with tender documentation the Contractor Safety Questionnaire with supporting documentation included as an Annexure.

<b>Attached submissions to this schedule:</b> ..... ..... .....
--

**The scoring of the Tenderer's Health and safety requirements will be as follows:**

	<p><b>Health and Safety Company Policy signed by the accounting officer and dated (OHS Act, 16.2 appointee) List the five elements:</b></p> <ol style="list-style-type: none"> <li><b>1. Commitment to Safety, prevention of pollution,</b></li> <li><b>2. Continual improvement,</b></li> <li><b>3. Compliance to legal requirements, appropriate to the nature of contractor's activities,</b></li> <li><b>4. Hold management accountable for development of the safety systems.</b></li> </ol>	<p><b>Roles &amp; Responsibility : S16.1 CEO,</b></p> <p><b>S16.2 Assistant to CEO,</b></p> <p><b>CR8.1 Construction manager, Registered with a registered body,</b></p> <p><b>CR8.2 Assistant Construction manager,</b></p> <p><b>CR8.5 Construction Health &amp; Safety officer, With CV and Proof of registration with SACPCMP</b></p>	<p><b>List of key responsible persons (job categories) for the project and health and safety competencies required per category (Training matrix)</b></p>	<p><b>Overview of the tenderer's Risk Assessment methodology, and submission of project specific risk assessments indicating major activities of the project to be undertaken.</b></p>	<p><b>Two years synopsis of SHE incidents, description, type, and action taken to prevent re-occurrence.</b></p>	<p><b>Submission of completed cost breakdown sheet.</b></p>	<p><b>Complete and return with tender documentation the Contractor Safety Questionnaire with required supporting documentation included as an Annexure.</b></p>
--	---	---	---	--	--	---	---

	<b>5. Include objectives and targets.</b>	<b>CR8.7 Construction Supervisor,</b> <b>CR8.8 Construction assistant supervisor,</b> <b>CR9.1 Risk Assessor</b>					
<b>Points</b>	<b>1</b>	<b>2</b>	<b>1</b>	<b>2</b>	<b>1</b>	<b>1</b>	<b>2</b>
<b>(score 0)</b>	The Tenderer has submitted no information or inadequate information to determine a score.						
<b>(score 20)</b>	1 of the 5 key policy components are recognized and meet the <i>Employer's</i> requirement.	Roles and responsibilities do not meet the Occupational health and safety Act as per construction regulations and TPT health and safety specification.	Key responsible persons are not included on training matrix as per proposed organogram structure.	Information supplied is very insignificant/inadequate to achieve the required standard of service.	Information supplied is very insignificant/inadequate to achieve the required standard of service.	Health and safety Budget submitted is very insignificant/inadequate to achieve the required standard of service, 0 to 1% allocated.	Information supplied is very insignificant/inadequate to achieve the required standard of service.
<b>(score 40)</b>	2 of the 5 key policy components are recognized and meet the <i>Employer's</i> requirement.	Roles and responsibilities are unlikely to ensure compliance as per the Works information and	Not all key responsible persons are included in the training matrix. Trainings matrix submitted does not cover all SHE is	Poor response/answer/solution lacks convincing evidence, medium risk that stated <i>employer's</i>	Poor response/answer/solution lacks convincing evidence, medium risk that stated	Health and safety Budget submitted is insignificant/inadequate /answer/solution to the returnable, <i>Employer's</i> health and safety requirements	Poor response/answer/solution lacks convincing evidence, medium risk that stated <i>Employer's</i>



		not in line with OHS Act and TPT health and safety specification.	training listed on Health and Safety specification. Training matrix not signed by responsible personnel.	requirements would not be met.	<i>Employer's</i> requirements would not be met.	will not be met, 1.1 – 2% allocated.	requirements would not be met.
<b>(score 60)</b>	3 of the 5 key policy components are recognized and meet the <i>Employer's</i> requirements.	Satisfactory response on roles and responsibilities as per <i>Employer's</i> requirements.	Satisfactory response on the list of job categories and trainings as per proposed project organogram structure. Training matrix covers most of the trainings listed on TPT Health and safety specification.	Satisfactory response/answer/solution to the aspect of the requirement, evidence given that the stated <i>Employer's</i> requirements will be met.	Satisfactory response/answer/solution to the aspect of the requirement, evidence given that the stated <i>Employer's</i> requirements will be met.	Health and safety Budget submitted is Satisfactory response/answer/solution to the returnable, <i>Employer's</i> health and safety requirements will be met, 2.1 – 3% allocated.	Satisfactory response/answer/solution to the aspect of the Requirement, evidence given that the stated <i>Employer's</i> requirements will be met.
<b>(score 80)</b>	4 of the five key policy components are recognized and meets the <i>Employer's</i> requirements.	Roles and responsibilities are likely to ensure compliance as per Works Information, OHS Act and TPT health and safety specification.	Most of key persons listed on the training matrix as per proposed project organogram structure. Trainings specified on the matrix are in line with TPT health and safety specification.	Good response/answer/solution, which demonstrates real understanding and evidence of ability to meet, stated <i>Employer's</i> requirements.	Good response/answer/solution, which demonstrates real understanding and evidence of ability to meet, stated <i>Employer's</i> requirements.	Health and safety Budget submitted is good response/answer/solution to the returnable, <i>Employer's</i> health and safety requirements will be met, 3% - above allocated.	Good response/answer/solution, which demonstrates real understanding and evidence of ability to meet, stated <i>Employer's</i> requirements.



<b>(score 100)</b>	All 5 key policy components are recognized and meets the <i>Employer's</i> requirements	Roles and Responsibilities most likely to ensure compliance as per requirements of OHS Act and TPT Health and Safety Management Specification and CV and proof of professional registration with SACPCMP submitted.	Training matrixes include Management and all employees /personnel in the project. Responsible personnel had signed training matrix.	Very good response/answer/solution gives real confidence that the tenderer is most likely to ensure compliance with stated <i>Employer's</i> requirements.	Very good response/answer/solution gives real confidence that the tenderer is most likely to ensure compliance with stated <i>Employer's</i> requirements.	Health and safety Budget submitted is Very good response/answer/solution to the returnable, Employer's health and safety requirements will be met, 4% - above allocated.	Very good response/answer/solution gives real confidence that the tenderer is most likely to ensure compliance with stated <i>Employer's</i> requirements.
--------------------	---	---	---	--	--	--	--



TRANSNET PORT TERMINALS

TENDER NUMBER: ICLM EL 725/TPT

DESCRIPTION OF THE WORKS: THE REFURBISHMENT OF THE GRAIN ELEVATOR SUBSTATIONS AT THE EAST LONDON MULTI PURPOSE TERMINAL FOR TRANSNET SOC LTD (REG NO. 1990/000900/30) OPERATING AS TRANSNET PORT TERMINALS (HEREINAFTER REFERRED AS "TPT") FOR THE DURATION OF 12 MONTHS

---

The undersigned, who warrants that he / she is duly authorised to do so on behalf of the enterprise, confirms that the contents of this schedule are within my personal knowledge and are to the best of my belief both true and correct.

Signed

Date

.....

.....

Name

Position

.....

.....

Tenderer

.....

## T2.2-08: Authority to submit a Tender

Indicate the status of the tenderer by ticking the appropriate box hereunder. The tenderer must complete the certificate set out below for his category of organisation or alternatively attach a certified copy of a company / organisation document which provides the same information for the relevant category as requested here.

<b>A - COMPANY</b>	<b>B - PARTNERSHIP</b>	<b>C - JOINT VENTURE</b>	<b>D - SOLE PROPRIETOR</b>

### A. Certificate for Company

I, \_\_\_\_\_ chairperson of the board of directors \_\_\_\_\_  
\_\_\_\_\_, hereby confirm that by resolution of the  
board taken on \_\_\_\_\_ (date), Mr/Ms \_\_\_\_\_,  
acting in the capacity of \_\_\_\_\_, was authorised to sign all  
documents in connection with this tender offer and any contract resulting from it on behalf of  
the company.

Signed

Date

Name

Position

Chairman of the Board of Directors



## B. Certificate for Partnership

We, the undersigned, being the **key partners** in the business trading as \_\_\_\_\_

\_\_\_\_\_ hereby authorise Mr/Ms \_\_\_\_\_

acting in the capacity of \_\_\_\_\_, to sign all documents in

connection with the tender offer for Contract \_\_\_\_\_ and any

contract resulting from it on our behalf.

Name	Address	Signature	Date

**NOTE:** This certificate is to be completed and signed by the full number of Partners necessary to commit the Partnership. Attach additional pages if more space is required.

### C. Certificate for Joint Venture

We, the undersigned, are submitting this tender offer in Joint Venture and hereby authorise

Mr/Ms \_\_\_\_\_, an authorised signatory of the company

\_\_\_\_\_, acting in the capacity of lead partner, to sign all documents in connection with the tender offer for Contract \_\_\_\_\_

\_\_\_\_\_ and any contract resulting from it on our behalf.

This authorisation is evidenced by the attached power of attorney signed by legally authorised signatories of all the partners to the Joint Venture.

Furthermore we attach to this Schedule a copy of the joint venture agreement which incorporates a statement that all partners are liable jointly and severally for the execution of the contract and that the lead partner is authorised to incur liabilities, receive instructions and payments and be responsible for the entire execution of the contract for and on behalf of any and all the partners.

<b>Name of firm</b>	<b>Address</b>	<b>Authorising signature, name (in caps) and capacity</b>



#### **D. Certificate for Sole Proprietor**

I, \_\_\_\_\_, hereby confirm that I am the sole owner of the business trading as \_\_\_\_\_.

Signed

Date

Name

Position

Sole Proprietor

## T2.2-09: Record of Addenda to Tender Documents

This schedule as submitted confirms that the following communications received from the *Employer* before the submission of this tender offer, amending the tender documents, have been taken into account in this specific tender offer:

	<b>Date</b>	<b>Title or Details</b>
1		
2		
3		
4		
5		
6		
7		
8		
9		
10		
11		
12		
13		
14		
15		

Attach additional pages if more space is required.



## **T2.2-10 Letter/s of Good Standing with the Workmen's Compensation Fund**

Attached to this schedule is the Letter/s of Good Standing.

- 1.
- 2.
- 3.
- 4.

Name of Company/Members of Joint Venture:

.....
.....
.....
.....
.....
.....
.....
.....
.....
.....
.....



TRANSNET PORT TERMINALS  
 TENDER NUMBER: iCLM EL 725/TPT  
 DESCRIPTION OF THE WORKS: THE REFURBISHMENT OF THE GRAIN ELEVATOR SUBSTATIONS AT THE EAST LONDON MULTI PURPOSE TERMINAL FOR TRANSNET SOC LTD (REG NO. 1990/000900/30) OPERATING AS TRANSNET PORT TERMINALS (HEREINAFTER REFERRED AS "TPT") FOR THE DURATION OF 12 MONTHS

## T2.2-12: Details of Plant Offered

**Note to Tenderer:**

Tenderers are required to submit the form of offer for critical plant. This will be used to evaluate the compliance to the employers works information. Where there is/are material deviation/s from the employers WI requirements, the Bid will be considered unacceptable.

- Tenderers to submit the details of offer for MV Switchgear.
- Tenderers to submit the details of offer for terminations.
- Tenderers to submit the details of offer for fire suppression technology.

#	Description.	Compliance requirement.	Complies fully with the WI. Yes/No	Comments
1	MV Switchgear	As per the WI		
2	Terminations	As per the WI		
3	Fire suppression	As per the WI		

Signed

Date

\_\_\_\_\_

\_\_\_\_\_

Name

Position

\_\_\_\_\_

\_\_\_\_\_

Tenderer

\_\_\_\_\_

## T2.2-13: Schedule of Proposed Subcontractors

The tenderer is required to provide details of all the sub-contractors that will be utilised in the execution of the *works*.

### Note to tenderers:

- In terms of PPPFA Regulation 6 (5), A tenderer may not be awarded points for B-BBEE status level of contributor if the tender documents indicate that the tenderer intends subcontracting more than 25% of the value of the contract to any other person not qualifying for at least the points that the tenderer qualifies for, unless the intended subcontractor is an EME that has the capability to execute the subcontract.
- In terms of PPPFA Regulation 12 (3), A person awarded a contract may not subcontract more than 25% of the value of the contract to any other enterprise that does not have an equal or higher B-BBEE status level of contributor that the person concerned, unless the contract is subcontracted to an EME that has the capability and ability to execute the contract.

**Tenderer to note that after award, any deviations from this list of proposed subcontractors will be subject to acceptance by the *Project Manager* in terms of the Conditions of Contract.**

Provide information of the Sub-contractors below:

Name of Proposed Subcontractor		Address		Nature of work		Amount of Worked	Percentage of work
% Black Owned	EME	QSE	Youth	Women	Disabilities	Rural/ Underdeveloped areas/ Townships	Military Veterans
	<input type="checkbox"/>	<input type="checkbox"/>	<input type="checkbox"/>	<input type="checkbox"/>	<input type="checkbox"/>	<input type="checkbox"/>	<input type="checkbox"/>

Name of Proposed Subcontractor		Address		Nature of work		Amount of Worked	Percentage of work
% Black Owned	EME	QSE	Youth	Women	Disabilities	Rural/ Underdeveloped areas/ Townships	Military Veterans
	<input type="checkbox"/>	<input type="checkbox"/>	<input type="checkbox"/>	<input type="checkbox"/>	<input type="checkbox"/>	<input type="checkbox"/>	<input type="checkbox"/>

DESCRIPTION OF THE WORKS: THE REFURBISHMENT OF THE GRAIN ELEVATOR SUBSTATIONS AT THE EAST LONDON MULTI PURPOSE TERMINAL FOR TRANSNET SOC LTD (REG NO. 1990/000900/30) OPERATING AS TRANSNET PORT TERMINALS (HEREINAFTER REFERRED AS "TPT") FOR THE DURATION OF 12 MONTHS

Name of Proposed Subcontractor			Address		Nature of work		Amount of Worked	Percentage of work
% Black Owned	EME	QSE	Youth	Women	Disabilities	Rural/ Underdeveloped areas/ Townships	Military Veterans	
	<input type="checkbox"/>	<input type="checkbox"/>	<input type="checkbox"/>	<input type="checkbox"/>	<input type="checkbox"/>	<input type="checkbox"/>	<input type="checkbox"/>	

Name of Proposed Subcontractor			Address		Nature of work		Amount of Worked	Percentage of work
% Black Owned	EME	QSE	Youth	Women	Disabilities	Rural/ Underdeveloped areas/ Townships	Military Veterans	
	<input type="checkbox"/>	<input type="checkbox"/>	<input type="checkbox"/>	<input type="checkbox"/>	<input type="checkbox"/>	<input type="checkbox"/>	<input type="checkbox"/>	



**T2.2-15: ANNEX G Compulsory Enterprise Questionnaire**

The following particulars hereunder must be furnished.

In the case of a Joint Venture, separate enterprise questionnaires in respect of each partner/member must be completed and submitted.

**Section 1: Name of enterprise:** \_\_\_\_\_

**Section 2: VAT registration number, if any:** \_\_\_\_\_

**Section 3: CIDB registration number, if any:** \_\_\_\_\_

**Section 4: CSD number:** \_\_\_\_\_

**Section 5: Particulars of sole proprietors and partners in partnerships**

Name	Identity number	Personal income tax number

\* Complete only if sole proprietor or partnership and attach separate page if more than 3 partners

**Section 6: Particulars of companies and close corporations**

Company registration number \_\_\_\_\_

Close corporation number \_\_\_\_\_

Tax reference number: \_\_\_\_\_

**Section 7: The attached SBD4 must be completed for each tender and be attached as a tender requirement.**

**Section 8: The attached SBD 6 must be completed for each tender and be attached as a requirement.**

The undersigned, who warrants that he / she is duly authorised to do so on behalf of the enterprise:

- i) authorizes the Employer to obtain a tax clearance certificate from the South African Revenue Services that my / our tax matters are in order;
- ii) confirms that the neither the name of the enterprise or the name of any partner, manager, director or other person, who wholly or partly exercises, or may exercise, control over the enterprise appears on the Register of Tender Defaulters established in terms of the Prevention and Combating of Corrupt Activities Act of 2004;
- iii) confirms that no partner, member, director or other person, who wholly or partly exercises, or may exercise, control over the enterprise appears, has within the last five years been convicted of fraud or corruption;
- iv) confirms that I / we are not associated, linked or involved with any other tendering entities submitting tender offers and have no other relationship with any of the tenderers or those responsible for compiling the scope of work that could cause or be interpreted as a conflict of interest; and
- v) confirms that the contents of this questionnaire are within my personal knowledge and are to the best of my belief both true and correct.

Signed	_____	Date	_____
Name	_____	Position	_____
Enterprise name	_____		

**SBD 6.1**

**PREFERENCE POINTS CLAIM FORM**

This preference form must form part of all bids invited. It contains general information and serves as a claim for preference points for Specific Goals contribution. Transnet will award preference points to companies who provide valid proof of evidence as per the table of evidence in paragraph 4.1 below.

**1. GENERAL CONDITIONS**

1.1 The following preference point systems are applicable to all bids:

- the 80/20 system for requirements with a Rand value of up to R50 000 000 (all applicable taxes included); and
- the 90/10 system for requirements with a Rand value above R50 000 000 (all applicable taxes included).

1.2 The value of this bid is estimated to not exceed R50 000 000 (all applicable taxes included) and therefore the 80/20 preference point system shall be applicable. Despite the stipulated preference point system, Transnet shall use the lowest acceptable bid to determine the applicable preference point system in a situation where all received acceptable bids are received outside the stated preference point system.

1.3 Preference points for this bid shall be awarded for:

- (a) Price;
- (b) B-BBEE Status Level of Contribution; and
- (c) Any other specific goal determined in the Transnet preferential procurement policy

1.4 The maximum points for this bid are allocated as follows:

	POINTS
<b>PRICE</b>	<b>80</b>
<b>SPECIFIC GOALS</b>	
<b>B-BBEE STATUS LEVEL OF CONTRIBUTION Level 1 or 2</b>	<b>10</b>
<b>EXEMPTED MICRO ENTERPRISES (EME'S) AND QUALIFYING SMALL BUSINESS ENTERPRISES (QSE'S) OWNED BY BLACK PEOPLE (AT LEAST 51% BLACK OWNED)</b>	<b>10</b>
<b>Total points for Price and B-BBEE must not exceed</b>	<b>100</b>

- 1.5 Failure on the part of a bidder to submit proof of evidence required for any of the specific goals together with the bid will be interpreted to mean that preference points for that specific goal are not claimed.
- 1.6 The purchaser reserves the right to require of a bidder, either before a bid is adjudicated or at any time subsequently, to substantiate any claim in regard to preferences, in any manner required by the purchaser.

## 2. DEFINITIONS

- (a) **"all applicable taxes"** includes value-added tax, pay as you earn, income tax, unemployment insurance fund contributions and skills development levies;
- (b) **"B-BBEE"** means broad-based black economic empowerment as defined in section 1 of the Broad-Based Black Economic Empowerment Act;
- (c) **"B-BBEE status level of contributor"** means the B-BBEE status received by a measured entity based on its overall performance using the relevant scorecard contained in the Codes of Good Practice on Black Economic Empowerment, issued in terms of section 9(1) of the Broad-Based Black Economic Empowerment Act;
- (d) **"bid"** means a written offer in a prescribed or stipulated form in response to an invitation by an organ of state for the supply/provision of services, works or goods, through price quotations, advertised competitive bidding processes or proposals;
- (e) **"Broad-Based Black Economic Empowerment Act"** means the Broad-Based Black Economic Empowerment Act, 2003 (Act No. 53 of 2003);
- (f) **"EME"** means an Exempted Micro Enterprise as defines by Codes of Good Practice under section 9 (1) of the Broad-Based Black Economic Empowerment Act, 2003 (Act No. 53 of 2003);
- (g) **"functionality"** means the ability of a bidder to provide goods or services in accordance with specification as set out in the bid documents
- (h) **"Price"** includes all applicable taxes less all unconditional discounts.
- (i) **"Proof of B-BBEE Status Level of Contributor"**
  - i) the B-BBBEE status level certificate issued by an authorised body or person;
  - ii) a sworn affidavit as prescribed by the B-BBEE Codes of Good Practice; or
  - iii) any other requirement prescribed in terms of the B-BBEE Act.
- (j) **"QSE"** means a Qualifying Small Enterprise as defines by Codes of Good Practice under section 9 (1) of the Broad-Based Black Economic Empowerment Act, 2003 (Act No. 53 of 2003);
- (k) **"rand value"** means the total estimated value of a contract in South African currency, calculated at the time of bid invitations, and includes all applicable taxes and excise duties.
- (l) **"Specific goals"** means targeted advancement areas or categories of persons or groups either previously disadvantaged or falling within the scope of the

Reconstruction and Development Programme identified by Transnet to be given preference in allocation of procurement contracts in line with section 2(1) of the PPPFA.

### 3. POINTS AWARDED FOR PRICE

#### 3.1 THE 80/20 PREFERENCE POINT SYSTEMS

A maximum of 80 points is allocated for price on the following basis:  
80/20

$$P_s = 80 \left( 1 - \frac{P_t - P_{\min}}{P_{\min}} \right)$$

Where

$P_s$  = Points scored for comparative price of bid under consideration

$P_t$  = Comparative price of bid under consideration

$P_{\min}$  = Comparative price of lowest acceptable bid

### 4. EVIDENCE REQUIRED FOR CLAIMING SPECIFIC GOALS

4.1 In terms of Transnet Preferential Procurement Policy (TPPP) and Procurement Manuals, preference points must be awarded to a bidder for providing evidence in accordance with the table below:

Specific Goals	Acceptable Evidence
B-BBEE Status contributor	B-BBEE Certificate / Sworn- Affidavit / B-BBEE CIPC Certificate (in case of JV, a consolidated scorecard will be accepted) as per DTIC guideline
EME or QSE 51% Black Owned	B-BBEE Certificate / Sworn-Affidavit / CIPC Certificate

4.2 The table below indicates the required proof of B-BBEE status depending on the category of enterprises:

Enterprise	B-BBEE Certificate & Sworn Affidavit
<b>Large</b>	Certificate issued by SANAS accredited verification agency
<b>QSE</b>	Certificate issued by SANAS accredited verification agency Sworn Affidavit signed by the authorised QSE representative and attested by a Commissioner of Oaths confirming annual turnover and black ownership (only black-owned QSEs - 51% to 100% Black owned) [Sworn affidavits must substantially comply with the format that can be obtained on the DTI's website at <a href="http://www.dti.gov.za/economic_empowerment/bee_codes.jsp">www.dti.gov.za/economic_empowerment/bee_codes.jsp</a> .]

<b>EME<sup>1</sup></b>	Sworn Affidavit signed by the authorised EME representative and attested by a Commissioner of Oaths confirming annual turnover and black ownership Certificate issued by CIPC (formerly CIPRO) confirming annual turnover and black ownership Certificate issued by SANAS accredited verification agency only if the EME is being measured on the QSE scorecard
------------------------	---

- 4.3 A trust, consortium or joint venture (including unincorporated consortia and joint ventures) must submit a consolidated B-BBEE Status Level verification certificate for every separate bid.
- 4.4 Tertiary Institutions and Public Entities will be required to submit their B-BBEE status level certificates in terms of the specialized scorecard contained in the B-BBEE Codes of Good Practice.
- 4.5 A person will not be awarded points for B-BBEE status level if it is indicated in the bid documents that such a bidder intends sub-contracting more than 25% of the value of the contract to any other enterprise that does not qualify for at least the points that such a bidder qualifies for, unless the intended sub-contractor is an EME that has the capability and ability to execute the sub-contract.
- 4.6 A person awarded a contract may not sub-contract more than 25% of the value of the contract to any other enterprise that does not have an equal or higher B-BBEE status level than the person concerned, unless the contract is sub-contracted to an EME that has the capability and ability to execute the sub-contract.
- 4.7 Bidders are to note that the rules pertaining to B-BBEE verification and other B-BBEE requirements may be changed from time to time by regulatory bodies such as National Treasury or the DTI. It is the Bidder's responsibility to ensure that his/her bid complies fully with all B-BBEE requirements at the time of the submission of the bid.

## 5. BID DECLARATION

- 5.1 Bidders who claim points in respect of B-BBEE Status Level of Contribution must complete the following:

## 6. B-BBEE STATUS LEVEL OF CONTRIBUTION CLAIMED IN TERMS OF PARAGRAPHS 1.4 AND 6.1

- 6.1 B-BBEE Status Level of Contribution: . = .....(maximum of 10 points)

(Points claimed in respect of paragraph 6.1 must be in accordance with the table reflected in paragraph 4.1 and must be substantiated by relevant proof of B-BBEE status level of contributor.

---

<sup>1</sup> In terms of Transnet Preferential Procurement Policy (TPPP) and Procurement Manuals, preference points must be awarded to a bidder for providing evidence in accordance with clause 4.1

**7. SUB-CONTRACTING**

7.1 Will any portion of the contract be sub-contracted?

( **Tick applicable box** )

YES	<input type="checkbox"/>	NO	<input type="checkbox"/>
-----	--------------------------	----	--------------------------

7.1.1 If yes, indicate:

- i) What percentage of the contract will be subcontracted.....%
- ii) The name of the sub-contractor.....
- iii) The B-BBEE status level of the sub-contractor.....
- iv) Whether the sub-contractor is an EME or QSE.

( **Tick applicable box** )

YES	<input type="checkbox"/>	NO	<input type="checkbox"/>
-----	--------------------------	----	--------------------------

v) Specify, by ticking the appropriate box, if subcontracting with any of the following enterprises:

Designated Group: An EME or QSE which is at last 51% owned by:	EME <input type="checkbox"/>	QSE <input type="checkbox"/>
Black people	<input type="checkbox"/>	<input type="checkbox"/>
Black people who are youth	<input type="checkbox"/>	<input type="checkbox"/>
Black people who are women	<input type="checkbox"/>	<input type="checkbox"/>
Black people with disabilities	<input type="checkbox"/>	<input type="checkbox"/>
Black people living in rural or underdeveloped areas or townships	<input type="checkbox"/>	<input type="checkbox"/>
Cooperative owned by black people	<input type="checkbox"/>	<input type="checkbox"/>
Black people who are military veterans	<input type="checkbox"/>	<input type="checkbox"/>
OR		
Any EME	<input type="checkbox"/>	<input type="checkbox"/>
Any QSE	<input type="checkbox"/>	<input type="checkbox"/>

**8. DECLARATION WITH REGARD TO COMPANY/FIRM**

8.1 Name of company/firm:.....

8.2 VAT registration number:.....

8.3 Company registration number:.....

8.4 TYPE OF COMPANY/ FIRM

- Partnership/Joint Venture / Consortium
- One person business/sole propriety
- Close corporation
- Company
- (Pty) Limited

[TICK APPLICABLE BOX]

8.5 DESCRIBE PRINCIPAL BUSINESS ACTIVITIES

.....  
.....  
.....

8.6 COMPANY CLASSIFICATION

- Manufacturer
- Supplier
- Professional Supplier/Service provider
- Other Suppliers/Service providers, e.g. transporter, etc.

[TICK APPLICABLE BOX]

8.7 Total number of years the company/firm has been in business:.....

8.8 I/we, the undersigned, who is / are duly authorised to do so on behalf of the company/firm, certify that the points claimed, based on the B-BBE status level of contribution indicated in paragraphs 1.4 and 6.1 of the foregoing certificate, qualifies the company/ firm for the preference(s) shown and I / we acknowledge that:

- i) The information furnished is true and correct;
- ii) The preference points claimed are in accordance with the General Conditions as indicated in paragraph 1 of this form;
- iii) In the event of a contract being awarded as a result of points claimed as shown in paragraph 1.4 and 6.1, the contractor may be required to furnish documentary proof to the satisfaction of the purchaser that the claims are correct;
- iv) If a bidder submitted false information regarding its B-BBEE status level of contributor,, which will affect or has affected the evaluation of a bid, or where a bidder has failed to declare any subcontracting arrangements or any of the conditions of contract have not been fulfilled, the purchaser may, in addition to any other remedy it may have
  - (a) disqualify the person from the bidding process;
  - (b) recover costs, losses or damages it has incurred or suffered as a result of that person's conduct;
  - (c) cancel the contract and claim any damages which it has suffered as a result of having to make less favourable arrangements due to such cancellation;
  - (d) if the successful bidder subcontracted a portion of the bid to another person without disclosing it, Transnet reserves the right to penalise the bidder up to 10 percent of the value of the contract;
  - (e) recommend that the bidder or contractor, its shareholders and directors, or only the shareholders and directors who acted on a fraudulent basis, be restricted by the National Treasury from obtaining business from any organ of state for a period not



exceeding 10 years, after the audi alteram partem (hear the other side) rule has been applied; and

- (f) forward the matter for criminal prosecution.

<p>WITNESSES</p> <p>1. ....</p> <p>2. ....</p>
--

<p>.....</p> <p>SIGNATURE(S) OF BIDDERS(S)</p> <p>DATE: .....</p>
---

**SBD4**

## **BIDDER'S DISCLOSURE**

### **1. PURPOSE OF THE FORM**

Any person (natural or juristic) may make an offer or offers in terms of this invitation to bid. In line with the principles of transparency, accountability, impartiality, and ethics as enshrined in the Constitution of the Republic of South Africa and further expressed in various pieces of legislation, it is required for the bidder to make this declaration in respect of the details required hereunder.

Where a person/s are listed in the Register for Tender Defaulters and / or the List of Restricted Suppliers, that person will automatically be disqualified from the bid process.

### **2. Bidder's declaration**

2.1 Is the bidder, or any of its directors / trustees / shareholders / members / partners or any person having a controlling interest<sup>2</sup> in the enterprise, employed by the state? **YES/NO**

2.1.1 If so, furnish particulars of the names, individual identity numbers, and, if applicable, state employee numbers of sole proprietor/ directors / trustees / shareholders / members/ partners or any person having a controlling interest in the enterprise, in table below.

<b>Full Name</b>	<b>Identity Number</b>	<b>Name of institution</b>	<b>State</b>

2.2 Do you, or any person connected with the bidder, have a relationship with any person who is employed by the procuring institution? **YES/NO**

<sup>2</sup> the power, by one person or a group of persons holding the majority of the equity of an enterprise, alternatively, the person/s having the deciding vote or power to influence or to direct the course and decisions of the enterprise.



2.2.1 If so, furnish particulars:

.....  
.....

2.3 Does the bidder or any of its directors / trustees / shareholders / members / partners or any person having a controlling interest in the enterprise have any interest in any other related enterprise whether or not they are bidding for this contract?  
**YES/NO**

2.3.1 If so, furnish particulars:

.....  
.....

### 3 DECLARATION

I, \_\_\_\_\_ the \_\_\_\_\_ undersigned,  
(name)..... in submitting  
the accompanying bid, do hereby make the following statements that I certify to  
be true and complete in every respect:

- 3.1 I have read and I understand the contents of this disclosure;
- 3.2 I understand that the accompanying bid will be disqualified if this disclosure is found not to be true and complete in every respect;
- 3.3 The bidder has arrived at the accompanying bid independently from, and without consultation, communication, agreement or arrangement with any competitor. However, communication between partners in a joint venture or consortium<sup>3</sup> will not be construed as collusive bidding.
- 3.4 In addition, there have been no consultations, communications, agreements or arrangements with any competitor regarding the quality, quantity, specifications, prices, including methods, factors or formulas used to calculate prices, market allocation, the intention or decision to submit or not to submit the bid, bidding with the intention not to win the bid and conditions or delivery particulars of the products or services to which this bid invitation relates.
- 3.4 The terms of the accompanying bid have not been, and will not be, disclosed by the bidder, directly or indirectly, to any competitor, prior to the date and time of the official bid opening or of the awarding of the contract.
- 3.5 There have been no consultations, communications, agreements or arrangements made by the bidder with any official of the procuring institution in relation to this procurement process prior to and during the bidding process except to provide clarification on the bid submitted where so required by the institution; and the bidder was not involved in the drafting of the specifications or terms of reference for this bid.

---

<sup>3</sup> Joint venture or Consortium means an association of persons for the purpose of combining their expertise, property, capital, efforts, skill and knowledge in an activity for the execution of a contract.

- 3.6 I am aware that, in addition and without prejudice to any other remedy provided to combat any restrictive practices related to bids and contracts, bids that are suspicious will be reported to the Competition Commission for investigation and possible imposition of administrative penalties in terms of section 59 of the Competition Act No 89 of 1998 and or may be reported to the National Prosecuting Authority (NPA) for criminal investigation and or may be restricted from conducting business with the public sector for a period not exceeding ten (10) years in terms of the Prevention and Combating of Corrupt Activities Act No 12 of 2004 or any other applicable legislation.

I CERTIFY THAT THE INFORMATION FURNISHED IN PARAGRAPHS 1, 2 and 3 ABOVE IS CORRECT.

I ACCEPT THAT THE STATE MAY REJECT THE BID OR ACT AGAINST ME IN TERMS OF PARAGRAPH 6 OF PFMA SCM INSTRUCTION 03 OF 2021/22 ON PREVENTING AND COMBATING ABUSE IN THE SUPPLY CHAIN MANAGEMENT SYSTEM SHOULD THIS DECLARATION PROVE TO BE FALSE.

..... Signature	..... Date
..... Position	..... Name of bidder

TRANSNET PORT TERMINALS

TENDER NUMBER: iCLM EL 725/TPT

DESCRIPTION OF THE WORKS: THE REFURBISHMENT OF THE GRAIN ELEVATOR SUBSTATIONS AT THE EAST LONDON MULTI PURPOSE TERMINAL FOR TRANSNET SOC LTD (REG NO. 1990/000900/30) OPERATING AS TRANSNET PORT TERMINALS (HEREINAFTER REFERRED AS "TPT") FOR THE DURATION OF 12 MONTHS

---

## **T2.2-16 NON-DISCLOSURE AGREEMENT**



**Note to tenderers: This Non-Disclosure Agreement is to be completed and signed by an authorised signatory:**

**THIS AGREEMENT** is made effective as of ..... day of ..... 20..... by and between:

**TRANSNET SOC LTD**

(Registration No. 1990/000900/30), a company incorporated and existing under the laws of South Africa, having its principal place of business at Transnet Corporate Centre 138 Eloff Street , Braamfontein , Johannesburg 2000

**and**

.....

(Registration No. ....), a private company incorporated and existing under the laws of South Africa having its principal place of business at

.....

.....

**WHEREAS**

Transnet and the Company wish to exchange Information [as defined below] and it is envisaged that each party may from time to time receive Information relating to the other in respect thereof. In consideration of each party making available to the other such Information, the parties jointly agree that any dealings between them shall be subject to the terms and conditions of this Agreement which themselves will be subject to the parameters of the Tender Document.

**IT IS HEREBY AGREED**

**1. INTERPRETATION**

In this Agreement:

- 1.1 **Agents** mean directors, officers, employees, agents, professional advisers, contractors or sub-contractors, or any Group member;
- 1.2 **Bid or Bid Document** (hereinafter Tender) means Transnet’s Request for Information [**RFI**] Request for Proposal [**RFP**] or Request for Quotation [**RFQ**], as the case may be;
- 1.3 **Confidential Information** means any information or other data relating to one party [the **Disclosing Party**] and/or the business carried on or proposed or intended to be carried on by that party and which is made available for the purposes of the Bid to the other party [the **Receiving Party**] or its Agents by the Disclosing Party or its Agents or recorded in agreed minutes following oral disclosure and any other information otherwise made available by the Disclosing Party or its Agents to the Receiving Party or its Agents, whether before, on or after the date of this Agreement, and whether in writing or otherwise, including any information, analysis or specifications derived from, containing or reflecting such information but excluding information which:

- 1.3.1 is publicly available at the time of its disclosure or becomes publicly available [other than as a result of disclosure by the Receiving Party or any of its Agents contrary to the terms of this Agreement]; or
- 1.3.2 was lawfully in the possession of the Receiving Party or its Agents [as can be demonstrated by its written records or other reasonable evidence] free of any restriction as to its use or disclosure prior to its being so disclosed; or
- 1.3.3 following such disclosure, becomes available to the Receiving Party or its Agents [as can be demonstrated by its written records or other reasonable evidence] from a source other than the Disclosing Party or its Agents, which source is not bound by any duty of confidentiality owed, directly or indirectly, to the Disclosing Party in relation to such information;
- 1.4 **Group** means any subsidiary, any holding company and any subsidiary of any holding company of either party; and
- 1.5 **Information** means all information in whatever form including, without limitation, any information relating to systems, operations, plans, intentions, market opportunities, know-how, trade secrets and business affairs whether in writing, conveyed orally or by machine-readable medium.

## 2. CONFIDENTIAL INFORMATION

- 2.1 All Confidential Information given by one party to this Agreement [the **Disclosing Party**] to the other party [the **Receiving Party**] will be treated by the Receiving Party as secret and confidential and will not, without the Disclosing Party's written consent, directly or indirectly communicate or disclose [whether in writing or orally or in any other manner] Confidential Information to any other person other than in accordance with the terms of this Agreement.
- 2.2 The Receiving Party will only use the Confidential Information for the sole purpose of technical and commercial discussions between the parties in relation to the Tender or for the subsequent performance of any contract between the parties in relation to the Tender.
- 2.3 Notwithstanding clause 2.1 above, the Receiving Party may disclose Confidential Information:
- 2.3.1 to those of its Agents who strictly need to know the Confidential Information for the sole purpose set out in clause 2.2 above, provided that the Receiving Party shall ensure that such Agents are made aware prior to the disclosure of any part of the Confidential Information that the same is confidential and that they owe a duty of confidence to the Disclosing Party. The Receiving Party shall at all times remain liable for any actions of such Agents that would constitute a breach of this Agreement; or
- 2.3.2 to the extent required by law or the rules of any applicable regulatory authority, subject to clause 2.4 below.
- 2.4 In the event that the Receiving Party is required to disclose any Confidential Information in accordance with clause 2.3.2 above, it shall promptly notify the Disclosing Party and cooperate with the Disclosing Party regarding the form, nature, content and purpose of such disclosure or any action which the Disclosing Party may reasonably take to challenge the validity of such requirement.

- 2.5 In the event that any Confidential Information shall be copied, disclosed or used otherwise than as permitted under this Agreement then, upon becoming aware of the same, without prejudice to any rights or remedies of the Disclosing Party, the Receiving Party shall as soon as practicable notify the Disclosing Party of such event and if requested take such steps [including the institution of legal proceedings] as shall be necessary to remedy [if capable of remedy] the default and/or to prevent further unauthorised copying, disclosure or use.
- 2.6 All Confidential Information shall remain the property of the Disclosing Party and its disclosure shall not confer on the Receiving Party any rights, including intellectual property rights over the Confidential Information whatsoever, beyond those contained in this Agreement.

### **3. RECORDS AND RETURN OF INFORMATION**

- 3.1 The Receiving Party agrees to ensure proper and secure storage of all Information and any copies thereof.
- 3.2 The Receiving Party shall keep a written record, to be supplied to the Disclosing Party upon request, of the Confidential Information provided and any copies made thereof and, so far as is reasonably practicable, of the location of such Confidential Information and any copies thereof.
- 3.3 The Company shall, within 7 [seven] days of receipt of a written demand from Transnet:
- 3.3.1 return all written Confidential Information [including all copies]; and
- 3.3.2 expunge or destroy any Confidential Information from any computer, word processor or other device whatsoever into which it was copied, read or programmed by the Company or on its behalf.
- 3.4 The Company shall on request supply a certificate signed by a director as to its full compliance with the requirements of clause 3.3.2 above.

### **4. ANNOUNCEMENTS**

- 4.1 Neither party will make or permit to be made any announcement or disclosure of its prospective interest in the Tender without the prior written consent of the other party.
- 4.2 Neither party shall make use of the other party's name or any information acquired through its dealings with the other party for publicity or marketing purposes without the prior written consent of the other party.

### **5. DURATION**

The obligations of each party and its Agents under this Agreement shall survive the termination of any discussions or negotiations between the parties regarding the Tender and continue thereafter for a period of 5 [five] years.

### **6. PRINCIPAL**

Each party confirms that it is acting as principal and not as nominee, agent or broker for any other person and that it will be responsible for any costs incurred by it or its advisers in considering or pursuing the Tender and in complying with the terms of this Agreement.

**7. ADEQUACY OF DAMAGES**

Nothing contained in this Agreement shall be construed as prohibiting the Disclosing Party from pursuing any other remedies available to it, either at law or in equity, for any such threatened or actual breach of this Agreement, including specific performance, recovery of damages or otherwise.

**8. PRIVACY AND DATA PROTECTION**

8.1 The Receiving Party undertakes to comply with South Africa’s general privacy protection in terms Section 14 of the Bill of Rights in connection with this Tender and shall procure that its personnel shall observe the provisions of such Act [as applicable] or any amendments and re-enactments thereof and any regulations made pursuant thereto.

8.2 The Receiving Party warrants that it and its Agents have the appropriate technical and organisational measures in place against unauthorised or unlawful processing of data relating to the Tender and against accidental loss or destruction of, or damage to such data held or processed by them.

**9. GENERAL**

9.1 Neither party may assign the benefit of this Agreement, or any interest hereunder, except with the prior written consent of the other, save that Transnet may assign this Agreement at any time to any member of the Transnet Group.

9.2 No failure or delay in exercising any right, power or privilege under this Agreement will operate as a waiver of it, nor will any single or partial exercise of it preclude any further exercise or the exercise of any right, power or privilege under this Agreement or otherwise.

9.3 The provisions of this Agreement shall be severable in the event that any of its provisions are held by a court of competent jurisdiction or other applicable authority to be invalid, void or otherwise unenforceable, and the remaining provisions shall remain enforceable to the fullest extent permitted by law.

9.4 This Agreement may only be modified by a written agreement duly signed by persons authorised on behalf of each party.

9.5 Nothing in this Agreement shall constitute the creation of a partnership, joint venture or agency between the parties.

9.6 This Agreement will be governed by and construed in accordance with South African law and the parties irrevocably submit to the exclusive jurisdiction of the South African courts.

Signed	_____	Date	_____
Name	_____	Position	_____
Tenderer	_____		

## T2.2-17: RFP DECLARATION FORM

NAME OF COMPANY: \_\_\_\_\_

We \_\_\_\_\_ do hereby certify that:

1. Transnet has supplied and we have received appropriate tender offers to any/all questions (as applicable) which were submitted by ourselves for tender clarification purposes;
2. we have received all information we deemed necessary for the completion of this Tender;
3. at no stage have we received additional information relating to the subject matter of this tender from Transnet sources, other than information formally received from the designated Transnet contact(s) as nominated in the tender documents;
4. we are satisfied, insofar as our company is concerned, that the processes and procedures adopted by Transnet in issuing this tender and the requirements requested from tenderers in responding to this tender have been conducted in a fair and transparent manner; and
5. furthermore, we acknowledge that a direct relationship exists between a family member and/or an owner / member / director / partner / shareholder (unlisted companies) of our company and an employee or board member of the Transnet Group as indicated below:

*[Respondent to indicate if this section is not applicable]*

FULL NAME OF OWNER/MEMBER/DIRECTOR/

PARTNER/SHAREHOLDER:

ADDRESS:

---

---

---

Indicate nature of relationship with Transnet:

---

---

---

---

*[Failure to furnish complete and accurate information in this regard may lead to the disqualification of your response and may preclude a Respondent from doing future business with Transnet]*

We declare, to the extent that we are aware or become aware of any relationship between ourselves and Transnet (other than any existing and appropriate business relationship with Transnet) which could unfairly advantage our company in the forthcoming adjudication process, we shall notify Transnet immediately in writing of such circumstances.

6. We accept that any dispute pertaining to this tender will be resolved through the Ombudsman process and will be subject to the Terms of Reference of the Ombudsman. The Ombudsman process must first be exhausted before judicial review of a decision is sought. (Refer "Important Notice to respondents" below).
7. We further accept that Transnet reserves the right to reverse a tender award or decision based on the recommendations of the Ombudsman without having to follow a formal court process to have such award or decision set aside.
8. We have acquainted ourselves and agree with the content of T2.2-20 "Service Provider Integrity Pact".

For and on behalf of ..... duly authorised thereto
Name:
Signature:
Date:

**IMPORTANT NOTICE TO TENDERERS**

- Transnet has appointed a Procurement Ombudsman to investigate any material complaint in respect of tenders exceeding R5,000,000.00 (five million S.A. Rand) in value. Should a Tenderer have any material concern regarding an tender process which meets this value threshold, a complaint may be lodged with Transnet's Procurement Ombudsman for further investigation.
- It is incumbent on the Tenderer to familiarise himself/herself with the Terms of Reference for the Transnet Procurement Ombudsman, details of which are available for review at Transnet's website [www.transnet.net](http://www.transnet.net).

- An official complaint form may be downloaded from this website and submitted, together with any supporting documentation, within the prescribed period, to [procurement.ombud@transnet.net](mailto:procurement.ombud@transnet.net)
- For transactions below the R5,000,000.00 (five million S.A. Rand) threshold, a complaint may be lodged with the Chief Procurement Officer of the relevant Transnet Operating Division.
- All Tenderers should note that a complaint must be made in good faith. If a complaint is made in bad faith, Transnet reserves the right to place such a tenderer on its List of Excluded Bidders.

## T2.2-18: REQUEST FOR PROPOSAL – BREACH OF LAW

NAME OF COMPANY: \_\_\_\_\_

I / We \_\_\_\_\_ do hereby certify that ***I/we have/have not been*** found guilty during the preceding 5 (five) years of a serious breach of law, including but not limited to a breach of the Competition Act, 89 of 1998, by a court of law, tribunal or other administrative body. The type of breach that the Tenderer is required to disclose excludes relatively minor offences or misdemeanours, e.g. traffic offences.

*Where found guilty of such a serious breach, please disclose:*

NATURE OF BREACH:

---

---

---

DATE OF BREACH:

---

Furthermore, I/we acknowledge that Transnet SOC Ltd reserves the right to exclude any Tenderer from the tendering process, should that person or company have been found guilty of a serious breach of law, tribunal or regulatory obligation.

Signed on this \_\_\_\_\_ day of \_\_\_\_\_ 20\_\_\_\_

---

SIGNATURE OF TENDER

## **T2.2-19 Certificate of Acquaintance with Tender Documents**

NAME OF TENDERING ENTITY:

---

1. By signing this certificate I/we acknowledge that I/we have made myself/ourselves thoroughly familiar with, and agree with all the conditions governing this RFP. This includes those terms and conditions of the Contract, the Supplier Integrity Pact, Non-Disclosure Agreement etc. contained in any printed form stated to form part of the documents thereof, but not limited to those listed in this clause.
2. I/we furthermore agree that Transnet SOC Ltd shall recognise no claim from me/us for relief based on an allegation that I/we overlooked any tender/contract condition or failed to take it into account for the purpose of calculating my/our offered prices or otherwise.
3. I/we understand that the accompanying Tender will be disqualified if this Certificate is found not to be true and complete in every respect.
4. For the purposes of this Certificate and the accompanying Tender, I/we understand that the word "competitor" shall include any individual or organisation, other than the Tenderer, whether or not affiliated with the Tenderer, who:
  - a) has been requested to submit a Tender in response to this Tender invitation;
  - b) could potentially submit a Tender in response to this Tender invitation, based on their qualifications, abilities or experience; and
  - c) provides the same Services as the Tenderer and/or is in the same line of business as the Tenderer
5. The Tenderer has arrived at the accompanying Tender independently from, and without consultation, communication, agreement or arrangement with any competitor. However communication between partners in a joint venture or consortium will not be construed as collusive Tendering.
6. In particular, without limiting the generality of paragraph 5 above, there has been no consultation, communication, agreement or arrangement with any competitor regarding:

- 
- a) prices;
  - b) geographical area where Services will be rendered [market allocation]
  - c) methods, factors or formulas used to calculate prices;
  - d) the intention or decision to submit or not to submit, a Tender;
  - e) the submission of a tender which does not meet the specifications and conditions of the tender; or
  - f) Tendering with the intention not winning the tender.
7. In addition, there have been no consultations, communications, agreements or arrangements with any competitor regarding the quality, quantity, specifications and conditions or delivery particulars of the Services to which this tender relates.
8. The terms of the accompanying tender have not been, and will not be, disclosed by the Tenderer, directly or indirectly, to any competitor, prior to the date and time of the official tender opening or of the awarding of the contract.
9. I/We am/are aware that, in addition and without prejudice to any other remedy provided to combat any restrictive practices related to tenders and contracts, tenders that are suspicious will be reported to the Competition Commission for investigation and possible imposition of administrative penalties in terms of section 59 of the Competition Act No 89 of 1998 and/or may be reported to the National Prosecuting Authority [NPA] for criminal investigation. In addition, Tenderers that submit suspicious tenders may be restricted from conducting business with the public sector for a period not exceeding 10 [ten] years in terms of the Prevention and Combating of Corrupt Activities Act No 12 of 2004 or any other applicable legislation.

Signed on this \_\_\_\_\_ day of \_\_\_\_\_ 20\_\_\_\_

---

SIGNATURE OF TENDERER

## **T2.2-20 Service Provider Integrity Pact**

**Important Note: All potential tenderers must read this document and certify in the RFP Declaration Form that that have acquainted themselves with, and agree with the content.**

**The contract with the successful tenderer will automatically incorporate this Integrity Pact and shall be deemed as part of the final concluded contract.**

### **INTEGRITY PACT**

Between

#### **TRANSNET SOC LTD**

Registration Number: 1990/000900/30

("Transnet")

and

The Contractor (hereinafter referred to as the "Tenderer/Service Providers/Contractor")

## **PREAMBLE**

Transnet values full compliance with all relevant laws and regulations, ethical standards and the principles of economical use of resources, fairness and transparency in its relations with its Tenderers/Service Providers/Contractors.

In order to achieve these goals, Transnet and the Tenderer/Service Provider/Contractor hereby enter into this agreement hereinafter referred to as the "Integrity Pact" which will form part of the Tenderer's/Service Provider's/Contractor's application for registration with Transnet as a vendor.

The general purpose of this Integrity Pact is to agree on avoiding all forms of dishonesty, fraud and corruption by following a system that is fair, transparent and free from any undue influence prior to, during and subsequent to the currency of any procurement and/or reverse logistics event and any further contract to be entered into between the Parties, relating to such event.

All Tenderers/Service Providers/Contractor's will be required to sign and comply with undertakings contained in this Integrity Pact, should they want to be registered as a Transnet vendor.

## **1 OBJECTIVES**

- 1.1 Transnet and the Tenderer/Service Provider/Contractor agree to enter into this Integrity Pact, to avoid all forms of dishonesty, fraud and corruption including practices that are anti-competitive in nature, negotiations made in bad faith and under-pricing by following a system that is fair, transparent and free from any influence/unprejudiced dealings prior to, during and subsequent to the currency of the contract to be entered into with a view to:
  - a) Enable Transnet to obtain the desired contract at a reasonable and competitive price in conformity to the defined specifications of the works, goods and services; and
  - b) Enable Tenderers/Service Providers/Contractors to abstain from bribing or participating in any corrupt practice in order to secure the contract.

## **2 COMMITMENTS OF TRANSNET**

Transnet commits to take all measures necessary to prevent dishonesty, fraud and corruption and to observe the following principles:

- 2.1 Transnet hereby undertakes that no employee of Transnet connected directly or indirectly with the sourcing event and ensuing contract, will demand, take a promise for or accept directly or through intermediaries any bribe, consideration, gift, reward, favour or any material or immaterial benefit or any other advantage

from the Tenderer, either for themselves or for any person, organisation or third party related to the contract in exchange for an advantage in the tendering process, Tender evaluation, contracting or implementation process related to any contract.

- 2.2 Transnet will, during the registration and tendering process treat all Tenderers/ Service Providers/Contractor with equity, transparency and fairness. Transnet will in particular, before and during the registration process, provide to all Tenderers/ Service Providers/Contractors the same information and will not provide to any Tenderers/Service Providers/Contractors confidential/additional information through which the Tenderers/Service Providers/Contractors could obtain an advantage in relation to any tendering process.
- 2.3 Transnet further confirms that its employees will not favour any prospective Tenderers/Service Providers/Contractors in any form that could afford an undue advantage to a particular Tenderer during the tendering stage, and will further treat all Tenderers/Service Providers/Contractors participating in the tendering process in a fair manner.
- 2.4 Transnet will exclude from the tender process such employees who have any personal interest in the Tenderers/Service Providers/Contractors participating in the tendering process.

### **3 OBLIGATIONS OF THE TENDERER / SERVICE PROVIDER**

- 3.1 Transnet has a '**Zero Gifts**' Policy. No employee is allowed to accept gifts, favours or benefits.
  - a) Transnet officials and employees **shall not** solicit, give or accept, or from agreeing to solicit, give, accept or receive directly or indirectly, any gift, gratuity, favour, entertainment, loan, or anything of monetary value, from any person or juridical entities in the course of official duties or in connection with any operation being managed by, or any transaction which may be affected by the functions of their office.
  - b) Transnet officials and employees **shall not** solicit or accept gifts of any kind, from vendors, suppliers, customers, potential employees, potential vendors, and suppliers, or any other individual or organisation irrespective of the value.
  - c) Under **no circumstances** should gifts, business courtesies or hospitality packages be accepted from or given to prospective suppliers participating in a tender process at the respective employee's Operating Division, regardless of retail value.

- d) Gratuities, bribes or kickbacks of any kind must never be solicited, accepted or offered, either directly or indirectly. This includes money, loans, equity, special privileges, personal favours, benefit or services. Such favours will be considered to constitute corruption.
- 3.2 The Tenderer/Service Provider/Contractor commits itself to take all measures necessary to prevent corrupt practices, unfair means and illegal activities during any stage of its Tender or during any ensuing contract stage in order to secure the contract or in furtherance to secure it and in particular the Tenderer/Service Provider/Contractor commits to the following:
- a) The Tenderer/Service Provider/Contractor will not, directly or through any other person or firm, offer, promise or give to Transnet or to any of Transnet's employees involved in the tendering process or to any third person any material or other benefit or payment, in order to obtain in exchange an advantage during the tendering process; and
- b) The Tenderer/Service Provider/Contractor will not offer, directly or through intermediaries, any bribe, gift, consideration, reward, favour, any material or immaterial benefit or other advantage, commission, fees, brokerage or inducement to any employee of Transnet, connected directly or indirectly with the tendering process, or to any person, organisation or third party related to the contract in exchange for any advantage in the tendering, evaluation, contracting and implementation of the contract.
- 3.3 The Tenderer/Service Provider/Contractor will not collude with other parties interested in the contract to preclude a competitive Tender price, impair the transparency, fairness and progress of the tendering process, Tender evaluation, contracting and implementation of the contract. The Tenderer / Service Provider further commits itself to delivering against all agreed upon conditions as stipulated within the contract.
- 3.4 The Tenderer/Service Provider/Contractor will not enter into any illegal or dishonest agreement or understanding, whether formal or informal with other Tenderers/Service Providers/Contractors. This applies in particular to certifications, submissions or non-submission of documents or actions that are restrictive or to introduce cartels into the tendering process.
- 3.5 The Tenderer/Service Provider/Contractor will not commit any criminal offence under the relevant anti-corruption laws of South Africa or any other country. Furthermore, the Tenderer/Service Provider/Contractor will not use for illegitimate purposes or for restrictive purposes or personal gain, or pass on to others, any information provided by Transnet as part of the business relationship,

regarding plans, technical proposals and business details, including information contained or transmitted electronically.

- 3.6 A Tenderer/Service Provider/Contractor of foreign origin shall disclose the name and address of its agents or representatives in South Africa, if any, involved directly or indirectly in the registration or tendering process. Similarly, the Tenderer / Service Provider / Contractor of South African nationality shall furnish the name and address of the foreign principals, if any, involved directly or indirectly in the registration or tendering process.
- 3.7 The Tenderer/Service Provider/Contractor will not misrepresent facts or furnish false or forged documents or information in order to influence the tendering process to the advantage of the Tenderer/Service Provider/Contractor or detriment of Transnet or other competitors.
- 3.8 Transnet may require the Tenderer/Service Provider/Contractor to furnish Transnet with a copy of its code of conduct. Such code of conduct must address the compliance programme for the implementation of the code of conduct and reject the use of bribes and other dishonest and unethical conduct.
- 3.9 The Tenderer/Service Provider/Contractor will not instigate third persons to commit offences outlined above or be an accessory to such offences.
- 3.10 The Tenderer/Service Provider/Contractor confirms that they will uphold the ten principles of the United Nations Global Compact (UNGC) in the fields of Human Rights, Labour, Anti-Corruption and the Environment when undertaking business with Transnet as follows:
  - a) Human Rights
    - Principle 1: Businesses should support and respect the protection of internationally proclaimed human rights; and
    - Principle 2: make sure that they are not complicit in human rights abuses.
  - b) Labour
    - Principle 3: Businesses should uphold the freedom of association and the effective recognition of the right to collective bargaining;
    - Principle 4: the elimination of all forms of forced and compulsory labour;
    - Principle 5: the effective abolition of child labour; and

- Principle 6: the elimination of discrimination in respect of employment and occupation.

c) Environment

- Principle 7: Businesses should support a precautionary approach to environmental challenges;
- Principle 8: undertake initiatives to promote greater environmental responsibility; and
- Principle 9: encourage the development and diffusion of environmentally friendly technologies.

d) Anti-Corruption

- Principle 10: Businesses should work against corruption in all its forms, including extortion and bribery.

#### **4 INDEPENDENT TENDERING**

4.1 For the purposes of that Certificate in relation to any submitted Tender, the Tenderer declares to fully understand that the word "competitor" shall include any individual or organisation, other than the Tenderer, whether or not affiliated with the Tenderer, who:

- a) has been requested to submit a Tender in response to this Tender invitation;
- b) could potentially submit a Tender in response to this Tender invitation, based on their qualifications, abilities or experience; and
- c) provides the same Goods and Services as the Tenderer and/or is in the same line of business as the Tenderer.

4.2 The Tenderer has arrived at his submitted Tender independently from, and without consultation, communication, agreement or arrangement with any competitor. However communication between partners in a joint venture or consortium will not be construed as collusive tendering.

4.3 In particular, without limiting the generality of paragraph 5 above, there has been no consultation, communication, agreement or arrangement with any competitor regarding:

- a) prices;
- b) geographical area where Goods or Services will be rendered [market allocation];
- c) methods, factors or formulas used to calculate prices;

- d) the intention or decision to submit or not to submit, a Tender;
  - e) the submission of a Tender which does not meet the specifications and conditions of the RFP; or
  - f) tendering with the intention of not winning the Tender.
- 4.4 In addition, there have been no consultations, communications, agreements or arrangements with any competitor regarding the quality, quantity, specifications and conditions or delivery particulars of the Goods or Services to which his/her tender relates.
- 4.5 The terms of the Tender as submitted have not been, and will not be, disclosed by the Tenderer, directly or indirectly, to any competitor, prior to the date and time of the official Tender opening or of the awarding of the contract.
- 4.6 Tenderers are aware that, in addition and without prejudice to any other remedy provided to combat any restrictive practices related to Tenders and contracts, Tenders that are suspicious will be reported to the Competition Commission for investigation and possible imposition of administrative penalties in terms of section 59 of the Competition Act No 89 of 1998 and/or may be reported to the National Prosecuting Authority [**NPA**] for criminal investigation and/or may be restricted from conducting business with the public sector for a period not exceeding 10 [ten] years in terms of the Prevention and Combating of Corrupt Activities Act No 12 of 2004 or any other applicable legislation.
- 4.7 Should the Tenderer find any terms or conditions stipulated in any of the relevant documents quoted in the Tender unacceptable, it should indicate which conditions are unacceptable and offer alternatives by written submission on its company letterhead, attached to its submitted Tender. Any such submission shall be subject to review by Transnet's Legal Counsel who shall determine whether the proposed alternative(s) are acceptable or otherwise, as the case may be.

## **5 DISQUALIFICATION FROM TENDERING PROCESS**

- 5.1 If the Tenderer/Service Provider/Contractor has committed a transgression through a violation of section 3 of this Integrity Pact or in any other form such as to put its reliability or credibility as a Tenderer/Service Provider/Contractor into question, Transnet may reject the Tenderer's / Service Provider's / Contractor's application from the registration or tendering process and remove the Tenderer/Service Provider/Contractor from its database, if already registered.

- 5.2 If the Tenderer/Service Provider/Contractor has committed a transgression through a violation of section 3, or any material violation, such as to put its reliability or credibility into question. Transnet may after following due procedures and at its own discretion also exclude the Tenderer/Service Provider/Contractor from future tendering processes. The imposition and duration of the exclusion will be determined by the severity of the transgression. The severity will be determined by the circumstances of the case, which will include amongst others the number of transgressions, the position of the transgressors within the company hierarchy of the Tenderer/Service Provider/Contractor and the amount of the damage. The exclusion will be imposed for up to a maximum of 10 (ten) years. However, Transnet reserves the right to impose a longer period of exclusion, depending on the gravity of the misconduct.
- 5.3 If the Tenderer/Service Provider/Contractor can prove that it has restored the damage caused by it and has installed a suitable corruption prevention system, or taken other remedial measures as the circumstances of the case may require, Transnet may at its own discretion revoke the exclusion or suspend the imposed penalty.

## **6 TRANSNET'S LIST OF EXCLUDED TENDERERS (BLACKLIST)**

- 6.1 The process of restriction is used to exclude a company/person from conducting future business with Transnet and other organs of state for a specified period. No Tender shall be awarded to a Tenderer whose name (or any of its members, directors, partners or trustees) appear on the Register of Tender Defaulters kept by National Treasury, or who have been placed on National Treasury's List of Restricted Suppliers. Transnet reserves the right to withdraw an award, or cancel a contract concluded with a Tenderer should it be established, at any time, that a tenderer has been restricted with National Treasury by another government institution.
- 6.2 All the stipulations on Transnet's restriction process as laid down in Transnet's Supply Chain Policy and Procurement Procedures Manual (CPM included) are included herein by way of reference. Below follows a condensed summary of this restriction procedure.
- 6.3 On completion of the restriction procedure, Transnet will submit the restricted entity's details (including the identity number of the individuals and registration number of the entity) to National Treasury for placement on National Treasury's Database of Restricted Suppliers for the specified period of exclusion. National Treasury will make the final decision on whether to restrict an entity from doing business with any organ of state for a period not exceeding 10 years and place

the entity concerned on the Database of Restricted Suppliers published on its official website.

6.4 The decision to restrict is based on one of the grounds for restriction. The standard of proof to commence the restriction process is whether a "*prima facie*" (i.e. on the face of it) case has been established.

6.5 Depending on the seriousness of the misconduct and the strategic importance of the Goods/Services, in addition to restricting a company/person from future business, Transnet may decide to terminate some or all existing contracts with the company/person as well.

6.6 A Service Provider or Contractor to Transnet may not subcontract any portion of the contract to a blacklisted company.

6.7 Grounds for blacklisting include: If any person/Enterprise which has submitted a Tender, concluded a contract, or, in the capacity of agent or subcontractor, has been associated with such Tender or contract:

a) Has, in bad faith, withdrawn such Tender after the advertised closing date and time for the receipt of Tenders;

b) has, after being notified of the acceptance of his Tender, failed or refused to sign a contract when called upon to do so in terms of any condition forming part of the Tender documents;

c) has carried out any contract resulting from such Tender in an unsatisfactory manner or has breached any condition of the contract;

d) has offered, promised or given a bribe in relation to the obtaining or execution of the contract;

e) has acted in a fraudulent or improper manner or in bad faith towards Transnet or any Government Department or towards any public body, Enterprise or person;

f) has made any incorrect statement in a certificate or other communication with regard to the Local Content of his Goods or his B-BBEE status and is unable to prove to the satisfaction of Transnet that:

(i) he made the statement in good faith honestly believing it to be correct;  
and

- (ii) before making such statement he took all reasonable steps to satisfy himself of its correctness;
  - g) caused Transnet damage, or to incur costs in order to meet the contractor's requirements and which could not be recovered from the contractor;
  - h) has litigated against Transnet in bad faith.
- 6.8 Grounds for blacklisting include a company/person recorded as being a company or person prohibited from doing business with the public sector on National Treasury's database of Restricted Service Providers or Register of Tender Defaulters.
- 6.9 Companies associated with the person/s guilty of misconduct (i.e. entities owned, controlled or managed by such persons), any companies subsequently formed by the person(s) guilty of the misconduct and/or an existing company where such person(s) acquires a controlling stake may be considered for blacklisting. The decision to extend the blacklist to associated companies will be at the sole discretion of Transnet.

## **7 PREVIOUS TRANSGRESSIONS**

- 7.1 The Tenderer/Service Provider/Contractor hereby declares that no previous transgressions resulting in a serious breach of any law, including but not limited to, corruption, fraud, theft, extortion and contraventions of the Competition Act 89 of 1998, which occurred in the last 5 (five) years with any other public sector undertaking, government department or private sector company that could justify its exclusion from its registration on the Tenderer's/Service Provider's/Contractor's database or any tendering process.
- 7.2 If it is found to be that the Tenderer/Service Provider/Contractor made an incorrect statement on this subject, the Tenderer/Service Provider/Contractor can be rejected from the registration process or removed from the Tenderer/Service Provider/Contractor database, if already registered, for such reason (refer to the Breach of Law Returnable Form contained in the document.)

## **8 SANCTIONS FOR VIOLATIONS**

- 8.1 Transnet shall also take all or any one of the following actions, wherever required to:
- a) Immediately exclude the Tenderer/Service Provider/Contractor from the tendering process or call off the pre-contract negotiations without giving any compensation

- the Tenderer/Service Provider/Contractor. However, the proceedings with the other Tenderer/ Service Provider/Contractor may continue;
- b) Immediately cancel the contract, if already awarded or signed, without giving any compensation to the Tenderer/Service Provider/Contractor;
  - c) Recover all sums already paid by Transnet;
  - d) Encash the advance bank guarantee and performance bond or warranty bond, if furnished by the Tenderer/Service Provider/Contractor, in order to recover the payments, already made by Transnet, along with interest;
  - e) Cancel all or any other contracts with the Tenderer/Service Provider/Contractor; and
  - f) Exclude the Tenderer/ Service Provider/Contractor from entering into any Tender with Transnet in future.

## 9 CONFLICTS OF INTEREST

9.1 A conflict of interest includes, inter alia, a situation in which:

- a) A Transnet employee has a personal financial interest in a tendering / supplying entity; and
- b) A Transnet employee has private interests or personal considerations or has an affiliation or a relationship which affects, or may affect, or may be perceived to affect his / her judgment in action in the best interest of Transnet, or could affect the employee's motivations for acting in a particular manner, or which could result in, or be perceived as favouritism or nepotism.

9.2 A Transnet employee uses his / her position, or privileges or information obtained while acting in the capacity as an employee for:

- a) Private gain or advancement; or
- b) The expectation of private gain, or advancement, or any other advantage accruing to the employee must be declared in a prescribed form.

Thus, conflicts of interest of any Tender committee member or any person involved in the sourcing process must be declared in a prescribed form.

9.3 If a Tenderer/Service Provider/Contractor has or becomes aware of a conflict of interest i.e. a family, business and / or social relationship between its owner(s)/ member(s)/director(s)/partner(s)/shareholder(s) and a Transnet employee/ member of Transnet's Board of Directors in respect of a Tender which will be considered for the Tender process, the Tenderer/Service Provider/ Contractor:

- a) must disclose the interest and its general nature, in the Request for Proposal ("RFX") declaration form; or
- b) must notify Transnet immediately in writing once the circumstances has arisen.

- 9.4 The Tenderer/Service Provider/Contractor shall not lend to or borrow any money from or enter into any monetary dealings or transactions, directly or indirectly, with any committee member or any person involved in the sourcing process, where this is done, Transnet shall be entitled forthwith to rescind the contract and all other contracts with the Tenderer/Service Provider/Contractor.

## 10 DISPUTE RESOLUTION

10.1 Transnet recognises that trust and good faith are pivotal to its relationship with its Tenderer / Service Provider / Contractor. When a dispute arises between Transnet and its Tenderer / Service Provider / Contractor, the parties should use their best endeavours to resolve the dispute in an amicable manner, whenever possible. Litigation in bad faith negates the principles of trust and good faith on which commercial relationships are based. Accordingly, following a blacklisting process as mentioned in paragraph 6 above, Transnet will not do business with a company that litigates against it in bad faith or is involved in any action that reflects bad faith on its part. Litigation in bad faith includes, but is not limited to the following instances:

- a) **Vexatious proceedings:** these are frivolous proceedings which have been instituted without proper grounds;
- b) **Perjury:** where a Tenderer / Service Provider / Contractor make a false statement either in giving evidence or on an affidavit;
- c) **Scurrilous allegations:** where a Tenderer / Service Provider / Contractor makes allegations regarding a senior Transnet employee which are without proper foundation, scandalous, abusive or defamatory; and
- d) **Abuse of court process:** when a Tenderer / Service Provider / Contractor abuses the court process in order to gain a competitive advantage during a Tender process.

## 11 GENERAL

11.1 This Integrity Pact is governed by and interpreted in accordance with the laws of the Republic of South Africa.

11.2 The actions stipulated in this Integrity Pact are without prejudice to any other legal action that may follow in accordance with the provisions of the law relating to any civil or criminal proceedings.

11.3 The validity of this Integrity Pact shall cover all the tendering processes and will be valid for an indefinite period unless cancelled by either Party.



11.4 Should one or several provisions of this Integrity Pact turn out to be invalid the remainder of this Integrity Pact remains valid.

11.5 Should a Tenderer/Service Provider/Contractor be confronted with dishonest, fraudulent or corruptive behaviour of one or more Transnet employees, Transnet expects its Tenderer/Service Provider/Contractor to report this behaviour directly to a senior Transnet official/employee or alternatively by using Transnet's "Tip-Off Anonymous" hotline number 0800 003 056, whereby your confidentiality is guaranteed.

The Parties hereby declare that each of them has read and understood the clauses of this Integrity Pact and shall abide by it. To the best of the Parties' knowledge and belief, the information provided in this Integrity Pact is true and correct.

---

I ..... duly authorised by the tendering entity, hereby certify that the tendering entity are **fully acquainted** with the contents of the Integrity Pact and further **agree to abide by it** in full.

Signature .....

Date .....

## **T2.2-21 : Supplier Code of Conduct**

Transnet SOC Limited aims to achieve the best value for money when buying or selling goods and obtaining services. This however must be done in an open and fair manner that supports and drives a competitive economy. Underpinning our process are several acts and policies that any supplier dealing with Transnet must understand and support. These are:

- The Transnet Procurement Policy – A guide for Tenderers.
- Section 217 of the Constitution - the five pillars of Public PSCM (Procurement and Supply Chain Management): fair, equitable, transparent, competitive and cost effective;
- The Public Finance Management Act (PFMA);
- The Broad Based Black Economic Empowerment Act (BBBEE)
- The Prevention and Combating of Corrupt Activities Act (PRECCA); and
- The Construction Industry Development Board Act (CIDB Act).

This code of conduct has been included in this contract to formally appraise Transnet Suppliers of Transnet's expectations regarding behaviour and conduct of its Suppliers.

### ***Prohibition of Bribes, Kickbacks, Unlawful Payments, and Other Corrupt Practices***

Transnet is in the process of transforming itself into a self-sustaining State Owned Enterprise, actively competing in the logistics industry. Our aim is to become a world class, profitable, logistics organisation. As such, our transformation is focused on adopting a performance culture and to adopt behaviours that will enable this transformation.

#### ***1. Transnet SOC Limited will not participate in corrupt practices. Therefore, it expects its suppliers to act in a similar manner.***

- Transnet and its employees will follow the laws of this country and keep accurate business records that reflect actual transactions with, and payments to, our suppliers.
- Employees must not accept or request money or anything of value, directly or indirectly, from suppliers.
- Employees may not receive anything that is calculated to:

- Illegally influence their judgement or conduct or to ensure the desired outcome of a sourcing activity;
- Win or retain business or to influence any act or decision of any person involved in sourcing decisions; or
- Gain an improper advantage.
- There may be times when a supplier is confronted with fraudulent or corrupt behaviour of Transnet employees. We expect our Suppliers to use our "Tip-offs Anonymous" Hot line to report these acts. (0800 003 056).

**2. *Transnet SOC Limited is firmly committed to the ideas of free and competitive enterprise.***

- Suppliers are expected to comply with all applicable laws and regulations regarding fair competition and antitrust practices.
- Transnet does not engage with non-value adding agents or representatives solely for the purpose of increasing BBBEE spend (fronting).

**3. *Transnet's relationship with suppliers requires us to clearly define requirements, to exchange information and share mutual benefits.***

- Generally, suppliers have their own business standards and regulations. Although Transnet cannot control the actions of our suppliers, we will not tolerate any illegal activities. These include, but are not limited to:
  - Misrepresentation of their product (origin of manufacture, specifications, intellectual property rights, etc);
  - Collusion;
  - Failure to disclose accurate information required during the sourcing activity (ownership, financial situation, BBBEE status, etc.);
  - Corrupt activities listed above; and
  - Harassment, intimidation or other aggressive actions towards Transnet employees.
- Suppliers must be evaluated and approved before any materials, components, products or services are purchased from them. Rigorous due diligence is conducted and the supplier is expected to participate in an honest and straight forward manner.

- Suppliers must record and report facts accurately, honestly and objectively. Financial records must be accurate in all material respects.

***Conflicts of Interest***

A conflict of interest arises when personal interests or activities influence (or appear to influence) the ability to act in the best interests of Transnet SOC Limited.

- Doing business with family members.
- Having a financial interest in another company in our industry

Where possible, contracts will be negotiated to include the above in the terms of such contracts. To the extent such terms are not included in contractual obligations and any of the above code is breached, then Transnet reserves its right to review doing business with these suppliers.

I, \_\_\_\_\_ of \_\_\_\_\_  
*(insert name of Director or as per Authority Resolution from Board of Directors)* *(insert name of Company)*

hereby acknowledge having read, understood and agree to the terms and conditions set out in the "Transnet Supplier Code of Conduct."

Signed this on day \_\_\_\_\_ at \_\_\_\_\_

\_\_\_\_\_  
Signature

## T2.2-22: Insurance provided by the *Contractor*

Clause 84.1 in NEC3 Engineering & Construction Contract (June 2005)(amended June 2006 and April 2013) requires that the *Contractor* provides the insurance stated in the insurance table except any insurance which the *Employer* is to provide as stated in the Contract Data.

Please provide the following details for insurance which the *Contractor* is still to provide. Notwithstanding this information all costs related to insurance are deemed included in the tenderer's rates and prices.

<b>Insurance against (See clause 84.2 of the ECC)</b>	<b>Name of Insurance Company</b>	<b>Cover</b>	<b>Premium</b>
Liability for death of or bodily injury to employees of the <i>Contractor</i> arising out of and in the course of their employment in connection with this contract			
Motor Vehicle Liability Insurance comprising (as a minimum) "Balance of Third Party" Risks including Passenger and Unauthorised Passenger Liability indemnity with a minimum indemnity limit of R5 000 000.			
Insurance in respect of loss of or damage to own property and equipment.			
(Other)			

## T2.2-23: Form of Intent to Provide a Performance Guarantee

It is hereby agreed by the Tenderer that a Performance Guarantee drafted **exactly** as provided in the tender documents will be provided by the Guarantor named below, which is a **bank or insurer registered in South Africa**:

Name of Guarantor  
(Bank/Insurer)

.....

Address

.....

The Performance Guarantee shall be provided within **2 (Two)** weeks after the Contract Date defined in the contract unless otherwise agreed to by the parties.

Signed

.....

Name

.....

Capacity

.....

On behalf of (name of tenderer)

.....

.....

Date

.....

### Confirmed by Guarantor's Authorised Representative

Signature(s)

.....

Name (print)

.....

Capacity

.....

On behalf of Guarantor  
(Bank/insurer)

.....

Date

.....



**T2.2-24: Three (3) years audited financial statements**

Attached to this schedule is the last three (3) years audited financial statements of the single tenderer/members of the Joint Venture.

NAME OF COMPANY/IES and INDEX OF ATTACHMENTS:

.....  
.....  
.....  
.....  
.....  
.....  
.....  
.....



TRANSNET PORT TERMINALS

TENDER NUMBER: iCLM EL 725/TPT

DESCRIPTION OF THE WORKS: THE REFURBISHMENT OF THE GRAIN ELEVATOR SUBSTATIONS AT THE EAST LONDON MULTI PURPOSE TERMINAL FOR TRANSNET SOC LTD (REG NO. 1990/000900/30) OPERATING AS TRANSNET PORT TERMINALS (HEREINAFTER REFERRED AS "TPT") FOR THE DURATION OF 12 MONTHS

## C1.1: Form of Offer & Acceptance

### Offer

The Employer, identified in the Acceptance signature block, has solicited offers to enter into a contract for the procurement of:

**THE REFURBISHMENT OF THE GRAIN ELEVATOR SUBSTATIONS AT THE EAST LONDON MULTI PURPOSE TERMINAL FOR TRANSNET SOC LTD (REG NO. 1990/000900/30) OPERATING AS TRANSNET PORT TERMINALS (HEREINAFTER REFERRED AS "TPT") FOR THE DURATION OF 12 MONTHS**

The tenderer, identified in the Offer signature block, has

<i>either</i>	examined the documents listed in the Tender Data and addenda thereto as listed in the Returnable Schedules, and by submitting this Offer has accepted the Conditions of Tender.
<i>or</i>	examined the draft contract as listed in the Acceptance section and agreed to provide this Offer.

By the representative of the tenderer, deemed to be duly authorised, signing this part of this Form of Offer and Acceptance the tenderer offers to perform all of the obligations and liabilities of the *Contractor* under the contract including compliance with all its terms and conditions according to their true intent and meaning for an amount to be determined in accordance with the *conditions of contract* identified in the Contract Data.

The offered total of the Prices exclusive of VAT is	<b>R</b>
Value Added Tax @ 15% is	<b>R</b>
The offered total of the Prices inclusive of VAT is	<b>R</b>
(in words)	

This Offer may be accepted by the Employer by signing the Acceptance part of this Form of Offer and Acceptance and returning one copy of this document including the Schedule of Deviations (if any) to the tenderer before the end of the period of validity stated in the Tender Data, or other period as agreed, whereupon the tenderer becomes the party named as the *Contractor* in the *conditions of contract* identified in the Contract Data.

Signature(s)

Name(s)

Capacity

**For the tenderer:**

(Insert name and address of organisation)

Name & signature of witness

Date

Tenderer's CIDB registration number:



TRANSNET PORT TERMINALS

TENDER NUMBER: iCLM EL 725/TPT

DESCRIPTION OF THE WORKS: THE REFURBISHMENT OF THE GRAIN ELEVATOR SUBSTATIONS AT THE EAST LONDON MULTI PURPOSE TERMINAL FOR TRANSNET SOC LTD (REG NO. 1990/000900/30) OPERATING AS TRANSNET PORT TERMINALS (HEREINAFTER REFERRED AS "TPT") FOR THE DURATION OF 12 MONTHS

## Acceptance

By signing this part of this Form of Offer and Acceptance, the *Employer* identified below accepts the tenderer's Offer. In consideration thereof, the *Employer* shall pay the *Contractor* the amount due in accordance with the *conditions of contract* identified in the Contract Data. Acceptance of the tenderer's Offer shall form an agreement between the *Employer* and the tenderer upon the terms and conditions contained in this agreement and in the contract that is the subject of this agreement.

The terms of the contract, are contained in:

- Part C1                    Agreements and Contract Data, (which includes this Form of Offer and Acceptance)
- Part C2                    Pricing Data
- Part C3                    Scope of Work: Works Information
- Part C4                    Site Information

and drawings and documents (or parts thereof), which may be incorporated by reference into the above listed Parts.

Deviations from and amendments to the documents listed in the Tender Data and any addenda thereto listed in the Returnable Schedules as well as any changes to the terms of the Offer agreed by the tenderer and the Employer during this process of offer and acceptance, are contained in the Schedule of Deviations attached to and forming part of this Form of Offer and Acceptance. No amendments to or deviations from said documents are valid unless contained in this Schedule.

The tenderer shall within two weeks of receiving a completed copy of this agreement, including the Schedule of Deviations (if any), contact the Employer's agent (whose details are given in the Contract Data) to arrange the delivery of any securities, bonds, guarantees, proof of insurance and any other documentation to be provided in terms of the *conditions of contract* identified in the Contract Data at, or just after, the date this agreement comes into effect. Failure to fulfil any of these obligations in accordance with those terms shall constitute a repudiation of this agreement.

Notwithstanding anything contained herein, this agreement comes into effect on the date when the tenderer receives one fully completed original copy of this document, including the Schedule of Deviations (if any).

Unless the tenderer (now *Contractor*) within five working days of the date of such receipt notifies the Employer in writing of any reason why he cannot accept the contents of this agreement, this agreement shall constitute a binding contract between the Parties.

Signature(s)

Name(s)

Capacity

**for the  
Employer**

Transnet SOC Ltd

*(Insert name and address of organisation)*

Name &  
signature of  
witness

Date



TRANSNET PORT TERMINALS

TENDER NUMBER: iCLM EL 725/TPT

DESCRIPTION OF THE WORKS: THE REFURBISHMENT OF THE GRAIN ELEVATOR SUBSTATIONS AT THE EAST LONDON MULTI PURPOSE TERMINAL FOR TRANSNET SOC LTD (REG NO. 1990/000900/30) OPERATING AS TRANSNET PORT TERMINALS (HEREINAFTER REFERRED AS "TPT") FOR THE DURATION OF 12 MONTHS

## Schedule of Deviations

Note:

1. To be completed by the Employer prior to award of contract. This part of the Offer & Acceptance would not be required if the contract has been developed by negotiation between the Parties and is not the result of a process of competitive tendering.
2. The extent of deviations from the tender documents issued by the Employer prior to the tender closing date is limited to those permitted in terms of the Conditions of Tender.
3. A tenderer's covering letter must not be included in the final contract document. Should any matter in such letter, which constitutes a deviation as aforesaid be the subject of agreement reached during the process of Offer and Acceptance, the outcome of such agreement shall be recorded here and the final draft of the contract documents shall be revised to incorporate the effect of it.

No.	Subject	Details
1		
2		
3		
4		
5		

By the duly authorised representatives signing this Schedule of Deviations below, the Employer and the tenderer agree to and accept this Schedule of Deviations as the only deviations from and amendments to the documents listed in the Tender Data and any addenda thereto listed in the Tender Schedules, as well as any confirmation, clarification or changes to the terms of the Offer agreed by the tenderer and the Employer during this process of Offer and Acceptance.

It is expressly agreed that no other matter whether in writing, oral communication or implied during the period between the issue of the tender documents and the receipt by the tenderer of a completed signed copy of this Form shall have any meaning or effect in the contract between the parties arising from this Agreement.

	<b>For the tenderer:</b>	<b>For the Employer</b>
Signature	.....	.....
Name	.....	.....
Capacity	.....	.....
On behalf of	<i>(Insert name and address of organisation)</i>	Transnet SOC Ltd
Name & signature of witness	.....	.....
Date	.....	.....

## C1.2 Contract Data

### Part one - Data provided by the *Employer*

Clause	Statement	Data
1	<b>General</b>	
	The <i>conditions of contract</i> are the core clauses and the clauses for main Option	<b>B: Priced contract with bill of quantities</b>
	dispute resolution Option	<b>W1: Dispute resolution procedure</b>
	and secondary Options	<b>X5: Sectional Completion</b> <b>X7: Delay damages</b> <b>X13: Performance Bond</b> <b>X16: Retention</b> <b>X18: Limitation of liability</b> <b>Z: Additional conditions of contract</b>
	of the NEC3 Engineering and Construction Contract June 2005 (amended June 2006 and April 2013)	
10.1	The <i>Employer</i> is:	<b>Transnet SOC Ltd</b> <b>(Registration No. 1990/000900/30)</b>
	Address	Registered address: <b>Carlton Centre</b> <b>150 Commissioner Street</b> <b>Johannesburg</b> <b>2001</b>
	Having elected its Contractual Address for the purposes of this contract as:	<b>Transnet Port Terminals</b> <b>202 Anton Lembede Street</b> <b>Durban</b> <b>4001</b>

---

TRANSNET PORT TERMINALS  
 TENDER NUMBER: iCLM EL 725/TPT  
 DESCRIPTION OF THE WORKS: THE REFURBISHMENT OF THE GRAIN ELEVATOR SUBSTATIONS AT THE EAST LONDON MULTI PURPOSE TERMINAL FOR TRANSNET SOC LTD (REG NO. 1990/000900/30) OPERATING AS TRANSNET PORT TERMINALS (HEREINAFTER REFERRED AS "TPT") FOR THE DURATION OF 12 MONTHS

10.1	The <i>Project Manager</i> is: (Name)	<b>Nowhi Hloma</b>
	Address	<b>Transnet Port Terminals Port of East London</b>
	Tel	
	e-mail	<b>nowhi.hloma@transnet.net</b>
10.1	The <i>Supervisor</i> is: (Name)	<b>Lonwabo Mkalipi</b>
	Address	<b>Transnet Port Terminals Port of East London</b>
	Tel No.	
	e-mail	<b>lonwabo.mkalipi@transnet.net</b>
11.2(13)	The <i>works</i> are	<b>The refurbishment of the grain elevator substations at the East London Multi-Purpose Terminal for Transnet SOC Ltd (Reg no. 1990/000900/30) operating as Transnet Port Terminals (hereinafter referred as "TPT") for the duration of 12 months</b>
11.2(14)	The following matters will be included in the Risk Register	<b>Failure to meet project timelines Commissioning delays Quality Risk Environmental risk Inclement adverse weather challenges Labour unrest Safety Waste Management</b>
11.2(15)	The <i>boundaries of the site</i> are	<b>As stated in Part C4.1. "Description of the Site and its surroundings"</b>
11.2(16)	The Site Information is in	<b>Part C4</b>
11.2(19)	The Works Information is in	<b>Part C3</b>
12.2	The <i>law of the contract</i> is the law of	<b>the Republic of South Africa subject to the jurisdiction of the Courts of South Africa.</b>
13.1	The <i>language of this contract</i> is	<b>English</b>
13.3	The <i>period for reply</i> is	<b>2 weeks</b>

TRANSNET PORT TERMINALS  
 TENDER NUMBER: iCLM EL 725/TPT  
 DESCRIPTION OF THE WORKS: THE REFURBISHMENT OF THE GRAIN ELEVATOR SUBSTATIONS AT THE EAST LONDON MULTI PURPOSE TERMINAL FOR TRANSNET SOC LTD (REG NO. 1990/000900/30) OPERATING AS TRANSNET PORT TERMINALS (HEREINAFTER REFERRED AS "TPT") FOR THE DURATION OF 12 MONTHS

---

**2**      **The *Contractor's* main responsibilities**      **No additional data is required for this section of the *conditions of contract*.**

---

**3**      **Time**

11.2(3)      The *completion date* for the whole of the *works* is      **12 Months**

---

11.2(9)	The <i>key dates</i> and the <i>conditions</i> to be met are:	<b><i>Condition to be met</i></b>	<b><i>key date</i></b>
		<b>1 Site Establishment</b>	<b>TBC</b>
		<b>2 Transportation of new Switchgear</b>	<b>TBC</b>
		<b>3 Dismantling of existing MV and LV switchgear and transportation.</b>	<b>TBC</b>
		<b>4 Supply, install and commissioning of new MV switchgear.</b>	<b>TBC</b>
		<b>5 Supply, install and commissioning of new LV switchgear.</b>	<b>TBC</b>
		<b>6 Supply, install and commissioning of new fire detection and suppression system.</b>	<b>TBC</b>
		<b>7 Supply, install and commissioning of the room climate control.</b>	<b>TBC</b>
		<b>8 Supply of the MV switchgear spares.</b>	<b>TBC</b>
		<b>9 Cable testing and repairs.</b>	<b>TBC</b>
		<b>10 Earthing and bonding system testing</b>	<b>TBC</b>
		<b>11 Building repairs</b>	<b>TBC</b>
		<b>12 Supply of data pack</b>	<b>TBC</b>
		<b>13 Other (Building Separation Of MV &amp; LV)</b>	<b>TBC</b>

TRANSNET PORT TERMINALS  
TENDER NUMBER: iCLM EL 725/TPT  
DESCRIPTION OF THE WORKS: THE REFURBISHMENT OF THE GRAIN ELEVATOR SUBSTATIONS AT THE EAST LONDON MULTI PURPOSE TERMINAL FOR TRANSNET SOC LTD (REG NO. 1990/000900/30) OPERATING AS TRANSNET PORT TERMINALS (HEREINAFTER REFERRED AS "TPT") FOR THE DURATION OF 12 MONTHS

30.1	The <i>access dates</i> are	<b>Part of the Site</b>	<b>Date</b>
		<b>1 Access to entire site</b>	<b>TBC</b>
31.1	The <i>Contractor</i> is to submit a first programme for acceptance within	<b>2 weeks of the Contract Date.</b>	
31.2	The <i>starting date</i> is	<b>TBA</b>	
32.2	The <i>Contractor</i> submits revised programmes at intervals no longer than	<b>2 weeks.</b>	
35.1	The <i>Employer</i> is not willing to take over the <i>works</i> before the Completion Date.		
<b>4</b>	<b>Testing and Defects</b>		
42.2	The <i>defects date</i> is	<b>52 (fifty-two) weeks after Completion of the whole of the <i>works</i>.</b>	
43.2	The <i>defect correction period</i> is	<b>2 weeks</b>	
<b>5</b>	<b>Payment</b>		
50.1	The <i>assessment interval</i> is	<b>25<sup>th</sup> (twenty fifth) day of each successive month.</b>	
51.1	The <i>currency of this contract</i> is the	<b>South African Rand.</b>	
51.2	The period within which payments are made is	<b>Payment will be effected on or before the last day of the month following the month during which a valid Tax Invoice and Statement were received.</b>	
51.4	The <i>interest rate</i> is	<b>the prime lending rate of Standard Bank of South Africa.</b>	
<b>6</b>	<b>Compensation events</b>		
60.1(13)	The <i>weather measurements</i> to be recorded for each calendar month are,	<b>the cumulative rainfall (mm)</b>	
		<b>the number of days with rainfall more than 10 mm</b>	
		<b>the number of days with wind speed exceeding 40 km/hr</b>	

The place where weather is to be recorded (on the Site ) is: **The *Contractor's* Site establishment area**

The *weather data* are the records of past *weather measurements* for each calendar month which were recorded at: **East London Weather Station**

and which are available from: **South African Weather Service 012 367 6023 or [info3@weathersa.co.za](mailto:info3@weathersa.co.za).**

<b>7</b>	<b>Title</b>	<b>No additional data is required for this section of the <i>conditions of contract</i>.</b>
<b>8</b>	<b>Risks and insurance</b>	
80.1	These are additional <i>Employer's</i> risks	<b>No additional risks are accepted by the Employer other than those which are provided for in this contract</b>
84.1	The <i>Employer</i> provides these insurances from the Insurance Table	
	1 Insurance against:	<b>Loss of or damage to the <i>works</i>, Plant and Materials is as stated in the Insurance policy for Contract Works/ Public Liability.</b>
	Cover / indemnity:	<b>to the extent as stated in the insurance policy for Contract Works / Public Liability</b>
	The deductibles are:	<b>as stated in the insurance policy for Contract Works / Public Liability</b>
	2 Insurance against:	<b>Loss of or damage to property (except the <i>works</i>, Plant and Materials &amp; Equipment) and liability for bodily injury to or death of a person (not an employee of the <i>Contractor</i>) arising out of or in connection with the performance of the Contract as stated in the insurance policy for Contract Works / Public Liability</b>

TRANSNET PORT TERMINALS  
 TENDER NUMBER: iCLM EL 725/TPT  
 DESCRIPTION OF THE WORKS: THE REFURBISHMENT OF THE GRAIN ELEVATOR SUBSTATIONS AT THE EAST LONDON MULTI PURPOSE TERMINAL FOR TRANSNET SOC LTD (REG NO. 1990/000900/30) OPERATING AS TRANSNET PORT TERMINALS (HEREINAFTER REFERRED AS "TPT") FOR THE DURATION OF 12 MONTHS

Cover / indemnity	<b>Is to the extent as stated in the insurance policy for Contract Works / Public Liability</b>
The deductibles are	<b>as stated in the insurance policy for Contract Works / Public Liability</b>
3 Insurance against:	<b>Loss of or damage to Equipment (Temporary Works only) as stated in the insurance policy for contract Works and Public Liability</b>
Cover / indemnity	<b>Is to the extent as stated in the insurance policy for Contract Works / Public Liability</b>
The deductibles are:	<b>As stated in the insurance policy for Contract Works / Public Liability</b>
4 Insurance against:	<b>Contract Works SASRIA insurance subject to the terms, exceptions and conditions of the SASRIA coupon</b>
Cover / indemnity	<b>Cover / indemnity is to the extent provided by the SASRIA coupon</b>
The deductibles are	<b>The deductibles are, in respect of each and every theft claim, 0,1% of the contract value subject to a minimum of R2,500 and a maximum of R25,000.</b>
Note:	<b>The deductibles for the insurance as stated above are listed in the document titled "Certificate of Insurance: Transnet (SOC) Limited Principal Controlled Insurance." Refer to Annexure AA</b>

84.1 The minimum limit of indemnity for insurance in respect of death of or bodily injury to employees of the *Contractor* arising out of and in the course of their employment in connection with this contract for any one event is **The *Contractor* must comply at a minimum with the provisions of the Compensation for Occupational Injuries and Diseases Act No. 130 of 1993 as amended.**

- 
- The *Contractor* provides these additional Insurances
- 1 **Where the contract requires that the design of any part of the *works* shall be provided by the *Contractor* the *Contractor* shall satisfy the *Employer* that professional indemnity insurance cover in connection therewith has been affected**
  - 2 **Where the contract involves manufacture, and/or fabrication of Plant & Materials, components or other goods to be incorporated into the *works* at premises other than the site, the *Contractor* shall satisfy the *Employer* that such plant & materials, components or other goods for incorporation in the *works* are adequately insured during manufacture and/or fabrication and transportation to the site.**
  - 3 **Should the *Employer* have an insurable interest in such items during manufacture, and/or fabrication, such interest shall be noted by endorsement to the *Contractor's* policies of insurance as well as those of any sub-contractor**
  - 4 **Motor Vehicle Liability Insurance comprising (as a minimum) "Balance of Third Party" Risks including Passenger and Unauthorised Passenger Liability indemnity with a minimum indemnity limit of R 5 000 000.**

**5 The insurance coverage referred to in 1, 2, 3, and 4 above shall be obtained from an insurer(s) in terms of an insurance policy approved by the *Employer*. The *Contractor* shall arrange with the insurer to submit to the *Project Manager* the original and the duplicate original of the policy or policies of insurance and the receipts for payment of current premiums, together with a certificate from the insurer or insurance broker concerned, confirming that the policy or policies provide the full coverage as required. The original policy will be returned to the *Contractor*.**

84.2 The minimum limit of indemnity for insurance in respect of loss of or damage to property (except the works, Plant, Materials and Equipment) and liability for bodily injury to or death of a person (not an employee of the *Contractor*) caused by activity in connection with this contract for any one event is

**Whatever the *Contractor* requires in addition to the amount of insurance taken out by the *Employer* for the same risk.**

84.2 The insurance against loss of or damage to the works, Plant and Materials as stated in the insurance policy for contract works and public liability selected from:

**Principal Controlled Insurance policy for Contract OR Project Specific Insurance for the contract**

**9 Termination** There is no additional Contract Data required for this section of the *conditions of contract*.

**10 Data for main Option clause**

**B Priced contract with Bill of Quantities** No additional data is required for this Option.

**11 Data for Option W1**

W1.1	The <i>Adjudicator</i> is	<b>Both parties will agree as and when a dispute arises. If the parties cannot reach an agreement on the <i>Adjudicator</i>, the Chairman of the Association of Arbitrators will appoint an <i>Adjudicator</i>.</b>
W1.2(3)	The <i>Adjudicator nominating body</i> is:  If no <i>Adjudicator nominating body</i> is entered, it is:	<b>The Chairman of the Association of Arbitrators (Southern Africa)</b>  <b>the Association of Arbitrators (Southern Africa)</b>
W1.4(2)	The <i>tribunal</i> is:	<b>Arbitration</b>
W1.4(5)	The <i>arbitration procedure</i> is	<b>The Rules for the Conduct of Arbitrations of the Association of Arbitrators (Southern Africa)</b>
	The place where arbitration is to be held is	<b>Durban, South Africa</b>
	The person or organisation who will choose an arbitrator - if the Parties cannot agree a choice or - if the arbitration procedure does not state who selects an arbitrator, is	<b>The Chairman of the Association of Arbitrators (Southern Africa)</b>

**12 Data for secondary Option clauses**

**X5 Sectional Completion**

X5.1	The <i>completion date</i> for each <i>section</i> of the <i>works</i> is:	<b><i>Section</i></b>	<b><i>Description</i></b>	<b><i>Completion date</i></b>
		<b>1</b>	<b>Substation 1</b>	<b>TBC</b>
		<b>2</b>	<b>Substation 2</b>	<b>TBC</b>

**X7 Delay damages**

X7.1	Delay damages for Completion of the whole of the <i>works</i> are	<b>0.1% of the total contract value per day limited to 10% of the total contract value</b>
------	---	--

<b>X13</b>	<b>Performance bond</b>	
X13.1	The amount of the performance bond is	<b>5% of the total of the Prices</b>
<b>X16</b>	<b>Retention</b>	
X16.1	The retention free amount is	<b>Nil</b>
	The retention percentage is	<b>10% on all payments certified.</b>
<b>X18</b>	<b>Limitation of liability</b>	
X18.1	The <i>Contractor's</i> liability to the <i>Employer</i> for indirect or consequential loss is limited to:	<b>An amount being equal to the loss or total contract value inclusive of VAT</b>
X18.2	For any one event, the <i>Contractor's</i> liability to the <i>Employer</i> for loss of or damage to the <i>Employer's</i> property is limited to:	<b>The deductible of the relevant insurance policy</b>
X18.3	The <i>Contractor's</i> liability for Defects due to his design which are not listed on the Defects Certificate is limited to:	<b>The cost of correcting the Defect</b>
X18.4	The <i>Contractor's</i> total liability to the <i>Employer</i> for all matters arising under or in connection with this contract, other than excluded matters, is limited to:	<b>The Total of the Prices</b>
X18.5	The <i>end of liability date</i> is	<b>A period being 12 (twelve) consecutive months after the completion by the Contractor of the whole of the works to the Employer in terms of the Contract</b>

TRANSNET PORT TERMINALS  
TENDER NUMBER: iCLM EL 725/TPT  
DESCRIPTION OF THE WORKS: THE REFURBISHMENT OF THE GRAIN ELEVATOR SUBSTATIONS AT THE EAST LONDON MULTI PURPOSE TERMINAL FOR TRANSNET SOC LTD (REG NO. 1990/000900/30) OPERATING AS TRANSNET PORT TERMINALS (HEREINAFTER REFERRED AS "TPT") FOR THE DURATION OF 12 MONTHS

---

**Z**            ***Additional conditions of contract are:***

---

**Z2**            **Additional clause relating to Performance Bonds and/or Guarantees**

**Z2.1**            **The Performance Guarantee under X13 above shall be an irrevocable, on-demand performance guarantee, to be issued exactly in the form of the Pro Forma documents provided for this purpose under C1.3 (Forms of Securities), in favour of the *Employer* by a financial institution reasonably acceptable to the *Employer*.**

---

**Z3 Additional clauses relating to Joint Venture**

**Z3.1 Insert the additional core clause 27.5**

**27.5. In the instance that the *Contractor* is a joint venture, the *Contractor* shall provide the *Employer* with a certified copy of its signed joint venture agreement, and in the instance that the joint venture is an 'Incorporated Joint Venture,' the Memorandum of Incorporation, within 4 (four) weeks of the Contract Date. The Joint Venture agreement shall contain but not be limited to the following:**

- **A brief description of the Contract and the Deliverables;**
- **The name, physical address, communications addresses and domicilium citandi et executandi of each of the constituents and of the Joint Venture;**
- **The constituent's interests;**
- **A schedule of the insurance policies, sureties, indemnities and guarantees which must be taken out by the Joint Venture and by the individual constituents;**
- **Details of an internal dispute resolution procedure;**
- **Written confirmation by all of the constituents:**
  - i. **of their joint and several liabilities to the *Employer* to Provide the Works;**
  - ii. **identification of the lead partner in the joint venture confirming the authority of the lead partner to bind the joint venture through the *Contractor's* representative;**

**iii. Identification of the roles and responsibilities of the constituents to provide the Works.**

- **Financial requirements for the Joint Venture:**

**iv. the working capital requirements for the Joint Venture and the extent to which and manner whereby this will be provided and/or guaranteed by the constituents from time to time;**

**v. the names of the auditors and others, if any, who will provide auditing and accounting services to the Joint Venture.**

**Z3.2**

**Insert additional core clause 27.6**

**27.6. The *Contractor* shall not alter its composition or legal status of the Joint Venture without the prior approval of the *Employer*.**

**Z4 Additional obligations in respect of Termination**

**Z4.1**

**The following will be included under core clause 91.1:**

**In the second main bullet, after the word 'partnership' add 'joint venture whether incorporate or otherwise (including any constituent of the joint venture)' and**

**Under the second main bullet, insert the following additional bullets after the last sub-bullet:**

- **commenced business rescue proceedings (R22)**
- **repudiated this Contract (R23)**

<b>Z4.2</b>	<b>Termination Table</b>	<b>The following will be included under core clause 90.2 Termination Table as follows:</b>
		<b>Amend "A reason other than R1 – R21" to "A reason other than R1 – R23"</b>
<b>Z4.3</b>		<b>Amend "R1 – R15 or R18" to "R1 – R15, R18, R22 or R23."</b>
<b>Z5</b>	<b>Right Reserved by the Employer to Conduct Vetting through SSA</b>	
<b>Z5.1</b>		<b>The Employer reserves the right to conduct vetting through State Security Agency (SSA) for security clearances of any Contractor who has access to National Key Points for the following without limitations:</b>
		<ol style="list-style-type: none"> <li><b>1. Confidential – this clearance is based on any information which may be used by malicious, opposing or hostile elements to harm the objectives and functions of an organ of state.</b></li> <li><b>2. Secret – clearance is based on any information which may be used by malicious, opposing or hostile elements to disrupt the objectives and functions of an organ of state.</b></li> <li><b>3. Top Secret – this clearance is based on information which may be used by malicious, opposing or hostile elements to neutralise the objectives and functions of an organ of state.</b></li> </ol>
<b>Z6</b>	<b>Additional Clause Relating to Collusion in the Construction Industry</b>	
<b>Z6.1</b>		<b>The contract award is made without prejudice to any rights the Employer may have to take appropriate action later with regard to any declared tender rigging including blacklisting.</b>

TRANSNET PORT TERMINALS  
 TENDER NUMBER: iCLM EL 725/TPT  
 DESCRIPTION OF THE WORKS: THE REFURBISHMENT OF THE GRAIN ELEVATOR SUBSTATIONS AT THE EAST LONDON MULTI PURPOSE TERMINAL FOR TRANSNET SOC LTD (REG NO. 1990/000900/30) OPERATING AS TRANSNET PORT TERMINALS (HEREINAFTER REFERRED AS "TPT") FOR THE DURATION OF 12 MONTHS

**Z7 Protection of Personal Information Act**

**Z7.1** The *Employer* and the *Contractor* are required to process information obtained for the duration of the Agreement in a manner that is aligned to the Protection of Personal Information Act.

**Z8 Assignment and Waiver**

**Z8.1** Neither the Employer nor the Contractor may, without the written consent of the other, assign the Contract or any part thereof or any obligation under the Contract or cede any right or benefit thereunder.

**Z8.2** No grant by the Contractor or the Employer to the other of any concession, waiver, condonation or allowance is, in respect of any specific event or circumstance other than that in respect of which the grant was made to constitute a waiver of the rights of the grantor in terms of the Contract or an estoppel of the grantor's right to enforce the provisions of the Contract.

**Z9 Anti-corruption, TPT Indemnity**

**Z9.1 Anti - Corruption**

**In the event that the Contractor is alleged to be, or found by any competent court or Tribunal to be involved in any corrupt, unlawful or illegal activities, or is being investigated for any alleged corrupt, unlawful or illegal activity in relation to Transnet or any other party with whom Contractor does business, or if Transnet learns that:**

- a. Improper payments are being or have been made or offered to Transnet officials or any other person by Contractor or those acting on behalf of Contractor with respect to the Services; or**
- b. *Contractor* or those acting on behalf of *Contractor* has accepted any payment or benefit, regardless of value, as an improper inducement to award, obtain or retain business or otherwise gain or grant an improper business advantage from or to any other person or entity.**

**Transnet reserves the right to terminate the aforementioned awarded contract, by giving immediate written notice to the effect that, all or any Agreements it may have with *Contractor* or any and all Awards made *Contractor* for breach of this clause.**

**Further in the event of such termination, Contractor shall not be entitled to any further payment, regardless of any activities undertaken or agreements with additional third parties entered into by Contractor prior to such termination; and further.**

**Contractor shall be liable to Transnet for any actual damages or remedies as provided either in the Agreements that are to be signed or in law.**

**Z9.2 Indemnity**

**1) Contractor irrevocably and unconditionally undertakes to indemnify and does hereby keep TPT indemnified and hold TPT harmless against, and, in respect of, all and any loss or damage incurred by itself or any other third- Party as a result of, arising out of or connected with any failure, act or omission or breach of this Agreement by Contractor or any of its employees, security officers, servants, agents , assigns, contractors or sub-contractors, or occurring during or as a result of the provision by the Contractor of the Security Service. Such absolute obligation of Contractor to indemnify TPT on a full indemnity basis against all claims shall including, but not be limited to:**

**a) liability in respect of any loss or damage to property, whether movable or immovable, belonging to third parties; or other**

**b) liability in respect of lost property belonging to third parties;**

**c) liability arising out of any unlawful act committed by or *Contractor* or its employees, security officers, servants, agents, contractors and sub-contractors during the process of rendering a Security Services; or at any other time when a claim**



TRANSNET PORT TERMINALS

TENDER NUMBER: iCLM EL 725/TPT

DESCRIPTION OF THE WORKS: THE REFURBISHMENT OF THE GRAIN ELEVATOR SUBSTATIONS AT THE EAST LONDON MULTI PURPOSE TERMINAL FOR TRANSNET SOC LTD (REG NO. 1990/000900/30) OPERATING AS TRANSNET PORT TERMINALS (HEREINAFTER REFERRED AS "TPT") FOR THE DURATION OF 12 MONTHS

---

**has been and could be made against the TPT arising out of the acts of or omissions of one or more of such persons;**

**d) liability in respect of the death, unlawful arrest, injury, illness or disease of any person, or entity should the damage, loss, unlawful arrest, death, injury, illness or disease referred to above be attributable to or arise out of the Security Services that are being or have been rendered by the Contractor, its agents, contractors, sub-contractors in terms of this Agreement.**

**2) Contractor shall at its own expense and with effect from the date of signature hereof, take reasonable precautions for the protection of life and or property that is in any way connected with in whole or any part of this agreement and shall hold TPT harmless against all claims for any loss, demands, proceedings, damages, costs, charges, expenses whatsoever, arising out of this agreement.**

**3) Contractor agrees that it shall intervene in any claim arising and to indemnify and hold TPT harmless from any claim, damage, loss, cost, expense, legal expenses, arising from or attributable to Contractor provision of services, its acts, or omissions or those of its agents, employees, sub-contractors, representative/s or other for whom TPT may be / may not be deemed responsible for in terms of the agreement.**

---

## C1.2 Contract Data

### Part two - Data provided by the *Contractor*

The tendering *Contractor* is advised to read both the NEC3 Engineering and Construction Contract - June 2005 (with amendments June 2006 and April 2013) and the relevant parts of its Guidance Notes (ECC3-GN) in order to understand the implications of this Data which the tenderer is required to complete. An example of the completed Data is provided on pages 156 to 158 of the ECC3 Guidance Notes.

Completion of the data in full, according to Options chosen, is essential to create a complete contract.

Clause	Statement	Data
10.1	The <i>Contractor</i> is (Name):	
	Address	
	Tel No.	
	Fax No.	
11.2(8)	The <i>direct fee percentage</i> is	%
	The <i>subcontracted fee percentage</i> is	%
11.2(18)	The <i>working areas</i> are the Site and	
24.1	The <i>Contractor's</i> key persons are:	
	1 Name:	
	Job:	
	Responsibilities:	
	Qualifications:	
	Experience:	
	2 Name:	
	Job	
	Responsibilities:	
	Qualifications:	
	Experience:	



TRANSNET PORT TERMINALS

TENDER NUMBER: iCLM EL 725/TPT

DESCRIPTION OF THE WORKS: THE REFURBISHMENT OF THE GRAIN ELEVATOR SUBSTATIONS AT THE EAST LONDON MULTI PURPOSE TERMINAL FOR TRANSNET SOC LTD (REG NO. 1990/000900/30) OPERATING AS TRANSNET PORT TERMINALS (HEREINAFTER REFERRED AS "TPT") FOR THE DURATION OF 12 MONTHS

		<b>CV's (and further key persons data including CVs) are appended to Tender Schedule entitled.</b>
11.2(14)	The following matters will be included in the Risk Register	
31.1	The programme identified in the Contract Data is	
<b>B</b>	<b>Priced contract with bill of quantities</b>	
11.2(21)	The <i>bill of quantities</i> is in	<b>C2 Part 2 Pricing Data Option B</b>
11.2(31)	The tendered total of the Prices is	(in figures)  (in words), excluding VAT
	<b>Data for Schedules of Cost Components</b>	<i>Note "SCC" means Schedule of Cost Components starting on page 60 of ECC, and "SSCC" means Shorter Schedule of Cost Components starting on page 63 of ECC.</i>

<b>B</b>	<b>Priced contract with bill of quantities</b>	<b>Data for the Shorter Schedule of Cost Components</b>		
41 in SSCC	The percentage for people overheads is:	<b>%</b>		
21 in SSCC	The published list of Equipment is the last edition of the list published by			
	The percentage for adjustment for Equipment in the published list is	<b>% (state plus or minus)</b>		
22 in SSCC	The rates of other Equipment are:	<b>Equipment</b>	<b>Size or capacity</b>	<b>Rate</b>



TRANSNET PORT TERMINALS

TENDER NUMBER: iCLM EL 725/TPT

DESCRIPTION OF THE WORKS: THE REFURBISHMENT OF THE GRAIN ELEVATOR SUBSTATIONS AT THE EAST LONDON MULTI PURPOSE TERMINAL FOR TRANSNET SOC LTD (REG NO. 1990/000900/30) OPERATING AS TRANSNET PORT TERMINALS (HEREINAFTER REFERRED AS "TPT") FOR THE DURATION OF 12 MONTHS

61 in SSCC	The hourly rates for Defined Cost of design outside the Working Areas are	<b>Category of employee</b>	<b>Hourly rate</b>
62 in SSCC	The percentage for design overheads is	<b>%</b>	
63 in SSCC	The categories of design employees whose travelling expenses to and from the Working Areas are included in Defined Cost are:		



TRANSNET PORT TERMINALS

TENDER NUMBER: iCLM EL 725/TPT

DESCRIPTION OF THE WORKS: THE REFURBISHMENT OF THE GRAIN ELEVATOR SUBSTATIONS AT THE EAST LONDON MULTI PURPOSE TERMINAL FOR TRANSNET SOC LTD (REG NO. 1990/000900/30) OPERATING AS TRANSNET PORT TERMINALS (HEREINAFTER REFERRED AS "TPT") FOR THE DURATION OF 12 MONTHS

---

## C1.3 Forms of Securities

### **Pro forma Performance Guarantee**

For use with the NEC3 Engineering & Construction Contract - June 2005 (with amendments June 2006 and April 2013)

The *conditions of contract* stated in the Contract Data Part 1 include the following Secondary Option:

Option X13: Performance bond

The pro forma document for this Guarantee is provided here for convenience but is to be treated as part of the *Works Information*.

The organisation providing the Guarantee does so by copying the pro forma document onto its letterhead without any change to the text or format and completing the required details. The completed document is then given to the *Employer* within the time stated in the contract.

The Performance Bond needs to be issued by an institution that are reasonably acceptable to the *Employer*.

Transnet may choose to not to accept an Issuer. Should the issuer not being accepted, the performance bond needs to be replaced by an issuer that are acceptable to Transnet. Issuers need to be verified for acceptance by Transnet before a performance bond is issued.

## Pro-forma Performance Bond (for use with Option X13)

(to be reproduced exactly as shown below on the letterhead of the Surety)

Transnet SOC Ltd  
C/o Transnet Port Terminals  
Transnet Corporate Centre  
138 Eloff Street  
Braamfontein  
Johannesburg  
2000

Date:

Dear Sirs,

### Performance Bond for Contract No. iCLM EL 725/TPT

With reference to the above numbered contract made or to be made between

**Transnet SOC Limited, Registration No. 1990/000900/30**

(the *Employer*) and

{Insert registered name and address of the *Contractor*}

(the *Contractor*), for

{Insert details of the *works* from the Contract Data}

(The refurbishment of the grain elevator substations at the East London Multi Purpose Terminal for Transnet SOC Ltd (Reg no. 1990/000900/30) operating as Transnet Port Terminals (hereinafter referred as "TPT") for the duration of 12 months).

I/We the undersigned

on behalf of the  
Guarantor

of physical address

.....  
.....  
.....  
.....

and duly authorised thereto do hereby bind ourselves as Guarantor and co-principal debtors in solidum for the due and faithful performance of all the terms and conditions of the Contract by the *Contractor* and for all losses, damages and expenses that may be suffered or incurred by the *Employer* as a result of non-performance of the Contract by the *Contractor*, subject to the following conditions:

1. The terms *Employer*, *Contractor*, *Project Manager*, *works* and *Completion Certificate* have the meaning as assigned to them by the *conditions of contract* stated in the Contract Data for the aforesaid Contract.
2. We renounce all benefits from the legal exceptions "Benefit of Excussion and Division", "No value received" and all other exceptions which might or could be pleaded against the validity of this bond, with the meaning and effect of which exceptions we declare ourselves to be fully acquainted.
3. The *Employer* has the absolute right to arrange his affairs with the *Contractor* in any manner which the *Employer* deems fit and without being advised thereof the Guarantor shall not have the right to claim his release on account of any conduct alleged to be prejudicial to the Guarantor. Without derogating from the foregoing compromise, extension of the construction period, indulgence, release or variation of the *Contractor's* obligation shall not affect the validity of this performance bond.
4. This bond will lapse on the earlier of
  - the date that the Guarantor receives a notice from the *Project Manager* stating that the *Completion Certificate* for the whole of the *works* has been issued, that all amounts due from the *Contractor* as certified in terms of the contract have been received by the *Employer* and that the *Contractor* has fulfilled all his obligations under the Contract, or
  - the date that the Surety issues a replacement Performance Bond for such lesser or higher amount as may be required by the *Project Manager*.
5. Always provided that this bond will not lapse in the event the Guarantor is notified by the *Project Manager*, (before the dates above), of the *Employer's* intention to institute claims and the particulars thereof, in which event this bond shall remain in force until all such claims are paid and settled.
6. The amount of the bond shall be payable to the *Employer* upon the *Employer's* demand and no later than 7 days following the submission to the Guarantor of a certificate signed by the *Project Manager* stating the amount of the *Employer's* losses, damages and expenses incurred as a result of the non-performance aforesaid. The signed certificate shall be deemed to be conclusive proof of the extent of the *Employer's* loss, damage and expense.
7. Our total liability hereunder shall not exceed the sum of:  
  
(say) \_\_\_\_\_  
  
R \_\_\_\_\_
8. This Performance Bond is neither negotiable nor transferable and is governed by the laws of the Republic of South Africa, subject to the jurisdiction of the courts of the Republic of South Africa



TRANSNET PORT TERMINALS  
TENDER NUMBER: iCLM EL 725/TPT  
DESCRIPTION OF THE WORKS: THE REFURBISHMENT OF THE GRAIN ELEVATOR SUBSTATIONS AT THE EAST LONDON MULTI PURPOSE TERMINAL FOR TRANSNET SOC LTD (REG NO. 1990/000900/30) OPERATING AS TRANSNET PORT TERMINALS (HEREINAFTER REFERRED AS "TPT") FOR THE DURATION OF 12 MONTHS

Signed at \_\_\_\_\_ on this \_\_\_\_\_ day of \_\_\_\_\_ 2024

Signature(s) \_\_\_\_\_

Name(s) (printed) \_\_\_\_\_

Position in Guarantor company \_\_\_\_\_

Signature of Witness(s) \_\_\_\_\_

Name(s) (printed) \_\_\_\_\_

TRANSNET PORT TERMINALS  
TENDER NUMBER: iCLM EL 725/TPT  
DESCRIPTION OF THE WORKS: THE REFURBISHMENT OF THE GRAIN ELEVATOR SUBSTATIONS AT THE EAST LONDON MULTI PURPOSE TERMINAL FOR TRANSNET SOC LTD (REG NO. 1990/000900/30) OPERATING AS TRANSNET PORT TERMINALS (HEREINAFTER REFERRED AS "TPT") FOR THE DURATION OF 12 MONTHS

---

## PART 2: PRICING DATA

Document reference	Title	No of pages
C2.1	Pricing instructions: Option B	5
C2.2	The <i>bill of quantities</i>	17



TRANSNET PORT TERMINALS

TENDER NUMBER: iCLM EL 725/TPT

DESCRIPTION OF THE WORKS: THE REFURBISHMENT OF THE GRAIN ELEVATOR SUBSTATIONS AT THE EAST LONDON MULTI PURPOSE TERMINAL FOR TRANSNET SOC LTD (REG NO. 1990/000900/30) OPERATING AS TRANSNET PORT TERMINALS (HEREINAFTER REFERRED AS "TPT") FOR THE DURATION OF 12 MONTHS

## C2.1 Pricing instructions: Option B

### 1. The *conditions of contract*

#### 1.1. How the contract prices work and assesses it for progress payments

Clause 11 in NEC3 Engineering and Construction Contract, June 2005 and 2013 (ECC) Option B states:

**Identified  
and defined  
terms**

11

11.2

(21) The Bill of Quantities is the *bill of quantities* as changed in accordance with this contract to accommodate implemented compensation events and for accepted quotations for acceleration.

(22) Defined Cost is the cost of the components in the Shorter Schedule of Cost Components whether work is subcontracted or not excluding the cost of preparing quotations for compensation events.

(28) The Price for Work Done to Date is the total of

- the quantity of the work which the *Contractor* has completed for each item in the Bill of Quantities multiplied by the rate and
- a proportion of each lump sum which is the proportion of the work covered by the item which the *Contractor* has completed.

Completed work is work without Defects which would either delay or be covered by immediately following work.

(31) The Prices are the lump sums and the amounts obtained by multiplying the rates by the quantities for the items in the Bill of Quantities.

This confirms that Option B is a re-measurement contract and the bill comprises only items measured using quantities and rates or stated as lump sums. Value related items are not used. Time related items are items measured using rates where the rate is a unit of time.

## 1.2. Function of the Bill of Quantities

Clause 55.1 in Option B states, "Information in the Bill of Quantities is not Works Information or Site Information". This confirms that instructions to do work or how it is to be done are not included in the Bill, but in the Works Information. This is further confirmed by Clause 20.1 which states, "The *Contractor* Provides the Works in accordance with the Works Information". Hence the *Contractor* does **not** Provide the Works in accordance with the Bill of Quantities. The Bill of Quantities is only a pricing document.

## 1.3. Guidance before pricing and measuring

Employers preparing tenders or contract documents, and tendering contractors are advised to consult the sections dealing with the bill of quantities in the NEC3 Engineering and Construction Contract (June 2005) Guidance Notes before preparing the *bill of quantities* or before entering rates and lump sums into the *bill*.

Historically bill of quantities based contracts in South Africa have been influenced by the different approaches of the civil engineering and building sectors of the industry through their respective discipline based standard forms of contract and methods of measurement. This is particularly apparent in the approach to the Preliminary and General bill. On the other hand, because ECC caters for a number of disciplines in the same contract, including electrical works, a different approach not currently found in local methods of measurement to the Preliminary & General bill items may have been used.

The NEC approach to the P & G bill assumes use will be made of method related charges for Equipment applied to Providing the Works based on durations shown in the Accepted Programme, fixed charges for the use of Equipment that is required throughout the construction phase, time related charges for people working in a supervisory capacity for the period required, and lump sum charges for other facilities or services not directly related to performing work items typically included in other parts of the bill.

## 2. Measurement and payment

### 2.1. Symbols

The units of measurement described in the Bill of Quantities are metric units abbreviated as follows:

Abbreviation	Unit
%	percent
h	hour
ha	hectare
kg	kilogram
kl	kilolitre
km	kilometre
km-pass	kilometre-pass
kPa	kilopascal
kW	kilowatt
l	litre
m	metre
mm	millimetre
m <sup>2</sup>	square metre
m <sup>2</sup> -pass	square metre pass
m <sup>3</sup>	cubic metre
m <sup>3</sup> -km	cubic metre-kilometre
MN	meganewton

MN.m	meganewton-metre
MPa	megapascal
No.	number
Prov sum <sup>1</sup>	provisional sum
PC-sum	prime cost sum
R/only	Rate only
sum	Lump sum
t	ton (1000kg)
W/day	Work day

## 2.2. General assumptions

- 2.2.1. Unless otherwise stated, items are measured net in accordance with the drawings, and no allowance has been made in the quantities for waste.
- 2.2.2. The Prices and rates stated for each item in the Bill of Quantities shall be treated as being fully inclusive of all work, risks, liabilities, obligations, overheads, profit and everything necessary as incurred or required by the *Contractor* in carrying out or providing that item.
- 2.2.3. Clause 63.13 in Option B provides that these rates and Prices may be used as a basis for assessment of compensation events instead of Defined Cost.
- 2.2.4. Where this contract requires detailed drawings, designs or other information to be provided, and no rates or prices are included in the *bill* specifically for such matters, then the *Contractor* is deemed to have allowed for all costs associated with such requirements within the tendered rates and Prices in the Bill of Quantities.

<sup>1</sup> Provisional Sums should not be used unless absolutely unavoidable. Rather include specifications and associated bill items for the most likely scope of work, and then change later using the compensation event procedure if necessary. This is because tenderers cannot programme effectively for unknown scopes of work

- 2.2.5. An item against which no Price is entered will be treated as covered by other Prices or rates in the *bill of quantities*. If a number of items are grouped together for pricing purposes, this will be treated as a single lump sum.
- 2.2.6. The quantities contained in the Bill of Quantities may not be final and do not necessarily represent the actual amount of work to be done. The quantities of work assessed and certified for payment by the *Project Manager* at each assessment date will be used for determining payments due and not the quantities given in the Bill of Quantities.
- 2.2.7. The short descriptions of the items of payment given in the *bill of quantities* are only for the purposes of identifying the items. More detail regarding the extent of the work entailed under each item is provided in the Works Information.

### **2.3. Departures from the *method of measurement***

### **2.4. Amplification of or assumptions about measurement items**

For the avoidance of doubt the following is provided to assist in the interpretation of descriptions given in the *method of measurement*. In the event of any ambiguity or inconsistency between the statements in the *method of measurement* and this section, the interpretation given in this section shall be used.



TRANSNET PORT TERMINALS  
TENDER NUMBER: iCLM EL 725/TPT

DESCRIPTION OF THE WORKS: THE REFURBISHMENT OF THE GRAIN ELEVATOR SUBSTATIONS AT THE EAST LONDON MULTI PURPOSE TERMINAL FOR TRANSNET SOC LTD (REG NO. 1990/000900/30) OPERATING AS TRANSNET PORT TERMINALS (HEREINAFTER REFERRED AS "TPT") FOR THE DURATION OF 12 MONTHS

## C2.2 The *bill of quantities*

East London Grain Elevator Substation Refurbishment						
ITEM	PAY REF	DESCRIPTION	UNIT	QTY	RATE	AMOUNT
		<b><u>SECTION 1</u></b>				
1		<b><u>PRELIMINARY &amp; GENERAL</u></b>				
		<b>NOTE:</b> Tenderers are to price this Schedule strictly in accordance with the Specifications and SANS 1200, where a conflict arises between these two documents the Specifications shall take precedence. Where a conflict arises between this Schedule and the Specifications, the Specifications shall take precedence. Tenderers shall study all relevant information before pricing this Schedule and the Schedule shall be priced to provide the complete Works				
		To be read in conjunction with but not limited to the following Project Technical Specification(s): Part C3: Works Information				
	<b>SANS 1200 A</b>	<b><u>GENERAL</u></b>				
<b>1.1</b>	<b>PSA 8.3</b>	<b><u>SCHEDULED FIXED-CHARGE ITEMS</u></b>				



TRANSNET PORT TERMINALS  
TENDER NUMBER: iCLM EL 725/TPT

DESCRIPTION OF THE WORKS: THE REFURBISHMENT OF THE GRAIN ELEVATOR SUBSTATIONS AT THE EAST LONDON MULTI PURPOSE TERMINAL FOR TRANSNET SOC LTD (REG NO. 1990/000900/30) OPERATING AS TRANSNET PORT TERMINALS (HEREINAFTER REFERRED AS "TPT") FOR THE DURATION OF 12 MONTHS

ITEM	PAY REF	DESCRIPTION	UNIT	QTY	RATE	AMOUNT
1.1.1	8.3.1	<b><u>Contractual requirements</u></b>				
		a) Sureties	Sum	1		
		b) Insurance of the works and plant	Sum	1		
		c) Third party or public liability insurance	Sum	1		
		d) Unemployment insurance	Sum	1		
		e) Performance security as per <i>Employer's</i> requirements	Sum	1		
	<b>PSA 8.3.2</b>	<b><u>ESTABLISHMENT OF FACILITIES ON THE SITE</u></b>				
1.1.2	PSA 8.3.2.1	<b><u>FACILITIES FOR CONTRACTOR</u></b>				
		a) Offices and storage sheds (1 No. Offices 1 No. Sheds)	Sum	1		
		e) Ablution and latrine facilities	Sum	1		
		f) Tools and equipment	Sum	1		



TRANSNET PORT TERMINALS  
TENDER NUMBER: iCLM EL 725/TPT

DESCRIPTION OF THE WORKS: THE REFURBISHMENT OF THE GRAIN ELEVATOR SUBSTATIONS AT THE EAST LONDON MULTI PURPOSE TERMINAL FOR TRANSNET SOC LTD (REG NO. 1990/000900/30) OPERATING AS TRANSNET PORT TERMINALS (HEREINAFTER REFERRED AS "TPT") FOR THE DURATION OF 12 MONTHS

ITEM	PAY REF	DESCRIPTION	UNIT	QTY	RATE	AMOUNT
		g) Water supplies, electric power and communications	Sum	1		
		h) Access	Sum	1		
<b>1.1.4</b>	<b>PSA-8.3.3</b>	<b><u>OTHER FIXED-CHARGE OBLIGATIONS</u></b>				
		a) Management meetings	Sum	1		
		b) Documentation control including provision and/ or submission for approval of all <i>Contractor's</i> documents as part of the execution of the works	Sum	1		
		c) Safety risk management including but not limited to the Safety Plan as required by the Occupational Health and Safety Act, Act 85 of 1993	Sum	1		
		d) Environmental management including but not limited to Environmental Method Statements in accordance with the Construction Environmental Management Plan	Sum	1		
		e) Quality assurance requirements	Sum	1		



TRANSNET PORT TERMINALS  
TENDER NUMBER: iCLM EL 725/TPT

DESCRIPTION OF THE WORKS: THE REFURBISHMENT OF THE GRAIN ELEVATOR SUBSTATIONS AT THE EAST LONDON MULTI PURPOSE TERMINAL FOR TRANSNET SOC LTD (REG NO. 1990/000900/30) OPERATING AS TRANSNET PORT TERMINALS (HEREINAFTER REFERRED AS "TPT") FOR THE DURATION OF 12 MONTHS

ITEM	PAY REF	DESCRIPTION	UNIT	QTY	RATE	AMOUNT
		f) Site security requirements	Sum	1		
		g) Programming	Sum	1		
		h) Industrial relations management	Sum	1		
		i) Operation and maintenance manuals of the installation, operation and maintenance manuals and drawings for the equipment under this contract				
		i) Draft copies, three [3] in number	Sum	1		
		ii) Final copies, number to be confirmed by <i>Employer</i>	Sum	1		
1.1.5	PSA-8.3.5	<b><i>Contractor's design</i></b>				
1.1.5.1	PSA-8.3.5.1	<u>Design including but not limited to:</u>				
		a) Engineering package including detailed manufacturer design of MV and LV distribution panels, medium voltage switch gear and associated protection & control systems panels,HVAC, Power Factor Correction and Fire Systems	Sum	1		



TRANSNET PORT TERMINALS  
TENDER NUMBER: iCLM EL 725/TPT

DESCRIPTION OF THE WORKS: THE REFURBISHMENT OF THE GRAIN ELEVATOR SUBSTATIONS AT THE EAST LONDON MULTI PURPOSE TERMINAL FOR TRANSNET SOC LTD (REG NO. 1990/000900/30) OPERATING AS TRANSNET PORT TERMINALS (HEREINAFTER REFERRED AS "TPT") FOR THE DURATION OF 12 MONTHS

ITEM	PAY REF	DESCRIPTION	UNIT	QTY	RATE	AMOUNT
		b) Drawing submissions (all submissions for approval and/ or review by the <i>Employer</i> )	Sum	1		
		c) Compilation and provision of as-built documentation in both electronic and hard copy format, including but not limited to test and commissioning certificates, check lists, drawings etc. <b>Note: All as-built drawings shall be provided in 4xCD roms with Adobe Acrobat (PDF &amp; Native format)</b>	Sum	1		
1.1.6	8.3.4	<b><u>REMOVAL OF SITE ESTABLISHMENT</u></b>				
		a) Removal of site establishment	Sum	1		
1.2	PSA 8.4	<b><u>TIME-RELATED ITEMS</u></b>				
		-				
	PSA 8.4	<b><u>SCHEDULED TIME-RELATED ITEMS</u></b>				
1.2.1	8.4.1	<b><u>Contractual requirements</u></b>				
		a) Sureties	Sum	1		



TRANSNET PORT TERMINALS  
TENDER NUMBER: iCLM EL 725/TPT

DESCRIPTION OF THE WORKS: THE REFURBISHMENT OF THE GRAIN ELEVATOR SUBSTATIONS AT THE EAST LONDON MULTI PURPOSE TERMINAL FOR TRANSNET SOC LTD (REG NO. 1990/000900/30) OPERATING AS TRANSNET PORT TERMINALS (HEREINAFTER REFERRED AS "TPT") FOR THE DURATION OF 12 MONTHS

ITEM	PAY REF	DESCRIPTION	UNIT	QTY	RATE	AMOUNT
		b) Insurance of the works and plant	Sum	1		
		c) Third party or public liability insurance	Sum	1		
		d) Unemployment insurance	Sum	1		
		e) Performance security as per <i>Employer's</i> requirements	Sum	1		
		f) Other	Sum	1		
	PSA 8.4.2	<b>OPERATION AND MAINTENANCE OF FACILITIES ON SITE, FOR DURATION OF CONSTRUCTION, EXCEPT WHERE OTHERWISE STATED</b>				
1.2.3	8.4.2.2	<b>FACILITIES FOR <i>CONTRACTOR</i></b>				
		a) Offices and storage sheds ( 1 No. Offices 1 No. Sheds)	Sum	1		
		b) Ablution and latrine facilities	Sum	1		



TRANSNET PORT TERMINALS  
TENDER NUMBER: iCLM EL 725/TPT

DESCRIPTION OF THE WORKS: THE REFURBISHMENT OF THE GRAIN ELEVATOR SUBSTATIONS AT THE EAST LONDON MULTI PURPOSE TERMINAL FOR TRANSNET SOC LTD (REG NO. 1990/000900/30) OPERATING AS TRANSNET PORT TERMINALS (HEREINAFTER REFERRED AS "TPT") FOR THE DURATION OF 12 MONTHS

ITEM	PAY REF	DESCRIPTION	UNIT	QTY	RATE	AMOUNT
		c) Tools and equipment	Sum	1		
		d) Access	Sum	1		
1.2.4	8.4.3	<b>SUPERVISION FOR DURATION OF CONSTRUCTION</b>				
		a) Supervision for the duration of construction	Sum	1		
1.2.5	8.4.4	<b>COMPANY AND HEAD OFFICE OVERHEAD COSTS FOR THE DURATION OF THE CONTRACT</b>				
		a) Company and head office overhead costs for the duration of the contract	Sum	1		
1.2.6	PSA-8.4.5	<b>OTHER TIME-RELATED OBLIGATIONS</b>				
		a) Management meetings	Sum	1		
		b) Documentation control including provision and/ or submission for approval of all <i>Contractor's</i> documents as part of the execution of the works	Sum	1		



TRANSNET PORT TERMINALS  
TENDER NUMBER: iCLM EL 725/TPT

DESCRIPTION OF THE WORKS: THE REFURBISHMENT OF THE GRAIN ELEVATOR SUBSTATIONS AT THE EAST LONDON MULTI PURPOSE TERMINAL FOR TRANSNET SOC LTD (REG NO. 1990/000900/30) OPERATING AS TRANSNET PORT TERMINALS (HEREINAFTER REFERRED AS "TPT") FOR THE DURATION OF 12 MONTHS

ITEM	PAY REF	DESCRIPTION	UNIT	QTY	RATE	AMOUNT
		c) Occupational Health and Safety Specification compliance	Sum	1		
		d) Construction Environmental Management Plan compliance	Sum	1		
		e) Quality assurance requirements	Sum	1		
		f) Site security requirements (PSIRA Registered)	Sum	1		
		g) Programming and progress reporting	Sum	1		
		j) Transportation	Sum	1		
		<b>TOTAL CARRIED TO SUMMARY</b>				



TRANSNET PORT TERMINALS  
TENDER NUMBER: iCLM EL 725/TPT

DESCRIPTION OF THE WORKS: THE REFURBISHMENT OF THE GRAIN ELEVATOR SUBSTATIONS AT THE EAST LONDON MULTI PURPOSE TERMINAL FOR TRANSNET SOC LTD (REG NO. 1990/000900/30) OPERATING AS TRANSNET PORT TERMINALS (HEREINAFTER REFERRED AS "TPT") FOR THE DURATION OF 12 MONTHS

ITEM NO.	ITEM DESCRIPTION	QUANTITY	UNIT	SUPPLY RATE	INSTALLATION RATE	TOTAL
	<p><b><u>SECTION 2</u></b></p> <p><b>NOTE</b></p> <p>This Bill of Quantities shall be read in conjunction with the drawings, works information and the specifications and shall be priced to provide a complete installation, i.e. the supply where required, installation, testing and commissioning plus handing over of the fully functional equipment / installation. <b>The Contractor to furnish all design and shop drawings if applicable and any associated equipment specifications for approval prior to manufacturing and delivery to site</b></p>					
	To be read in conjunction with but not limited to the following Project Technical Specification(s): Part C3: Works Information					
<b>A</b>	<b>PREPARATION WORKS FOR THE PROPOSED SUBSTATION</b>					
ITEM NO.	ITEM DESCRIPTION	QUANTITY	UNIT	SUPPLY RATE	INSTALLATION RATE	TOTAL
1	Disconnect and removal of the existing MV switchgear, LV switchgear and battery bank to be replaced.	2	sum			
					<b>TOTAL</b>	



TRANSNET PORT TERMINALS  
TENDER NUMBER: iCLM EL 725/TPT

DESCRIPTION OF THE WORKS: THE REFURBISHMENT OF THE GRAIN ELEVATOR SUBSTATIONS AT THE EAST LONDON MULTI PURPOSE TERMINAL FOR TRANSNET SOC LTD (REG NO. 1990/000900/30) OPERATING AS TRANSNET PORT TERMINALS (HEREINAFTER REFERRED AS "TPT") FOR THE DURATION OF 12 MONTHS

<b>B</b>						
<b>MEDIUM VOLTAGE SWITCHGEAR</b>						
<b>ITEM NO.</b>	<b>ITEM DESCRIPTION</b>	<b>QUANTITY</b>	<b>UNIT</b>	<b>SUPPLY RATE</b>	<b>INSTALLATION RATE</b>	<b>TOTAL</b>
1	Design, supply, and install a new 1250A 11kV incomer VCB panel.	2	ea			
2	Design, supply, and install a new 1250A 11kV bus section VCB panel.	1	ea			
3	Design, supply, and install a new 630 11kV feeder VCB panel.	3	ea			
4	Design, supply a new spare 630 11kV feeder VCB panel.	1	ea			
5	Design supply and install a 11kV bus-riser panels/bus-bar Earth /VT panels.	1	ea			
6	Design, supply, install and commission a complete arc ducting and protection system for the 11kV switchgear	1	Sum			
7	Design, supply, install a battery bank (enclosed in a cabinet) and battery terminal unit for the 11kV switchgear complete with protection and wiring.	1	Sum			
8	Provision of racking tools	1	Sum			
<b>TOTAL</b>						
<b>C</b>						
<b>LOW VOLTAGE SWITCHGEAR</b>						
<b>ITEM NO.</b>	<b>ITEM DESCRIPTION</b>	<b>QUANTITY</b>	<b>UNIT</b>	<b>SUPPLY RATE</b>	<b>INSTALLATION RATE</b>	<b>TOTAL</b>
1	Design, supply, and install a new LV switchgear including new standard terminations for the existing incomer and feeder.	1	Sum			
2	design, supply, and install a control panel for the proposed MV switchgear complete with cabling.	1	Sum			
<b>TOTAL</b>						



TRANSNET PORT TERMINALS

TENDER NUMBER: iCLM EL 725/TPT

DESCRIPTION OF THE WORKS: THE REFURBISHMENT OF THE GRAIN ELEVATOR SUBSTATIONS AT THE EAST LONDON MULTI PURPOSE TERMINAL FOR TRANSNET SOC LTD (REG NO. 1990/000900/30) OPERATING AS TRANSNET PORT TERMINALS (HEREINAFTER REFERRED AS "TPT") FOR THE DURATION OF 12 MONTHS

<b>D</b>						
<b>ELECTRICAL, LIGHTING AND POWER</b>						
<b>ITEM NO.</b>	<b>ITEM DESCRIPTION</b>	<b>QUANTITY</b>	<b>UNIT</b>	<b>SUPPLY RATE</b>	<b>INSTALLATION RATE</b>	<b>TOTAL</b>
1	Design, supply, and install a new lighting and small power	1	Sum			
<b>TOTAL</b>						
<b>E</b>						
<b>TRANSFORMERS</b>						
<b>ITEM NO.</b>	<b>ITEM DESCRIPTION</b>	<b>QUANTITY</b>	<b>UNIT</b>	<b>SUPPLY RATE</b>	<b>INSTALLATION RATE</b>	<b>TOTAL</b>
1	Design supply and install a stainless-steel containment tray around the existing transformers	3	ea			
<b>TOTAL</b>						
<b>F</b>						
<b>MEDIUM VOLTAGE CABLE TERMINATION</b>						
<b>ITEM NO.</b>	<b>ITEM DESCRIPTION</b>	<b>QUANTITY</b>	<b>UNIT</b>	<b>SUPPLY RATE</b>	<b>INSTALLATION RATE</b>	<b>TOTAL</b>
1	Supply new 630A Feeder MV plug type terminations designed to EN 50181 and DIN 47637.	14	ea			
2	Supply new 1250A Incomer MV plug type terminations designed to EN 50181 and DIN 47637.	7	ea			
<b>TOTAL</b>						



TRANSNET PORT TERMINALS  
TENDER NUMBER: iCLM EL 725/TPT

DESCRIPTION OF THE WORKS: THE REFURBISHMENT OF THE GRAIN ELEVATOR SUBSTATIONS AT THE EAST LONDON MULTI PURPOSE TERMINAL FOR TRANSNET SOC LTD (REG NO. 1990/000900/30) OPERATING AS TRANSNET PORT TERMINALS (HEREINAFTER REFERRED AS "TPT") FOR THE DURATION OF 12 MONTHS

<b>G Earthing and Lightning Protection</b>						
<b>ITEM NO.</b>	<b>ITEM DESCRIPTION</b>	<b>QUANTITY</b>	<b>UNIT</b>	<b>SUPPLY RATE</b>	<b>INSTALLATION RATE</b>	<b>TOTAL</b>
1	Design, supply, and install earthing and lightning surge protection for the proposed substation upgrades.	1	Sum			
<b>TOTAL</b>						
<b>H Cables, Routes, and Building Modifications</b>						
<b>ITEM NO.</b>	<b>ITEM DESCRIPTION</b>	<b>QUANTITY</b>	<b>UNIT</b>	<b>SUPPLY RATE</b>	<b>INSTALLATION RATE</b>	<b>TOTAL</b>
1	Replacement of old chequered plates and sealing of cable entry/exit opening	1	Sum			
2	Provisional sum for the building refurbishments.					
2.1	Prepare, which shall include the filling of cracks, and repaint internal walls including ceilings for all substations rooms.	1	Sum			
2.2	Provision of an automated pump system complete with all piping and level detectors to automatically detect and pump the water out of the MV cable trenches.	1	Sum			
2.3	Design supply and installation of a 300cm to 500cm steel platform for the 11kV switchgear. This is to allow for sufficient bending radius of the cables. The platform shall be 3Cr12 as a minimum.	1	Sum			
2.4	Prepare and repaint the substations rooms floors with an acceptable industry specification for switchgear rooms.	1	Sum			



TRANSNET PORT TERMINALS

TENDER NUMBER: iCLM EL 725/TPT

DESCRIPTION OF THE WORKS: THE REFURBISHMENT OF THE GRAIN ELEVATOR SUBSTATIONS AT THE EAST LONDON MULTI PURPOSE TERMINAL FOR TRANSNET SOC LTD (REG NO. 1990/000900/30) OPERATING AS TRANSNET PORT TERMINALS (HEREINAFTER REFERRED AS "TPT") FOR THE DURATION OF 12 MONTHS

ITEM NO.	ITEM DESCRIPTION	QUANTITY	UNIT	SUPPLY RATE	INSTALLATION RATE	TOTAL
3	Provisional sum for the testing, joining and replacement of cables.					
3.1	Supply, install, and commission 150mm <sup>2</sup> XLPE SWA Cu 11kV 3 core cable	300	m			
3.2	Supply, install, and commission 95mm <sup>2</sup> XLPE SWA Cu 11kV cable	300	m			
3.3	630mm <sup>2</sup> XLPE SWA Cu 11kV 1 core cable	200	m			
3.4	Select, Supply, and install MV cables transition joints (150mm <sup>2</sup> , 11kV, 3 core Paper oil impregnated to 3 core XLPE cable.)	4	ea			
3.5	Select, Supply, and install MV cables transition joints (95mm <sup>2</sup> , 11kV, 3 core XLPE cable to 1 core XLPE cables).	5	ea			
3.6	Select, Supply, and install MV cables transition joints (150mm <sup>2</sup> , 11kV, 3 core XLPE cable to 1 core XLPE cables).	3	ea			
4	Replacement of substation doors and provision of signages.	1	Sum			
5	Refurbishment of Transformers	3	ea			
					<b>TOTAL</b>	



TRANSNET PORT TERMINALS  
TENDER NUMBER: iCLM EL 725/TPT

DESCRIPTION OF THE WORKS: THE REFURBISHMENT OF THE GRAIN ELEVATOR SUBSTATIONS AT THE EAST LONDON MULTI PURPOSE TERMINAL FOR TRANSNET SOC LTD (REG NO. 1990/000900/30) OPERATING AS TRANSNET PORT TERMINALS (HEREINAFTER REFERRED AS "TPT") FOR THE DURATION OF 12 MONTHS

<b>I Power System Protection</b>						
<b>ITEM NO.</b>	<b>ITEM DESCRIPTION</b>	<b>QUANTITY</b>	<b>UNIT</b>	<b>SUPPLY RATE</b>	<b>INSTALLATION RATE</b>	<b>TOTAL</b>
1	Load flow, short circuit and protection grading study and configuration.	1	Sum			
2	Provision of a standalone ETAP licenced software.	1	ea			
<b>TOTAL</b>						
<b>J Power Quality</b>						
<b>ITEM NO.</b>	<b>ITEM DESCRIPTION</b>	<b>QUANTITY</b>	<b>UNIT</b>	<b>SUPPLY RATE</b>	<b>INSTALLATION RATE</b>	<b>TOTAL</b>
1	Design, supply, and installation of a 500kVar, five stepped with 100kVars, 11kV PFC complete with Harmonic filtration power quality solution equal or similar approved to the ABBACUS E-series technology. Incoming cables and terminations to be priced as part of the complete solution for this item.	1	Sum			
<b>TOTAL</b>						



TRANSNET PORT TERMINALS  
TENDER NUMBER: iCLM EL 725/TPT

DESCRIPTION OF THE WORKS: THE REFURBISHMENT OF THE GRAIN ELEVATOR SUBSTATIONS AT THE EAST LONDON MULTI PURPOSE TERMINAL FOR TRANSNET SOC LTD (REG NO. 1990/000900/30) OPERATING AS TRANSNET PORT TERMINALS (HEREINAFTER REFERRED AS "TPT") FOR THE DURATION OF 12 MONTHS

<b>K HVAC and Fire</b>						
<b>ITEM NO.</b>	<b>ITEM DESCRIPTION</b>	<b>QUANTITY</b>	<b>UNIT</b>	<b>SUPPLY RATE</b>	<b>INSTALLATION RATE</b>	<b>TOTAL</b>
1	Design, supply and installation of the fire detection and suppression system.	1	Sum			
2	Design, supply and installation of the HVAC/climate control plant (Pressurising).	1	Sum			
<b>TOTAL</b>						
<b>L Testing and Commissioning</b>						
<b>ITEM NO.</b>	<b>ITEM DESCRIPTION</b>	<b>QUANTITY</b>	<b>UNIT</b>	<b>SUPPLY RATE</b>	<b>INSTALLATION RATE</b>	<b>TOTAL</b>
1	Test and commission the entire installation. The contractor shall issue test, certificates, user manuals and as-built drawings. <b>(Refer to works information)</b>	1	Sum			
<b>TOTAL</b>						
<b>TOTAL TENDER AMOUNT</b>						



TRANSNET PORT TERMINALS

TENDER NUMBER: iCLM EL 725/TPT

DESCRIPTION OF THE WORKS: THE REFURBISHMENT OF THE GRAIN ELEVATOR SUBSTATIONS AT THE EAST LONDON MULTI PURPOSE TERMINAL FOR TRANSNET SOC LTD (REG NO. 1990/000900/30) OPERATING AS TRANSNET PORT TERMINALS (HEREINAFTER REFERRED AS "TPT") FOR THE DURATION OF 12 MONTHS

ITEM	DESCRIPTION	UNIT	QTY	AMOUNT
	<b>SUMMARY</b>			
	<b>SECTION 1</b>			
1	Preliminary and General	sum	1	
	<b>SECTION 2</b>			
A	Preparation works for the proposed substation upgrades	sum	1	
B	Medium voltage switchgear	sum	1	
C	Low voltage switchgear	sum	1	
D	Electrical, Lighting and Power	sum	1	
E	Transformers	sum	1	
F	Medium Voltage Cable Termination	sum	1	
G	Earthing and Lightning Protection	sum	1	
H	Cables, Routes, and Building Modifications	sum	1	
I	Power System Protection	sum	1	



TRANSNET PORT TERMINALS

TENDER NUMBER: iCLM EL 725/TPT

DESCRIPTION OF THE WORKS: THE REFURBISHMENT OF THE GRAIN ELEVATOR SUBSTATIONS AT THE EAST LONDON MULTI PURPOSE TERMINAL FOR TRANSNET SOC LTD (REG NO. 1990/000900/30) OPERATING AS TRANSNET PORT TERMINALS (HEREINAFTER REFERRED AS "TPT") FOR THE DURATION OF 12 MONTHS

J	Power Quality	sum	1	
K	HVAC and Fire	sum	1	
L	Testing and Commissioning	sum	1	
	<b>TOTAL DIRECT COST</b>			

**Note:** Total of the Prices must be transferred to the Form of Offer



**PART C3: SCOPE OF WORK**

<b>Document reference</b>	<b>Title</b>	<b>No of page</b>
C3.1	This cover page	1
	<i>Employer's Works</i> Information	71
	<i>Annexures</i>	1
<b>Total number of pages</b>		<b>73</b>





DOCUMENTATION DISTRIBUTION, REVISION AND APPROVAL HISTORY

REVISION NUMBER	DATE	DISTRIBUTION/ REVISION	PREPARED BY	REVIEWED BY	APPROVED BY
00	July 2024	00	Nowhi Hloma	McDonald Tsubella	Adriaan Stadler

**SIGNATORIES:**

Compiled by:  09/07/2024  
Nowhi Hloma  
Senior Project Manager  
Date

Reviewed by:  09/07/2024  
McDonald Tsubella  
Engineering Manager  
Date

Reviewed by:  09.07.2024  
Lonwabo Mkalipi  
Engineering Technician  
Date

Approved by:  12.07.2024  
Adriaan Stadler  
Senior Engineering Manager  
Date



## Contents

1	Description of the <i>Works</i> .....	7
1.1	Background .....	7
1.2	Problem Statement .....	8
1.3	Project High Level Scope: .....	8
1.4	<i>Employer's</i> objectives .....	9
1.5	Interpretation and terminology.....	9
2	Employer and Contractor design .....	13
2.1	<i>Employer's</i> design and provisions.....	13
2.1.1	Electrical:	13
2.1.2	Mechanical:	13
2.2	<i>Contractor's</i> design .....	13
3	Procedure for submission and acceptance of <i>Contractor's</i> design.....	16
3.1	The <i>Contractor</i> shall address the following procedures:.....	16
3.2	Review and Acceptance of <i>Contractor</i> Documentation .....	17
3.3	As-built drawings, Operating manuals and Maintenance schedules .....	17
4	Construction.....	19
4.1	Temporary <i>Works</i> , Site services & construction constraints.....	19
4.1.1	Restrictions to access on Site, roads, walkways and barricades	20
4.1.2	Barricades and fencing around site	21
4.1.3	Restrictions to access on Site	21
4.1.4	People restrictions on Site; hours of work, conduct and records:	21
4.1.5	Health and safety facilities on Site	22
4.1.6	Title to Materials from dismantling, demolition and excavation	22
4.1.7	Cooperating with and obtaining acceptance of others	23
4.1.8	Publicity and progress photographs	23
4.1.9	<i>Contractor's</i> Equipment	24
4.1.10	Equipment provided by the Employer	24
4.1.11	Site services and facilities:	24
4.1.12	Connections to services for <i>Contractor's</i> use:	25
4.1.13	Facilities provided by the <i>Contractor</i> :	25
4.1.14	The <i>Contractor</i> provides the following facilities for the Project Manager and Supervisor:	27
4.1.15	Control of noise, dust, water and waste	28
4.1.16	Sequences of construction or installation	28



---

4.1.17	Giving notice of work to be covered up	28
4.1.18	The Contractor complies with the following constraints in the execution of the Works:	28
5	Completion, testing, commissioning, and correction of Defects.....	29
5.1	The <i>work</i> to be done by the Completion Date .....	29
5.2	Use of the <i>Works</i> before Completion has been certified.....	29
5.3	Materials facilities and samples for tests and inspections .....	30
5.4	Pre-Commissioning Tests and Commissioning .....	30
5.5	Take over procedures .....	32
5.5.1	Access given by the Employer for correction of Defects	33
5.5.2	The Contractor complies with the following constraints and procedures of the Employer where the Project Manager arranges access for the Contractor after Completion:	33
5.6	Operational maintenance after Completion .....	33
5.7	Performance tests after Completion .....	34
5.8	Training and technology transfer .....	34
6	Plant and Materials Standards and Workmanship .....	34
6.1	Plant and Materials.....	34
7	Detailed Engineering Scope of Works.....	35
7.1	Legal Requirements Regarding Designs.....	35
7.1.1	Reference Documents	35
7.1.2	Legislations	35
7.1.3	Standards	36
7.1.4	Specifications	37
7.2	Service Conditions .....	37
7.3	Low Voltage Power System .....	37
7.4	Medium Voltage Power System .....	38
7.5	Design <i>Works</i> to be executed by the <i>Contractor</i> .....	39
7.6	Construction <i>Works</i> to be executed by the <i>Contractor</i> .....	40
7.6.1	MV Switchgear Installation	40
7.6.2	LV Switchgear Installation	42
7.6.3	Cable Installation	42
7.6.4	Transformers in the substation/s.	43
7.6.5	Design, Supply, and Installation, Testing, Commissioning and Handover of new HVAC systems	43



7.6.6	Design, Supply, Installation, Testing, Commissioning and Handover of Fire Protection systems.	44
7.6.7	Substation building refurbishments.	46
7.6.8	Testing and Commissioning of the installation	46
8	List of Drawings .....	47
8.1	Drawings issued by the <i>Employer</i> .....	47
9	Management and start up .....	47
9.1	Management meetings .....	47
9.2	Documentation Control .....	49
9.3	Safety risk management .....	50
9.4	Environmental constraints and management .....	51
9.4.1	General	51
9.5	Environmental Obligation .....	52
9.6	Quality assurance requirements .....	53
9.6.1	General Requirements	53
9.7	Quality Policy .....	53
9.8	Project Quality Plan .....	54
9.9	Submissions and Records .....	55
9.10	Programme .....	55
9.10.1	General	55
9.10.2	Programme submission	56
9.10.3	Contract Programme (Baseline)	56
9.10.4	Programme Information:	56
9.10.5	Meet the required timeframes:	57
9.10.6	Resourcing & Equipment:	57
9.10.7	Revision to contract Schedule	57
9.10.8	Supplementary Programmes	57
9.10.9	Cash Flow	57
9.10.10	Progress Reporting	58
9.10.11	Progress Monitoring and Review	58
9.10.12	Monthly Status Report	58
9.11	Staffing .....	59
9.12	<i>Contractor's</i> management, supervision, and key people .....	59
9.13	Training <i>Workshops</i> .....	63

---

9.14	Contract change management .....	63
9.15	Provision of bonds and guarantees .....	63
9.16	Records of Defined Cost, payments & assessments of compensation events kept by <i>Contractor</i> ..	64
10	Plant and Materials .....	64
11	Subcontracting .....	64
12	Procurement .....	65
12.1	Code of Conduct .....	65
12.2	Prohibition of bribes, Kickbacks, Unlawful Payments, and Other Corrupt Practices .....	65
12.3	Conflicts of Interest .....	67
12.4	The Contractor's Invoices .....	67
12.5	People .....	68
12.6	Contractor Liability .....	68
12.7	Industrial Action by Contractors Employees .....	68
13	SPECIFIC GOALS.....	70
13.1	General Conditions .....	70
14	Definitions .....	71
15	Annexures .....	73
	Table 1: Abbreviations .....	10
	Table 2: Description of Terminology.....	12
	Table 3: Data Packs .....	29
	Table 4: List of South African and International Codes used in the development of this document. ....	35
	Table 5: List of all South African and International Standards used in the development of this document. ....	36
	Table 6: List of all Transnet Specifications used in the development of this document.....	37
	Table 7: Drawings.....	47
	Table 8: Communication Plan .....	47
	Table 9: Preference Points .....	71

## SECTION 1

### 1 Description of the Works

#### 1.1 Background

The East London Multi-Purpose Terminal (EL MPT) consists of a Car Terminal, Grain Terminal, Breakbulk and Container handling facilities. The EL Grain Elevator is the largest grain silo in the South African coastline. Grain is received from a vessel and stacked to the silos through the grain elevator and/or grain is offloaded from the silo to the vessel through the grain elevator. The grain elevator consists of 8 bucket elevators and 12 conveyor belts. It is supplied by the Basement substation that is connected on a ring feed with 12th floor substation. Both these substations are connected to the national Grid through TNPA main substation.

The purpose of the substations are to supply power to the end user by varying the voltage levels, frequency and other aspects. Substations are key to the infrastructure of Transnet Port Terminals by supplying various equipment and machinery with the required power in order to ensure continues operations.

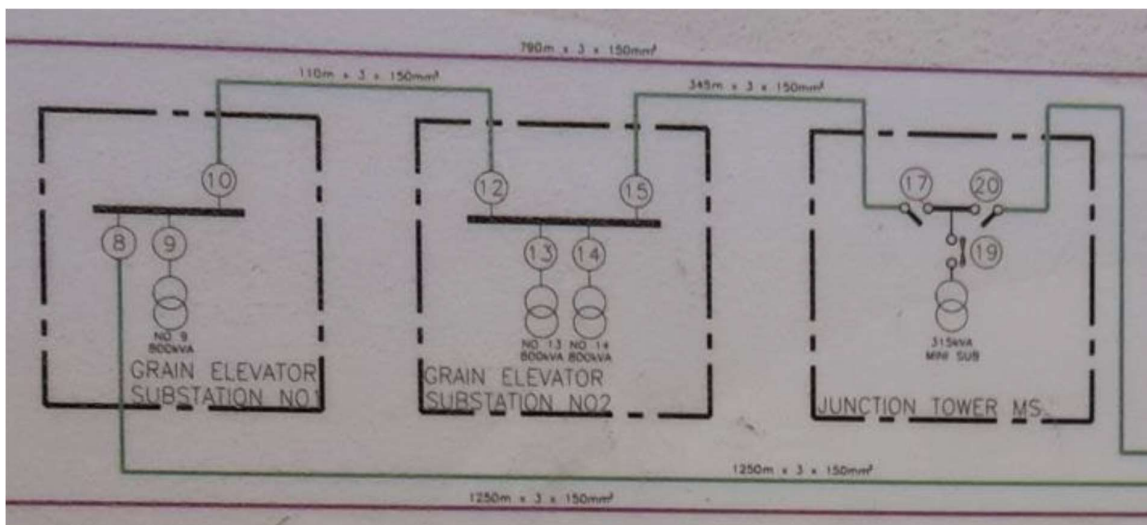

Fig 1: EL MPT MV Schematic

The line diagram above shows the two-grain elevator substations fed from TNPA Main substation.



## 1.2 Problem Statement

East London Grain Elevator substations were commissioned in 1963 and have been operating with equipment that have reached its life span and over. The substations still have old equipment such as oil circuit breakers, mechanical operated relays, CT's, VT` s, old analogue voltmeters, and ammeters as well as deteriorating Paper Insulated Lead Covered (PILC) cables. The Grain Elevator substations supplies power to the grain elevator Facility.

TPT is responsible for the maintenance and safety their own substations. As part of maintenance activities, switching is necessary. The existing equipment and technology in the substations are old and poses a safety risk to the Maintenance personnel and the facility itself. The existing equipment is obsolete and result in maintenance challenges due to lack of replacement spares on the market. It is important to ensure the required spares are readily available in case of a breakdown to ensure substation equipment operate safely and reliable.

## 1.3 Project High Level Scope:

The works that the *Contractor* is to perform include but is not limited to the following:

- Upgrade of Grain Elevator Substation 1
- Upgrade of Grain Elevator Substation 2
- The *employer's* scope of works is based on the conditional assessment reports that will be made available to the contractor. This shall include a network single line diagram which will be provided to assist with pricing of the works.
- High level designs and specifications shall be provided by the *employer*.
- Supply and install medium voltage switchgear.
- Supply and install low voltage switchgear.
- Size, supply and install Battery Tripping Unit.
- Supply and install anti condensation heaters.
- Supply and install power factor correction.
- Supply and install LV cables.
- Earthing and lightning protection system for the substation.
- Design, Supply, Installation, Testing, Commissioning, Certification and Handover of HVAC positive pressurised system and HVAC cooling system for substation 1 and substation 2.
- Perform MV switchgear protection setting calculations, relay coordination and grading, and relay programming.
- Test, commission, and handover the MV and LV switchgear.



- Make good of the substation walls and floors.
- Design, Supply, Installation, Testing, Commissioning, Handover and Certification of Gaseous Fire Detection and Suppression System as well as relevant fire extinguishers and fire signage associated with substation 1 and substation 2.
- The contractor shall provide all the required designs in addition to the *employer's* high-level designs for the completion of the works.
- All designs shall be submitted to the employer's engineer for acceptance. All design developments which the employer deems to be critical shall be progressively communicated with the employer for alignment.
- During construction, Transnet's Port electrical appointed personnel shall perform all the required switching and control work permits.
- The Contractor shall submit a notification of switching to the Project Manager 7 working days prior to the required work being performed.
- Commission and testing of the entire installation and handover to the *Employer*.

#### **1.4 Employer's objectives**

The Employer is Transnet Port Terminals (TPT) and the eventual owners of the works. TPT requires the refurbishment of a substations in the Port of East London.

The Employer's objectives are to achieve Completion of the Works by meeting the Completion Date whilst still maintaining the highest environmental, quality and safety standards and whilst minimising disruptions to on-going port and terminal operations and the operations and activities of other stakeholders.

#### **1.5 Interpretation and terminology**

For the purposes of this contract for all matters regarding technical decisions, Acceptance of Engineering related technical documents, Testing, Commissioning and any matters pertaining to the context of the Occupational Health and Safety Act, the Contractor is required to cooperate with the *Employer's* Engineers/Professional Engineers as per Core Clause 25.1 and Core Clause 14.2 as delegated by the *Project Manager*, for the former and as applicable in the context. The instructions received by the *Contractor* shall be interpreted as lawful in matters pertaining to the former if the Instruction has been endorsed by both the *Project Manager* and the Employer's Engineers/Professional Engineers as applicable in the context. The Employer's Owners Team shall be named post award of the contract and prior to commencement of the Works.

The Contractor is further advised that, in compliance to NEC3 ECC Core Clause 25.1, that co-operation with the *Employer's* Engineers and other representatives of the Employer (Others) is a requirement of this contract and the Contractor is to allow, grant and facilitate all reasonable access that may be required by the *Employer's* Engineers and Others as applicable, for the provision of the Works.

The following abbreviations are used in this Works Information:

Table 1: Abbreviations

<b>Abbreviation</b>	<b>Meaning given to the abbreviation</b>
A	Ampere
ACB	Air Circuit Breaker
AIA	Authorised Inspection Authority
AIS	Air Insulated Switchgear
ASHRAE	The American Society of Heating, Refrigerating and Air-Conditioning Engineers
BBBEE	Broad Based Black Economic Empowerment
CEMP	Construction Environmental Management Plan
CEMP <sub>r</sub>	Construction Environmental Management Programme
CD	Compact Disc
CDR	<i>Contractor</i> Documentation Register
CDS	Contractor Documentation Schedule
CHSO	Construction Health and Safety Officer
CIRP	Contractor's Industrial Relations Practitioner
CM	Construction Manager
COC	Certificate of Compliance
COLTO	Committee of Land and Transport Officers
CRL	<i>Contractor</i> Review Label
CSHEO	<i>Contractor's</i> Safety, Health and Environmental Officer
D	Diameter
DSTI	Daily Safety Task Instruction
DTI	Department of Trade and Industry
DWG	Drawings
EA	Environmental Authorization
ECC	Engineering and Construction Contract
EL	East London
ECSA	Engineering Council of South Africa
EO	Environmental Officer
FAT	Factory Acceptance Test
FEL	Front End Loading
FIC	Field Inspection Checklist



GIS	Gas Insulated Switchgear
HAW	Hazard Assessment <i>Workshop</i>
HAZOP	Hazard and Operability Study
HS	Health and Safety
HSSP	Health and Safety Surveillance Plan
HVAC	Heating, Ventilation and Air Conditioning
INC	Independent Nominated Consultant
IP	Industrial Participation
IR	Industrial Relations
IPP	Industrial Participation Policy
IPO	Industrial Participation Obligation
IPS	Industrial Participation Secretariat
IRCC	Industrial Relations Co-ordinating Committee
ISPS	International Ship and Port Facility Security
JSA	Job Safety Analysis
km	Kilo meter
kVA	Kilo-Volt Ampere
LV	Low Voltage
LT	Low Tension
m	metre
MV	Medium Voltage
mm	millimetre
MCB	Miniature Circuit Breaker
MCC	Motor Control Centre
MCCB	Moulded Case Circuit Breaker
Native	Original electronic file format of documentation
ONAN	Oil Natural Air Natural
PES	Project Environmental Specifications
PHA	Preliminary Hazard Assessment
PIRM	Project Industrial Relations Manager
PIRPMP	Project Industrial Relations Policy and Management Plan
PLA	Project Labour Agreements
PSIRA	Private Security Industry Regulatory Authority
PSIRM	Project Site Industrial Relations Manager
PSPM	Project Safety Program Manager
PSSM	Project Site Safety Manager
ProgEM	Programme Environmental Manager
ProjEM	Project Environmental Manager
PVC	Polyvinyl Chloride
QA	Quality Assurance

QC	Quality Control
R&D	Research and Development
SACPCMP	The South African Council for the Project and Construction Management Professions
SANS	South African National Standards
SAT	Site Acceptance Test
SASRIA	South African Special Risks Insurance Association
SCADA	Supervisory Control and Data Acquisition
SES	Standard Environmental Specification
SHE	Safety, Health and Environment
SHEC	Safety, Health and Environment Co-ordinator
SHEQ	Safety, Health, Environment and Quality
SIP	Site Induction Programme
SMP	Safety Management Plan
SOC	Safety Observation Conversations
SOC	State Owned Company
SSRC	Site Safety Review Committee
SF6	Sulphur Hexafluoride
TEU	Twenty-foot Equivalent Unit
TNPA	Transnet National Ports Authority
TPT	Transnet Port Terminals
VT	Voltage Transformer

Table 2: Description of Terminology

Terminology	Description
Employer	For the purpose of this document, the Employer shall be regarded as Transnet Port Terminals
<i>Contractor</i>	For the purposes of this document the <i>Contractor</i> refers to the person(company) whom has been awarded the contract to perform the works stipulated by the employer
Specialist	Is a person or company appointed by the <i>Contractor</i> or employer who has significant expertise in execution of a particular work
Employer's Engineer	For the purpose of this document, the Employer's Engineer is a technical representative appointed by the Employer who holds a Bsc/Beng/Btech/Ndip and registered with ECSA as Pr Eng/Pr Tech in a relevant field of engineering. The purpose for the Employer's Engineer is to review, support and accept the designs, documents and drawings for this project.
Accepted	For the purpose of this document, the term "Accepted" shall be used to describe that an activity/task/document/drawing/design/calculation is received and believed to be true. However, by Accepting any of the above items does not



	alleviate legal and ethical responsibilities that is carried by the ECSA responsible signatory for the item
Supported	For the purpose of this document, the term "Supported" shall be used to describe that an activity/task/document/drawing/design/calculation is received and the contents herein with are agreed upon with encouragement to proceed.

## 2 Employer and Contractor design

### 2.1 Employer's design and provisions

The *Employer's* design for the *Works* is:

#### 2.1.1 Electrical:

- a. The high-level designs for the MV reticulation, for the Substation.
- b. The selection of electrical Plant and switchgear associated with the MV systems.
- c. The substation building and plant layout.
- d. The *Employer* grants the *Contractor* a licence to use the copyright in design data presented to the *Contractor* for the purpose of the *Works* of this contract ONLY.

#### 2.1.2 Mechanical:

None

### 2.2 Contractor's design

All designs undertaken by the Contractor as per the below clauses are required to be endorsed by an ECSA Registered Professional Engineer/Professional Technologist suitably experienced in the relevant discipline.

#### 2.2.1.1 The Contractor is to design the following parts of the Works:

- a. All supporting infrastructure required. These may include, but is not necessarily limited to, cableways, cable support systems, conduit systems and arrangement, piped systems and pipe support systems, and the selection of fasteners and fastening systems for these items, where required and not specified, referenced or detailed by the *Employer*.
- b. All designs of all MV and LV distribution panels.
- c. The Earthing and Lightning Protection design.
- d. Detail design of HVAC positive pressurised ventilation system and air conditioning cooling system for substation 1 and substation 2.



- e. Detail design of Gaseous fire detection and suppression system for substation 1 and substation 2.
- f. Detail design of fire protection in terms of fire extinguishers, fire and escape signage for substation 1 and substation 2.
- g. The Contractor shall submit detailed drawings and Workshop details for all designs to the Project Manager for acceptance by the Employer's Consultant or the Employer's Engineers.
- h. All and any equipment, formwork, and temporary work associated with the provision of the Works.
- i. The Contractor is responsible in his design for the overall integration of the design of the Works with the existing infrastructure.
- j. The Contractor is wholly responsible for all design coordination, integration and liaison activities involved in the Works, and shall take all measures necessary and make all arrangements for activities such as meetings, inspections, endorsements, and any other activities required for the timeous completion of the Works and to the appropriate quality. When these activities require the involvement of the Employer's Professional Engineering team or any other stakeholders, the Contractor is required to make these arrangements with due consideration of the Employer's Professional Engineering team's availability and the availability of other stakeholders.
- k. The *Contractor* shall submit drawings and Workshop details for all designs to the Project Manager for acceptance by the Employer's Consultant or the Employer's Engineers.
- l. All residual design responsibility and overall responsibility for the total design solution for the Works rests with the Contractor.
- m. The *Contractor* shall engage the services of ECSA registered Engineers and/or Technologists for all aspects of the Works for which the Contractor is to design.
- n. The Contractor shall thus be wholly accountable and responsible for all aspects of the employer's high-level designs.
- o. The *Contractor* shall thus be wholly accountable and responsible for all aspects of his designs, including the implementation of all Statutory Safety, Health and Environmental Regulations of South Africa and the requirements, specifications, and regulations of the Employer pertaining to Health and Safety, Environment, Quality and Engineering.
- p. The *Contractor* shall be wholly accountable and responsible for the implementation of the aspects of his designs including commissioning, putting into service, and handover of his constructed designs to the Employer, and his duly appointed ECSA registered Engineers shall be held accountable and responsible for these aspects of the Works for the lifetime duration of the Works.



#### 2.2.1.2 Use of *Contractor's* design

- a. The *Contractor* grants the *Employer* a licence to use the copyright in all design data presented to the *Employer* in relation to the Works for any purpose in connection with refurbishment, repair, and maintenance of the Works with such licence being capable of transfer to any third party without the consent of the *Contractor*.
- b. The *Contractor* vests in the *Employer* full title guarantee in the intellectual property and copyright in the design data created in relation to the Works of this contract.

#### 2.2.1.3 Design of Equipment

- a. The *Contractor* submits his design details for the following categories of his proposed principal Equipment to the *Project Manager* for his information only:
  - Any formwork required to Provide the Works temporary electrically powered compressed air systems and pneumatic equipment that may be required to Provide the Works.
  - Small electrically powered equipment
  - Equipment designed for the lifting of personnel to access any areas necessary to Provide the Works, which are not at ground level.
  - Equipment designed for the lowering of personnel to access any areas necessary to Provide the Works, which are below ground level.
- b. The following principal Equipment categories deployed for the *Contractor* to Provide the Works require its design to be accepted by the *Project Manager*.
  - Temporary petrol- or diesel-powered compressed air systems and pneumatic equipment that may be required to Provide the Works
  - Small petrol- or diesel-powered equipment
  - Specialist Equipment required to Provide the Works
  - Rigging platforms and specialised rigging Equipment that may be required by the *Contractor* to Provide the Works.
  - Launching platforms and incremental launching equipment that may be required by the *Contractor* to Provide the Works
  - Temporary access platforms, ladders, walkways, scaffolds, and any other temporary structures required to Provide the Works.
  - The design of Equipment is considered in terms of this contract as *Contractor's* design.

#### 2.2.1.4 Equipment required to be included in the Works

- a. Any shuttering/formwork that is left in-situ as required by the design of the *Works* and necessary for the provision of the *Works*.



### **3 Procedure for submission and acceptance of *Contractor's* design**

#### **3.1 The *Contractor* shall address the following procedures:**

- a. The *Contractor's* documentation shall be issued to the *Project Manager* under cover of the *Contractor's* Transmittal Note indicating all Contract references (i.e. Project No, Contract No, etc.) as well as the *Contractor's* Project Document Number, Revision Number, Title and chronological listing of transmitted documentation. Formats of *Contractor* data submitted is dependent on the project procedure and shall be specified by the *Project Manager*, upon the notified request of the *Contractor*.
- b. The *Contractor* shall deliver both hard copies and electronic media copies (CD Rom) to the *Project Manager* either at the address stated within the Contract Data or at the Project site office.
- c. All electronic documentation shall be submitted by the *Contractor* in Adobe Acrobat (.PDF) and native file format.
- d. Acceptance of documentation by the *Project Manager* will in no way relieve the *Contractor* of the responsibility for the correctness of information, or conformance with his obligation to Provide the Works. This obligation rests solely with the *Contractor*.
- e. After review, a copy of the original reviewed/marked-up drawing/document, with the *Project Manager's* consolidated comments and document status marked on the *Contractor* Review Label, is scanned and the copy shall be returned to the *Contractor* under cover of the project's Transmittal Note for revision or re-submittal as instructed.
- f. The *Contractor* shall allow the *Project Manager* 14 working days (unless otherwise stated and agreed) to review and respond to the *Contractor's* submission of their documentation, i.e. from time of receipt by the project to the time of despatch. However, work shall proceed without delay in the event of late return of the documentation by the *Project Manager* with prior notification in writing by the *Contractor*.
- g. On receipt of the reviewed documentation the *Contractor* shall make any modifications requested/marked-up and resubmit the revised documentation to the *Project Manager* within 14 working days. Queries regarding comments/changes should be addressed with the *Project Manager* prior to re-submittal.
- h. Any re-submittals, which have not included the changes/comments identified, will be returned to the *Contractor* to be corrected. The *Contractor* shall re-issue the revised documentation incorporating all comments and other specified details not included in the previous issue within 2 working days of receipt of the marked-up document.
- i. The *Contractor* is required to undertake design safety reviews with the *Project Manager*, the NEC *Supervisor*, the *Employer's* Engineer's and Professional team, the *Employer's* Health and Safety



Officers, the *Employer's* Environmental Officers, the *Employer's* Quality Assurance and Quality Control Officers and any other Specialists and/or Subject Matter Experts (SME) as deemed by the *Employer* necessary for the provision of the *Works*.

- j. In undertaking the *Works* (including all incidental services required), the *Contractor* shall conform and adhere to the requirements of the *Contractor* Document Submittal Requirements Standard. The *Contractor* shall submit his designs to the *Project Manager* for acceptance before commencing with any manufacturing or construction.

### **3.2 Review and Acceptance of *Contractor* Documentation**

- a. The *Contractor* submits documentation as the '*Works* Information' requires to the *Project Manager* for review and acceptance.
- b. In undertaking the '*Works*' (including all incidental services required), the *Contractor* shall conform and adhere to the requirements of the '*Contractor* Document Submittal Requirements' Standard.
- c. The *Project Manager* may withhold acceptance of a submission if the document submission requirements stated in the *Works* Information are not adhered to.
- d. The *Contractor* grants the *Employer* a licence to use the copyright in all design data presented to the *Employer* in relation to the *Works* for any purpose in connection with the construction, reconstruction, refurbishment, repair, maintenance and extension of the *Works* with such licence being capable of transfer to any third party without the consent of the *Contractor*.
- e. All documents submitted by the *Contractor* to the *Project Manager* for review and acceptance must display the date on which the document was submitted, be adequately signed off by the relevant ECSA professional designer which must also include the designer's professional registration number on the document/drawing. Failing in providing this information on the documents/drawings will render the drawing/document incomplete and will result in it not being reviewed by the *Employer* and will subsequently be send back for correction and resubmission.

### **3.3 As-built drawings, Operating manuals and Maintenance schedules**

The *Contractor* provides the following:

- a. As-Built/Final Documentation
  - In undertaking the *Works* (including all incidental services required), the *Contractor* shall conform and adhere to the requirements of the *Contractor* Document Submittal Requirements Standard.
- b. Installation, Maintenance and Operating Manuals and Data Books



- The *Contractor* prepares two (2) marked up hard copies of the latest revision of the Employer documents/drawings to represent the As-Built/Final status.
- The mark-ups shall be in RED pencil or pen and be complete and accurate. The Contractor submits same to the Project Manager under cover of a *Contractor's* Transmittal Note.
- The *Contractor* provides manuals in an A4 hard covered, red, grease and waterproof binder, using 2 ring type binders. The manuals are well indexed and user friendly and include a summarized Table of Contents.
- Drawings and charts larger than A4 are folded and those greater than A3 are enclosed in an A4 plastic pocket of adequate strength.
- The *Contractor* submits the draft Table of Contents to the Project Manager for acceptance prior to the compilation and official submittal of the manuals.
- The originals of all brochures shall be issued to the Project Manager. When a general brochure is applicable to a range of equipment, then the specific item, catalogue number or model number shall be stated, which is best achieved by introducing a separate index page, which cross-references the specific item to a tag number.
- The address, phone numbers, fax numbers and reference numbers of all Sub-Contractors is provided.
- Where manuals include drawings that still need to be revised to "As-Built" status, and such manuals are required prior to 'As-Built' status, the manual will not be considered to be in its final form until the "As-Built" version of each such drawing has been incorporated. The required number of copies of the manual (s) shall be as specified by the Project Manager and submitted per type or model number of equipment included in the contract, or as specified by the Project Manager. A typical example of what the binder/file (s) shall be marked with on the spine and the front cover is as follows: -

- Project No./Name
- Manual Title, e.g. Installation, Maintenance and Operating Manual
- FBS No. and Title
- Manual Numbering (e.g. Volume 1 of 2, etc.)
- Contract Number
- *Contractor* Name

- a. Unless otherwise stated in the CDS, the required number of copies of all As-Built/Final/Data Packs shall be:

3 x hard copies (Full size)

4 x CD Roms with Adobe Acrobat (.pdf) and "Native" formats



## 4 Construction

### 4.1 Temporary Works, Site services & construction constraints

- a. The *Contractor* shall comply with the requirements of the *Employer* regarding site entry and security control, permits, and Site regulations.
- b. The *Contractor* complies with the following requirements of the *Employer*:
  - The *Contractor* shall attend all necessary Safety Inductions and ensure that all personnel engaged in the provision of the *Works* are inducted as directed by the *Project Manager*, *NEC Supervisor*.
  - The *Contractor* and all personnel engaged in the provision of the *Works* shall attend all Safety Inductions as required by the TPT Control Officer as directed through the Project Manager.
  - The *Contractor* and all personnel engaged in the provision of the *Works* shall attend all Safety Inductions as required by the Employer's Safety Officer, Employer's Electrical Engineer and/or as directed by the Project Manager.
  - All work subsequent to the energizing of the proposed substation shall be supervised by a Transnet Category C "Green" for work that does not involve MV switching operations; and a Transnet Category A "Brown" certified officer for work that involves MV switching operations.
- c. The *Contractor* shall make arrangements for the Transnet Category A "Brown" officer to arrange access to the substations during the execution of the *Works*.
  - All personnel working or accessing the substation are required to sign the Substation Register and indicate the time of entry, time of exit and the details of the work carried out.
- d. The *Contractor* shall obtain access permits from the TPT Permit Office, and the *Employer's* Safety Officer before accessing the site.
- e. The *Contractor* shall obtain the relevant work permits from the TPT control officer, and the *Employer's* Safety Officer before performing any work.
- f. The *Contractor* shall at all times comply with the Transnet MV Safety Instructions "Blue Book" whilst providing the *Works*.
- g. The Safety Inductions, Access Permits and Work Permits are part of this contract and the *Contractor* shall make allowance for it in his *Price* and *Schedule*.
- h. The *Contractor* shall ensure that all relevant safety inductions and access permits are obtained well before the Site Access Date as reflected in the Contract Data.



- i. The Port of EL is a designated Security Areas under the ISPS requirement, and in terms of this, all access into the Port area will be strictly controlled. Compliance to these security requirements, including labour transport and access requirements, obtaining and maintaining access cards for the *Contractor's* personnel on Site is part of this contract, and the *Contractor* shall make allowance for it in his *Price* and *Schedule*.
- j. The *Contractor* shall obtain the TPT entry permits for all the *Contractor's* personnel within the Port of EL in accordance with the access control requirements of the Port and the *Contractor* shall make allowance for it in his *Price* and *Schedule*.
- k. The *Contractor* is also required to obtain the relevant permits for his Sub-*Contractors* and all suppliers. The *Contractor* is required to make applications for these permits on behalf of his workers, suppliers and Sub *Contractors*, and is to nominate a single person to liaise with the relevant port and terminal authorities and the *Contractor* shall make allowance for it in his *Price* and *Schedule*.
- l. The *Contractor* provides all staff working within the Project with *Contractor* identification cards which detail the person's name, identity number and the foreman / engineer responsible. The provision of construction personnel with ID cards is considered part of this contract and shall be made by the *Contractor* to a standard acceptable to the *Project Manager* and the *Contractor* shall make allowance for it in his *Price* and *Schedule*.
- m. The *Contractor* is to be in constant consultation and cooperation with the Port's security operations to ensure compliance with all the required security procedures and the *Contractor* shall make allowance for it in his *Price* and *Schedule*.

#### **4.1.1 Restrictions to access on Site, roads, walkways and barricades**

Access route to Site:

- a. All vehicles are subject to security checks and all Plant and Equipment brought into the facility and leaving the facility are required to be security cleared by the relevant authorities (Project Manager and TPT Security Manager) before access or exit is granted, as the situation may require.
- b. The Contractor is required to arrange for the clearing of the items with the Project Manager and the TPT Security Manager well in advance of the access or exit requirement to avoid delays in the provision of the Works.
- c. The Contractor ensures that any of his staff, labour and Equipment moving outside of his allocated Site and Working Areas does not obstruct the Employer's operations if any. To this end access routes are allocated and co-ordinated by the Contractor in liaison with the Project Manager.



- d. The Contractor ensures the safe passage of Contractor's traffic to and around the Site and Working Areas at all times. This includes providing flagmen, protective barriers, signage, etc for protection, direction and control of traffic.
- e. The Contractor shall provide designated, signed and demarcated walkways for all personnel who are required to traverse between the different working areas on site. Personnel outside of the designated walkways are required to be conducting work activities, and when traversing, are required to use the designated walkways.
- f. The Contractor plans and organises his work in such a manner so as to cause the least possible disruption to the Employer's operations or other possible contractors on site.

#### **4.1.2 Barricades and fencing around site**

- a. The Contractor shall be responsible for providing a temporary barricade fence between the port operations and the construction site and maintaining, providing, and/or relocating, if required for construction purposes; the ISPS standard palisade fence to ensure the boundary fence is continuous, and the Contractor shall make allowance for it in his Price and Schedule.
- b. The Contractor shall ensure that his site access gate is manned 24hrs a day for the duration of the Works and over any builder's breaks, by a Security Provider acceptable to the Project Manager and registered with the PSIRA and the Contractor shall make allowance for it in his Price and Schedule. Refer to Annexure O.
- c. The Contractor shall obtain permission from the Project Manager prior to erecting and/or dismantling including temporarily relocating any section of the ISPS standard boundary fencing.

#### **4.1.3 Restrictions to access on Site**

- a. The Contractor is prohibited from entering the Employer's Operational Areas.
- b. The Contractor plans and organises his work in such a manner so as to cause the least possible disruption to the Employer's operations.
- c. The Contractor ensures that all his construction staff, labour, and Equipment remains within his allocated and fenced off construction areas.

#### **4.1.4 People restrictions on Site; hours of work, conduct and records:**



- a. The working hours shall be in accordance with the requirements of the Department of Labour or with the agreement of the relevant trade unions. This information relating to working hours shall be supplied to the Project Manager prior to commencement of the proposed working hours.
- b. All Contractor's staff and labour engaged in the provision of the Works shall comply with Employer's safety requirements and are equipped with all necessary PPE, high visibility apparel and, when working within two meters of the quay wall, floating apparel.
- c. In the event that the Contractor requests to work overtime, the Contractor will be liable for the supervision cost required from the Employers team during the Works.
- d. The Contractor keeps daily records of his people, Plant and equipment engaged on the Site and Working Areas (including Sub-Contractors) with access to such daily records available for inspection by the Project Manager and/or the PIRM at all reasonable times. (summarised activity and progress for the day must be mentioned).
- e. Minimum requirements of people employed on the Site are as follows:
  - South African identity document or passport/ visa and work permit for foreign nationals;
  - Employment of local labour only for unskilled and semi-skilled job categories as per PIRPMP;
  - Secondment of skilled core/ permanent employees if skills are not locally available;
  - Pre-employment medical examinations; and
  - Induction in IR matters and conditions of employment on the Project.
- f. The *Contractor* complies with the requirements of the IRCC involving the engineering construction *Contractors* engaged (including all future *Contractors*) by the *Employer*.

#### **4.1.5 Health and safety facilities on Site**

- a. The *Contractor* is referred to the Health and Safety specifications: Annexure C.

#### **4.1.6 Title to Materials from dismantling, demolition and excavation**

- a. The *Contractor* has no title to any materials arising from dismantling, excavation and demolition in the performance of the *Works* with title to such materials remaining with the *Employer*. The *Project Manager* shall instruct the *Contractor* how to label, mark, set aside and/or dispose of such materials for the benefit of the *Employer* in accordance with ECC3 Clause 73.1

#### **4.1.7 Cooperating with and obtaining acceptance of others**

The *Contractor* performs the *Works* and co-operates with:

- a. The Contractor performs the Works and co-operates with the Employer (including the agents of the Employer) who operate on Site during the entire duration of the Contract period.
- b. The Contractor performs the Works and co-operates with the Employer's Engineers, (including the agents of the Employer's Engineers) who operate on Site during the entire duration of the Contract period.
- c. The Contractor performs the Works and co-operates with The Employer's Management Consultants (including the agents of the Management Consultants) who operate on Site during the entire duration of the Contract period.
- d. The Contractor performs the Works and co-operates with The TPT Control Office and agents of the TPT Control Office who operate on Site during the entire duration of the Contract period.
- e. The Contractor performs the Works and co-operates with others, of whom the Contractor is to be notified once appointed by the Employer, who operate on Site during the entire duration of the Contract period.

#### **4.1.8 Publicity and progress photographs**

- a. The Contractor shall obtain the permission and approval of the *Employer* before erecting any notice boards, using the details of the contract in any advertising media or revealing any details of the contract to the public.
- b. The *Contractor* does not advertise the contract or the project to any third party, nor communicate directly with the media (in any jurisdiction) whatsoever without the express written notification and consent of the *Project Manager*.
- c. The *Contractor* provides a notice board showing the *Employers* Details, The *Employers* Agent's Details and the *Contractor's* Details at the site.
- d. The *Contractor* shall submit the graphic design and the structural support designs of the notice board to the *Project Manager* for acceptance before fabricating or erecting it.
- e. The *Contractor* provides progress photographs at monthly intervals in digital format as part of the *Contractor's* monthly programme narrative report. The photos shall include detailed, close photos of construction activities as well as aerial photographs showing general progress.

#### **4.1.9 Contractor's Equipment**

- a. The *Contractor* keeps daily records of his Equipment used on Site and the Working Areas (distinguishing between owned and hired Equipment) with access to such daily records available for inspection by the *Project Manager* at all reasonable times.
- b. The *Contractor* complies with the following permissions and restrictions in the use of Equipment as required by the *Employer*:
  - Equipment used by the Contractor to Provide the Works shall be assembled and disassembled within the Contractors work area and site boundaries or lay-down areas as authorised by the Project Manager.
  - The Contractor is required to remove all equipment that is not part of the Works from site after completion of the Works and before de-establishment of the site.
  - All and any equipment used by the Contractor for the provision of the Works shall comply to the Employer's SHEQ regulations and restrictions, or any other statutory Health and Safety requirements as directed by the Project Manager in liaison with the Employer's Engineers or the Employers Consultants.

#### **4.1.10 Equipment provided by the Employer**

The Employer shall not provide any Equipment to the Contractor for the purposes of this contract.

#### **4.1.11 Site services and facilities:**

The *Employer* provides the following facilities for the *Contractor*:

- a. For the duration of the Contract, the *Project Manager* will provide an area, free of charge, for the *Contractor* to establish his offices, lay down areas, stores, *Workshops*, and other *Contractor's* Equipment.
- b. The locations of the potential lay down areas will be identified at the site clarification meeting. The *Contractor* may establish a site camp anywhere within the boundary of this area that does not impede the provision of the *Works*.
- c. The *Contractor* shall ensure that the area used has a suitable continuous security fence and the necessary access gates.
- d. The area may be used for offices, stores, casting yards, repair shops, concrete batch Plants and any other engineering work that may be required.
- e. All preparation and fencing, etc. shall be done by the *Contractor* and shall be allowed for in his Price, this includes clearing away and leaving clean and clear at completion.
- f. The *Contractor* shall provide everything else necessary for Providing the *Works*.



#### **4.1.12 Connections to services for Contractor's use:**

- a. A supply point for Potable Water on Site.
- b. The connection points for the Potable water shall be identified at the site clarification meeting.
- c. The *Supervisor* will arrange for the closing of the water valves during the installation of the metered take-off points.
- d. The *Contractor* shall be responsible for providing water for all other Working Areas where not provided by *Employer*.
- e. The *Contractor* shall provide everything else necessary for Providing the *Works* in accordance with this contract and attached Annexures.
- f. The *Contractor* shall be provided with the power point for reticulation to a designated laydown area. The contractor shall provide a CoC for the power installation to the site establishment.
- g. Wherever the *Employer* provides facilities (including, *inter alia*, temporary power, water, waste disposal, telecommunications etc) for the *Contractor's* use within the Working Areas and the *Contractor* adapts such facilities for use, then the *Contractor* makes good and provides full reinstatement to the land (including all apparatus of the *Employer* and Others in, on or under the land) and surrounding areas to its original standard upon dismantling of such facilities and hand-back to the *Employer*.

#### **4.1.13 Facilities provided by the Contractor:**

- a. The *Contractor* ensures that the site establishment area is compliant with the relevant safety regulations and restrictions, is clearly sign posted, and has a suitable security fence, lighting and the necessary access control gates.
- b. All costs for preparation of the site establishment area are to be allowed for in the *Contractor's* Price.
- c. The *Contractor* submits details of the layout of his site establishment to the *Project Manager* for his acceptance.
- d. The *Contractor* is responsible for his own connection to the *Employer's* services and for the reticulation of his services from the connection point. The cost of reticulation and all other usage costs associated with the provision of services are included in Price.
- e. The *Contractor* provides the *Project Manager* with a "Certificate of Compliance" (COC), by an "Accredited" Person as defined by the OHS Act, in respect of his Construction Power electrical



installation. The *Project Manager* only makes construction power available upon receipt of the COC.

- f. The *Supervisor* (or his nominated representative) conducts routine inspections of the *Contractor's* construction power reticulation and power tools. If found to be un-safe and / or non-compliant with statutory requirements, the electrical power supply is disconnected until the *Contractor* rectifies all defaults.
- g. The *Contractor* provides, at his cost, a sufficient number of toilets and maintains them in a clean and sanitary working condition.
- h. The *Contractor* provides temporary lighting and fencing around every section occupied by him during the phased construction of the *Works*.
- i. Such fencing demarcates and secures the construction area. The fencing is erected before any work starts and is removed only upon completion of the work in that area.
- j. The *Contractor* includes for all costs for such lighting and fencing, including access control into and out of these restricted areas.
- k. Wherever the *Contractor* provides facilities (either his own or for the *Project Manager* and/or *Supervisor*) and all items of equipment, involving, inter alia, offices, accommodation, laboratories, materials storage, etc, within the Working Areas, then the *Contractor* makes good and provides full reinstatement to the land (including all apparatus of the *Employer* and Others in, on or under the land) and surrounding areas to its original standard, upon dismantling of such facilities and items of Equipment.
- l. Upon completion, and within one month of the date of acceptance of the *Works*, the *Contractor* completely removes from the Site and Working Areas all his Equipment, including the foundations of any structures, stores, office accommodation or any other asset belonging to him, and leaves the Site and Working Areas in a tidy condition to the satisfaction of the *Project Manager*.
- m. No excess or discarded materials or equipment may be buried or dumped within the port boundary.
- n. Demolition of all temporary structures surfaces etc. shall be first approved by the *Project Manager* prior to the work being carried out.
- o. The *Employer* does not provide any security for the Site and Working Areas. The *Contractor* provides same and indemnifies and holds indemnified the *Project Manager* and *Employer* against any claims and actions that may arise out of Site and Working Area security.
- p. No housing is available for the *Contractor's* employees. The *Contractor* makes his own arrangements to house his employees and transports them to site in a closed vehicle specifically designed for passenger transport (bus or similar) accepted by the *Project Manager*.



- q. Wherever the *Employer* provides facilities for the *Contractor's* use and the *Contractor* adapts such facilities for use, then the *Contractor* makes good and provides full reinstatement to the land (including all apparatus of the *Employer* and Others in, on or under the land) and surrounding areas to its original standard upon dismantling of such facilities and hand-back to the *Employer*.
- r. The *Contractor* shall provide, maintain and remove lockable portable chemical type toilets.
- s. The *Contractor* shall provide a suitably sized construction power supply by means of either municipal supply, or Generation Plant equipment, as required.
- t. The *Contractor* shall be wholly responsible for the provision of this power supply and shall make all the necessary arrangements for the supply, and the maintenance of the supply for the duration of the *Works*.
- u. The *Contractor* shall submit his invoices and/or municipal billing statements for the power supply as part of his Preliminary and General claims for the duration of the *Works*.

**4.1.14 The Contractor provides the following facilities for the Project Manager and Supervisor:**

- a) Furnished air-conditioned offices. (1 No in accordance to SANS 12200A 8.3.2.1a)
- b) Wherever the *Contractor* provides facilities (either his own or for the *Project Manager* and/or *Supervisor*) and all items of Equipment, involving, *inter alia*, offices, accommodation, laboratories, Materials storage, compound areas etc, within the Working Areas, then the *Contractor* makes good and provides full reinstatement to the land (including all apparatus of the *Employer* and Others in, on or under the land) and surrounding areas to its original standard, upon dismantling of such facilities and items of Equipment.
- c) Unless explicitly stated as a responsibility of the *Employer*, Connections to Services for *Contractors' use*, all residual requirements for the provision of facilities and all items of Equipment necessary for the *Contractor* to Provide the *Works* remains the responsibility of the *Contractor*.
- d) Existing premises, inspection of adjoining properties and checking work of Others, the *Contractor* will be held responsible for any damage to the existing structures and surfacing caused by the *Contractor* during the execution of this contract; fair wear and tear excluded, and shall repair it to the satisfaction of the *Project Manager* on conclusion of the *Works*.
- e) For this purpose, a joint inspection with the *Project Manager* will be carried out prior to occupation of the site(s) and any existing damage noted.
- f) The *Contractor* is required to forward a photographic report following the inspection to the *Project Manager* for record purposes.

#### **4.1.15 Control of noise, dust, water and waste**

The *Contractor* complies with the following:

- a. Before moving Equipment onto the Site and Working Areas and commencing the Works, the Contractor submits his/her proposed methods of construction which demonstrate the measures taken to avoid and or reduce any environmental and health issues arising from dust, noise and vibration for acceptance by the Project Manager.
- b. The Contractor is to provide dust suppression as per the CEMP, PES and SES documents to ensure that dust levels resulting from the *Contractor's* construction traffic are kept to the required safety and environmental standards as specified in the relevant project environmental specifications.

#### **4.1.16 Sequences of construction or installation**

The *Contractor* complies with the following:

- a. The Contractor is hereby informed of the requirements of maintaining the continuity of supply to the Port of EL, and is required to arrange and sequence his/her Works so as to ensure that there is no disruption to the Port Operations.
- b. Should it be impossible to avoid a disruption as described in (a) above, the *Contractor* shall notify the Project Manager, Supervisor and the Employers Engineers 21 working days before the anticipated disruption and request authorization to commence with the aspect of the Works that will cause the disruption. The *Contractor* shall not proceed without said authorization to proceed.

#### **4.1.17 Giving notice of work to be covered up**

- a. The *Contractor* notifies the *Project Manager* in writing of any elements of the *Works* which are to be covered up. This notification is given not less than 48 (forty-eight) hours prior to the proposed covering up.
- b. The *Contractor* shall not cover the *Works* without the authorization of the *Project Manager*.
- c. The *Contractor* shall notify the *Project Manager* of any tests and inspections required by the *Employers* Quality Management Procedures and/or the *Employers* Engineers within 14 working days prior to the advent of inspection or tests that require witnessing.

#### **4.1.18 The Contractor complies with the following constraints in the execution of the Works:**

- a. The *Contractor* is required not to disrupt the continuity of electrical supply to the Port of East London during the provision of the *Works*.

- b. Should it be impossible to avoid a disruption as described in (a) above, the *Contractor* shall notify the *Project Manager* 21 working days before the anticipated disruption and request authorization to commence with the aspect of the *Works* that will cause the disruption. The *Contractor* shall not proceed without said authorization to proceed.

## 5 Completion, testing, commissioning, and correction of Defects

### 5.1 The *work* to be done by the Completion Date

- a. On or before the Completion Date or Sectional Completion Date, the *Contractor* shall have done everything required to Provide the *Works* including removal of his/her establishment and equipment from the respective sites but excluding the work listed below which may be done after the Completion Date but in any case before the dates stated in this contract.
- b. The *Project Manager* cannot certify Completion until all the work except that listed below has been done and is also free of Defects, which would have, in his/her opinion, prevented the *Employer* from using the *Works* and others from doing their work.

Table 3: Data Packs

Item of work	To be completed by
Submission of all data packs, quality assurance records and as-built drawings	30 days after Completion

### 5.2 Use of the *Works* before Completion has been certified.

The *Employer* uses the following part / parts of the *Works* before Completion is certified by the *Project Manager* which do not constitute take over by the *Employer* for the reason(s) stated:

- a) All Cable, Switchgear, Protection relays, Control Systems Plant and Software or any other Electrical or Mechanical Plant installed by the Contractor so that the Employer may maintain the functionality of systems and existing Plant that is required by the Employer to conduct the Employers operational activities, and the operational activities of TPT.
- b) All Cable, Switchgear, Protection relays, Control Systems Plant and Software or any other Electrical or Mechanical Plant installed by the Contractor so that the Employer may maintain the continuity of the Electrical Supply to the Port of EL.

- c) Any temporary or permanent Lighting installation installed by the Contractor that may be required by the Employer to be used for the night-time operational activities of TPT or others, as required by the Project Manager.

### **5.3 Materials facilities and samples for tests and inspections**

The *Contractor* provides the *Employer* with the following materials, facilities and samples during the provision of the *Works*, as per ECC Clause 40.2:

- a. The Contractor is required to provide all materials, facilities and samples for any tests required.
- b. The Contractor shall furnish samples of any Plant that is other than, or different to, that specified by the Employer's Engineers, to the Project Manager for Acceptance by the Employer's Engineers. The Contractor is prohibited from installing said Plant without the required prior authorization from the Project Manager.
- c. The Contractor shall furnish samples of any Plant that is other than, or different to, that required by the Employer's Engineering Specifications, that shall be utilised in the Contractor's Designs, to the Project Manager for Acceptance by the Employer's Engineers. The Contractor is prohibited from installing said Plant without the required prior authorization from the Project Manager.
- d. The Contractor shall furnish samples of any Plant that is proposed to be used in the Contractor's Designs, to the Project Manager for Acceptance by the Employer's Engineers. The Contractor is prohibited from designing with, and subsequently installing said Plant without the required prior authorization from the Project Manager.
- e. The *Contractor* shall give notice to the *Project Manager* of the required inspection not less than 2 weeks before the inspection is required.
- f. The *Employer* will not provide any materials or facilities for the use of the *Contractor*, to perform tests and inspections.

### **5.4 Pre-Commissioning Tests and Commissioning**

- a. The *Contractor* is referred to Annexure N - High Level Commissioning Plan for details of the inspections tests and activities required for commissioning of Plant. Where the word or expression in the former document reads "Equipment" the meaning is "Plant" and vice versa. The contractor shall develop a detailed Commissioning plan, taking into cognisance the employer's High-Level commissioning plan, as part of the provisions of this contract and submit the commissioning plan to the Employer's Agent for acceptance.



- b. The *Contractor* shall arrange for Factory Acceptance Testing of selected Electrical and Mechanical Plant as required by the *Employer* at the Supplier's Premises before any Plant is despatched to site.
- c. The Factory Acceptance Testing shall be witnessed by the *Employer*, but in doing so; the *Employer* assume no responsibility or accountability for the proper functionality of the Plant in any way whatsoever.
- d. The *Contractor* shall arrange for Factory Acceptance testing for Electrical and Mechanical Plant at the factory of manufacture before the Plant leaves the factory.
- e. The *Contractor* shall arrange Site Acceptance Testing for the selected Plant when it arrives on Site.
- f. The Site Acceptance Testing shall be witnessed by the *Employer*, but in doing so; the *Employer* assumes no responsibility or accountability for the proper functionality of the Plant in any way whatsoever.
- g. The cost of the FATs and SATs, including travel, accommodation and daily stipend for the *Employer*, is part of this contract, and shall be included in the *Contractor's* Price. The anticipated number of persons to be catered for in this regard is 3 (Three) per FAT.
- h. The *Contractor* shall appoint an independent ECSA registered commissioning engineer to conduct and coordinate the commissioning activities. The Curriculum Vitae of the commissioning engineer shall be submitted to the *Employer* for acceptance before his/her appointment.
- i. The *Employer* reserves the right to reject the proposed commissioning engineer if he/her is deemed unsuitable to carry out the commissioning activities as required by the *Employer*.
- j. The installation shall be comprehensively tested and commissioned as individual and integrated systems as may be required by the configuration, after the *Works* are substantially complete.
- k. The *Contractor* shall provide adequate and competent personnel for testing and commissioning of every particular installation and for the full duration of the commissioning process.
- l. The commissioning shall include interaction between other systems and others where interdependence of installations is encountered.
- m. The commissioning process shall, after all testing has been completed be the final proving ground of the systems and during this procedure the installations shall be subjected to all possible inputs and actions which may be encountered under operational conditions.
- n. The *Contractor* shall prove the full operation, working and compliance of the installation in accordance with the specifications.
- o. A detailed programme of the planned commissioning procedures shall be submitted to the *Project Manager* at least 10 working days before commissioning commences.
- p. The commissioning programme shall include but is not limited to:



- A schedule of equipment to be commissioned, the proposed tests to be conducted and the testing methods and the range of acceptable results,
  - Commissioning check sheets,
  - Commissioning programme dates and duration
- q. The *Contractor* shall supply all relevant test equipment, monitoring devices, network analysers, protocol testers/analysers etc. required to test and commission the complete *Works*.
- r. An accurate record of all commissioning and testing is to be taken and included in the handover documentation as a permanent record.
- s. The *Contractor* shall perform all tests as required by any Sections or Clauses of the *Works* Information and all tests required by the *Employers* Specifications annexed thereto, and all tests required by any applicable SANS Standard, or other Standard, and/or as directed by the *Project Manager*.
- t. Testing and commissioning is considered part of the *Works* and is to be done before completion.

## 5.5 Take over procedures

The *Contractor* provides the following assistance to the *Employer*:

- a. The *Contractor* ensures that the documentation required as per this *Works* Information is presented to the *Project Manager* before Completion.
- b. The *Contractor* ensures that the *Project Manager* has a full and accurate dossier of As-built documents that represent the buildings, Plant, Switchgear, other systems that reflect the status of the completed *Works* for Mechanical, Electrical, Control and Instrumentation, General Layouts and Detail Drawings, (and including Plant within the *Works*) to present to the *Employer*.
- c. The *Contractor* must submit the following documents for the HVAC and Fire Protection systems as part of the Handover file:
- i. Final As-built drawings-signed off by ECSA professional designer
  - ii. Design Criteria
  - iii. Engineering design report
  - iv. Design Criteria
  - v. Operational manuals
  - vi. Maintenance manuals
  - vii. Training register of staff trained on the systems.
  - viii. COC-Certificates of Compliance

### **5.5.1 Access given by the Employer for correction of Defects**

The *Contractor* complies with the following constraints and procedures of the *Employer* where the *Project Manager* arranges access for the *Contractor* after Completion:

- a. Access into areas already handed over by the *Contractor* for correction of any defect shall be subject to the approval of Port's Operations, and these times shall be communicated to the *Contractor* by the *Project Manager*.
- b. The areas required by the *Contractor* will need to be temporarily barricaded by the *Contractor* before the *Contractor* commences with any corrective work.

### **5.5.2 The Contractor complies with the following constraints and procedures of the Employer where the Project Manager arranges access for the Contractor after Completion:**

- a. Where the *Contractor* has to return to Site after Completion to rectify notified Defects, the *Employer* may either impose the same Site access / egress restrictions as communicated elsewhere in the *Employer's Works* Information at the starting date / access date stated under Contract Data - Part One, or as the *Works* are now in use or the *Employer's* occupation of the Site may be incrementally or substantially changed post Completion, there may be further access / egress restrictions as required by the *Employer* and/The Port of EL.

### **5.6 Operational maintenance after Completion**

The *Contractor* performs the following operational maintenance in relation to the *Works* after Completion:

- a. The *Contractor* shall provide technical support and operational maintenance (by means of an OEM service and maintenance contract) to the Port for the Substation Switchgear for a period of 24 months after completion.
- b. After the expiry of the 24-month period, the OEM shall be required to offer a renewal of these contracts to TPT, at the same contract Price for the period, plus reasonable escalation, however, TPT reserves the right to decline the offer.
- c. The *Contractor* shall provide maintenance contracts for Plant as contained and required anywhere else in this Works Information.
- d. The *Contractor* shall include a maintenance contract for 24 months for the maintenance of complete HVAC system.
- e. The *Contractor* shall include a maintenance contract for 24 months for the maintenance of complete fire detection and suppression system.



## 5.7 Performance tests after Completion

The *Contractor* performs the following performance tests after Completion of the *Works*:

- a. The *Contractor* is required to demonstrate the functionality and performance of the Protection Relay settings for the Port of EL Substation installation, in its ability to function as a standalone system for the Substation, to the satisfaction of the Employer's Engineers.
- b. The *Contractor* is required to demonstrate the functionality and performance of the proposed Substation Protection Relay settings and the grading thereof, as a part of the overall integrated Protection Relay settings and the grading thereof, that service all the substations/works linked to the construction and operations of the proposed Substation.
- c. The *Contractor* shall perform all relevant testing and demonstrate the full functionality of the complete fire protection systems in both substation to the full satisfaction of the *Employer's Engineer*.
- d. The *Contractor* shall perform all relevant testing and demonstrate the full functionality of the complete HVAC systems in both substations to the full satisfaction of the *Employer's Engineer*.

## 5.8 Training and technology transfer

The *Contractor* facilitates the following requirements for training *Workshops* after Completion for the *Works* in use:

- a) The *Contractor* shall provide training for the Employer's selected staff in the maintenance and operations of all specialised Plant and Systems and Software, HVAC systems and FIRE systems, Switchgear and Protection Relays. Training cost is to be allowed for in the Contractor's Price.
- b) The *Contractor* is to train the *Employer's* staff on the power systems modelling and simulation software required as part of the scope of works.
- c) The Training shall be comprehensive with printed training manuals and electronic copies of such manuals made available to each delegate.
- d) The *Employer* envisages that the number of staff required to be trained will be 10, the exact number to be confirmed by the *Project Manager* during the provision of the *Works*.

## 6 Plant and Materials Standards and Workmanship

### 6.1 Plant and Materials

- a. The *Contractor* provides Plant and Materials for inclusion in the *Works* in accordance with the Standard Specifications and/or Project Specifications, unless otherwise stated elsewhere in the *Works* Information provided by the *Employer*. All Plant and Materials are new, unless the use of

old or refurbished goods and/or Materials are expressly permitted as stated by the *Project Manager*.

- b. The *Contractor* replaces any Plant and Materials subject to breakages (whether in the Working Areas or not) or any Plant and Materials not conforming to standards or specifications stated and notifies the *Project Manager* and the *Supervisor* on each occasion where replacement is required.
- c. No Plant or Materials will be provided "free issue" by the *Employer*.
- d. The *Contractor* provides all Plant and Materials necessary for the *Works*.
- e. The *Contractor* supplies all certification including test certificates, user manuals, maintenance manuals and data books with respect to Plant and Materials procured for the *Works*.

## 7 Detailed Engineering Scope of Works

### 7.1 Legal Requirements Regarding Designs

In addition to the specifications, TPT substations upgrade shall comply with the following relevant South African Acts and Regulations, and they shall apply in the order of precedence as listed below:

#### 7.1.1 Reference Documents

#### 7.1.2 Legislations

Table 4: List of South African and International Codes used in the development of this document.

Item	Document Number	Description
[1]	OSH ACT 85 of 1993	South African National Occupational Health and Safety Act 85 of 1993

### 7.1.3 Standards

Table 5: List of all South African and International Standards used in the development of this document.

Item	Document Number	Description
[1]	SANS 10142-1&2	Code of Practice for the Wiring of Premises.
[2]	SANS 62305-1	Protection against lightning Part 1: General principles
[3]	SANS 62305-2	Protection against lightning Part 2: Risk management
[4]	SANS 62305-3	Protection against lightning Part 3: Physical damage to structures and life hazard
[5]	SANS 62305-4	Protection against lightning Part 4: Electrical and electronic systems within structures
[6]	SANS 10313	Protection against lightning - Physical damage to structures and life hazard
[7]	SANS 10199	The design and installation of earth electrodes
[8]	SANS 1063	Earth rods, couplers and connections
[9]	SANS 10198-8	The selection, handling and installation of electric power cables of rating not exceeding 33 kV Part 8: Cable laying and installation
[10]	SANS 1091	National Colour Codes
[11]	SANS 1973-1	Low Voltage switchgear assemblies > 10kA
[12]	SANS 1973-2	Low Voltage switchgear assemblies < 10kA
[13]	SANS 10292	Earthing of Low Voltage (LV) distribution systems
[14]	SANS 60529	Degrees of protection by enclosure (IP codes)
[15]	SANS 61689	Instrument Transformer
[16]	SANS 62268	Electricity Metering Equipment
[17]	SANS 725	IEEE Guide for Safety in AC Substation Grounding



## 7.1.4 Specifications

Table 6: List of all Transnet Specifications used in the development of this document

Item	Document Number	Description
[1]	TPD-001-EL&PSPEC	Specification for electrical installations to buildings other than dwellings houses
[2]	TPD-002-DBSPEC	Specification for low voltage distribution boards
[3]	TPD-003-CABLESPEC	Specification for the supply and installation of medium voltage and low voltage electrical cables
[4]	TPD-004-EARTHINGSPEC	Specification for earthing and the protection of buildings and structures against lightning.
[5]	TPD-007-MVSWITCHSPEC	Specification for indoor medium/ high voltage (1kv to 33 kV) alternating current switchgear and control gear
[6]	TPD-008-MINISUBSPEC	Specification for Mini substations

## 7.2 Service Conditions

The plant/equipment shall be designed and rated for continuous operation under the following conditions: -

Altitude	0 to 1800m above sea level
Ambient air temperature	Max 45 deg. C; Min. -5 deg. C
Humidity	as high as 96 %
Lightning conditions	Severe with 11 flashes/km <sup>2</sup> /annum
In addition, the atmosphere will be Salt laden and corrosive industrial chemical and dust laden nature. Frequent heavy rains driven by wind reaching speeds of 100 Km/h and above.	

## 7.3 Low Voltage Power System

All Low Voltage equipment and or plants to be provided as part of the engineering solution shall normally operate in the following conditions:

Nominal system voltage:	400V
Minimum - Maximum system voltage:	380V - 420V
Nominal frequency:	50 Hz $\pm$ 2 Hz
No. of phases:	3 Phase and Neutral
Short Circuit	31.5kA
Neutral Point	Solidly Earthed

#### **7.4 Medium Voltage Power System**

All Medium Voltage equipment and or plants to be provided as part of the engineering solution shall normally operate in the following conditions:

Nominal system voltage:	11kV
Minimum - Maximum system voltage:	10.45kV – 11.55kV
Nominal frequency:	50 Hz $\pm$ 2 Hz
No. of phases:	3 Phase
Neutral Point	Solidly Earthed
Short Circuit	25kA



## 7.5 Design *Works to be executed by the Contractor*

- a. The *Contractor* shall appoint a protection *specialist/consultant* to perform medium voltage protection study for the entire Medium Voltage network.
- b. The *Consultant* shall perform a modelling and simulation study of the entire network using the latest version of ETAP<sup>PS</sup> (latest version) and produce a load flow, short circuit and protection study report for acceptance by the *Employer*.
- c. The *Contractor* shall procure the latest version of the ETAP software tool as per annexure P – ETAP SPECIFICATION. The software tool shall be handed-over to the *Employer* complete with the as-built model of the power system upon completion of the project.
- d. The *Consultant* shall implement the protection settings of the entire network based on the simulated model and protection study report.
- e. The *Contractor* shall test the integrity of the existing earthing system at the substation. The *Contractor* shall submit all test results to the *Project Manager* for acceptance by the *Employers Engineer*.
- f. For the proposed new installation and in the case where the existing earthing and bonding system does not comply with the requirement of SANS 10313 and the *Employer's* specification, the *Contractor* shall perform full/parts of the design of the earthing system for substation. All designs performed by the *Contractor* shall be undertaken by an accredited specialist and the credentials/CV of the specialist shall be submitted to the *Employers Engineer* for acceptance.
- g. All detailed designs of the plant in accordance with the specifications incorporated in this contract.
- h. The *Contractor* shall be responsible for the full detail design of the of a HVAC positive pressurised ventilation system which must ensure that a positive pressure is maintained in substation 1 and substation 2 relative to the surrounding plant environment which will have the purpose of preventing ingress of fine dust particles from the plant area into the substation rooms. The *Contractor* shall also be responsible for the full detail design of a HVAC air conditioning system for each substation rooms which will have sufficient cooling capacity to service all heat loads which exists in the substations 1 and 2. All designs must be carried out in compliance with the relevant SANS codes and ASHRAE design codes. All HVAC designs must be signed off by and ECSA registered professional Pr.Eng or Pr.Tech Eng which has adequate experience in the specific discipline and applicable system design.
- i. The *Contractor* shall be responsible for the full detail design of a Gaseous fire detection and suppression system. The fire suppression system detection and discharging of the



gas shall cover both the substation rooms as well as the cable trenches. Fire detection shall be designed to detect fire in trenches as well. The fire protection systems must be based on a total flooding gaseous agent which has a low ODP (ozone depletion potential). The gaseous suppression agent/gas must be FK-5-1-12 or any of the other of the Inert gasses which are most suitable for the substation, and which will fit into the space allowed for it inside each of the substations. It is the responsibility of the Contractor to ensure that most suitable type of system is designed. All designs must be carried out in accordance with the relevant SANS codes and other applicable codes of design.

- j. All fire detection and suppression designs must be signed off by and ECSA registered professional Pr.Eng or Pr.Tech Eng which has adequate experience in the specific discipline and applicable system design.
- k. The *Contractor* shall be responsible for taking the necessary on-site measurements and drafting of the relevant drawings needed/required as input to the HVAC system and Fire detection and suppression system designs.
- l. The *Contractor* shall as part of the design process of the HVAC and Fire Protection Systems compile and submit the following documents to the *Employer* during the design process at the various stages of the design process:
  - i. Concept drawings
  - ii. Detail design drawings, plan layouts, sections, elevations and relevant detail drawings.
  - iii. Design Criteria document which specifies the design premise, site conditions, codes of design, type of systems which will be designed, design approach etc.
  - iv. Engineering design report which must report on all the systems designed regarding the design process followed, the codes of design followed, the design considerations, explain how the specific system were arrived at in the design process as the best possible solution including all design calculations.

## **7.6 Construction *Works to be executed by the Contractor***

### **7.6.1 MV Switchgear Installation**

The *Contractor* shall apply for a working permit two weeks before any commencement of the MV works and ensure minimal disruption to operations.



#### 7.6.1.1 Existing Switchgear (and the associated installation) Disconnection in the Substation.

- a. The *Contractor* shall disconnect, remove and dismantle the existing 11kV MV switchgear. The removed 11kV switchgear shall be transported by the *Contractor* to the Transnet Port Terminals Depot within a radius of 5km and handed over to the depot electrical supervisor.
- b. The *Contractor* shall disconnect and remove the existing battery charger with battery banks and associated accessories including loading, transportation within a 5km radius; offloading and safe disposal storage as instructed by the Transnet Port Terminals electrical supervisor.
- c. The *Contractor* shall disconnect and remove the existing power factor correction equipment and associated accessories including loading, transportation within a 5km radius; offloading and safe disposal storage as instructed by the Transnet Port Terminals electrical supervisor.

#### 7.6.1.2 Grain Elevator Substation NO:1 (Basement) MV Plant SoW

- a. The *Contractor* shall supply, install and commission two 11kV incomer panels complete with protection relays, anti condensation heaters, Current and voltage transformers as per specification TPD-007-MVSWITCHSPEC and drawing: Grain Elevator MV Single Line Diagram and Floor Plans. The panels shall be bottom cable entry to allow installation of incoming cables from the Trench. The panels cable termination compartments shall be designed suitable for EN 50181 and DIN 47637 plug type terminations.
- b. The *Contractor* shall supply, install and commission three 11kV transformer feeder panel complete with protection relays, anti condensation heaters and instrument transformers as per specification TPD-007-MVSWITCHSPEC, and drawing: Grain Elevator MV Single Line Diagram and Floor Plans. The panels shall be bottom cable entry to allow feeding cables to the Trench. The switchgear cable termination compartments shall be designed suitable for EN 50181 and DIN 47637 plug type terminations.
- c. The *Contractor* shall supply, install and commission one spare 11kV transformer feeder panel complete with protection relays, anti condensation heaters and instrument transformers as per specification TPD-007-MVSWITCHSPEC, and drawing: Grain Elevator MV Single Line Diagram and Floor Plans. The panels shall be bottom cable entry to allow feeding cables to the Trench.
- d. The *Contractor* shall supply, install and commission one 11kV bus-section panel equal to the incomer panel, complete with protection relays, anti condensation heaters and instrument transformers as per specification TPD-007-MVSWITCHSPEC, and drawing: Grain Elevator MV Single Line Diagram and Floor Plans.



- e. The *Contractor* shall supply, install and commission one 11kV bus-riser panels/bus-bar Earth and VT panels.
- f. The *Contractor* shall design, supply, install and commission a power quality technology for the installation. The power quality requirement shall be informed by the power systems simulation study that is part of the contractor's scope. As part of the power quality and compliance requirement, the *Contractor* shall refurbish three transformers and change the oil to equal or similar approved to Ester oil that is PCB free and an alternative for mineral oil.
- g. The *Contractor* shall design, supply, install and commission the battery bank (enclosed in a cabinet) and battery terminal unit for the 11kV switchgear complete with protection and wiring.
- h. The *Contractor* shall design, supply, install and commission a complete arc ducting system for the 11kV switchgear as per specification TPD-007-MVSWITCHSPEC. (Ducting to extract to exterior of substation with suitable weatherproof stainless-steel cowl).

#### 7.6.2 LV Switchgear Installation

- a. The *Contractor* shall apply for a working permit 7 working days before any commencement of the LV works and ensure minimal disruption to operations.
- b. The *Contractor* shall disconnect, remove, and dismantle the existing 400V LV switchgear. The removed 400V switchgear shall be transported by the *Contractor* to the Transnet Port Terminals Depot within a radius of 5km and handed over to the electrical supervisor.
- c. The *Contractor* shall design, supply, and install a Low Voltage Substation Distribution Board for the substation as per Specification no TPD-002-DBSPEC, TPD-001-EL&PSPEC, LV single line drawing and TPD-003-CABLESPEC.
- d. The *Contractor* shall design, supply, and install a control panel for the proposed MV switchgear complete with cabling works as per Specification no TPD-002-DBSPEC, TPD-001-EL&PSPEC, and TPD-003-CABLESPEC.

#### 7.6.3 Cable Installation

- a. The Contractor shall disconnect the existing MV feeder and Incomer cables from the existing MV switchgear. The incomer cables shall be cut and joined with new 150mm<sup>2</sup> XLPE SWA Cu 11kV 3 core cables using transition joints. The MV transformer feeder cables shall be replaced with new cables 95mm<sup>2</sup> XLPE SWA Cu 11kV cables using the existing cable route.



- b. The Contractor shall disconnect the existing LV feeder and incomer cables from the existing LV switchgear. The mentioned cables to be disconnected shall be replaced with new 630mm<sup>2</sup> XLPE SWA Cu 11kV 1 core cables with new termination kits.
- c. The existing cable terminations shall be handed over to the Transnet Port Terminals Depot electrical supervisor.
- d. The *Contractor* shall supply new MV plug type terminations designed to EN 50181 and DIN 47637. The Contractor shall install and terminate all existing MV cables with new termination kits as per SANS 101980-4, Transnet specification TPD-003-CABLESPEC and drawing no: Grain Elevator MV Single Line Diagram and Floor Plans-04/02. The contractor to note that the switchgear cable compartment shall be manufactured (with the female end) to suit the plug type termination.
- e. The Contractor shall supply new LV standard type terminations. The Contractor shall install and terminate all existing LV cables with new termination kits as per SANS 101980-4, and Transnet specification TPD-003-CABLESPEC.
- f. The *Contractor* shall select, supply, and install transition joints from paper oil impregnated MV three core cables to single core XLPE SWA cables. The termination to switchgear shall be from XLPE cables.
- g. The Contractor shall seal and make good all cable entries and exits of the substation to block water from entering the substation trenches.

#### 7.6.4 Transformers in the substation/s.

- a. The Contractor shall design supply and install a stainless-steel containment tray around the existing transformers to contain the oil leaks from the transformers as required by SANS 10142.
- b. The *Contractor* shall change the 3xtransformer oil to biodegradable Ester oil, test, install and commission the existing transformers. The works shall be undertaken onsite with minimal disruption to operations.

#### 7.6.5 Design, Supply, and Installation, Testing, Commissioning and Handover of new HVAC systems

- a. The Contractor shall design, supply, install, test, commission, and handover a complete positive pressurised HVAC system for all the rooms in substation 1 and 2. This shall also include the testing and commissioning of newly installed HVAC systems.
- b. The HVAC system shall be designed in such a way that it will be able to provide adequate cooling for all the heat loads present in each of the substations 1 and 2.
- c. The HVAC system shall be a positively pressurised air conditioning system, to prevent ingress of dust and other fine particulate matter from the adjacent plant areas. This



design shall be carried out in accordance with the relevant SANS and ASHRAE design codes for this application to ensure efficiency and compliance.

- d. The ventilation of the building must be in accordance with the requirements of the Occupational Health and Safety Act 85, 1993 and the relevant SANS codes or as amended.
- e. The HVAC system shall be designed to conform to the SANS 10400 O and all other applicable standards.
- f. All refrigerants used in HVAC systems must have an Ozone Depletion Potential (ODP) of zero and a very low Global Warming Potential.
- g. The HVAC system must be interlocked with the fire detection and suppression system to allow for successful suppression in the event of a fire.
- h. HVAC Distribution Efficiency:
  - All supply and return air branch ducts shall include the appropriate style of volume damper. Air terminal devices such as grilles, registers, and diffusers shall be balanced at duct branch dampers, not at terminal face.
  - All ductworks shall comply with SANS 1238 and all the codes referred to herein.
  - All medium- and high-pressure ductwork systems shall be pressure-tested in accordance with the relevant SANS code.
  - All ductworks shall be insulated. No interior duct liner shall be permitted.
  - All HVAC equipment shall be isolated from the ductwork system with flexible duct connectors to minimize the transmittance of vibration.
  - All mechanical system components shall be new.
- i. The *Contractor* shall be responsible for the dismantling, and removal of all existing HVAC plant, materials and components in the substations and safely disposing thereof at a suitable off-site facility.
- j. The *Contractor* shall also be responsible for making good all openings used by existing HVAC plant and components which will no longer be used in the newly designed HVAC system.
- k. The *Contractor* must provide a 24-month warranty on the complete HVAC system.

#### 7.6.6 Design, Supply, Installation, Testing, Commissioning and Handover of Fire Protection systems.

- a. The Contractor shall design, supply, install, test, commission, and handover a complete fire suppression and detection system in all the rooms of the substation 1 and substation 2. This system must include fire detection for the substation rooms including the fire detection and suppression in cable trenches in the substation rooms.



- b. The *Contractor* shall also be responsible for the design, supply, installation, testing, commissioning and handover of all fire extinguishers, fire and escape signage in accordance with the relevant SANS codes.
- c. A fire stopping solution shall be installed between rooms and within the trenches. This will slow down the spread of a fire for a calculated length of time and would also allow for the designed suppression system to extinguish the fire.
- d. The *Contractor* shall supply and install fire and explosion proof barriers between the transformers to prevent fire spread and equipment damage due to explosions.
- e. The *Contractor* shall perform room integrity testing on each of the rooms of the substation, to ensure that all openings are tightly sealed to provide efficient containment of the fire suppression gas during a fire event. This would require any holes in walls, ceilings, etc. to be sealed using the correct method for the application.
- f. Any roller shutter doors, windows, louvers, etc. may require sealing along the edges, or alternatively, the installation of fire curtains to prevent the release of gasses to the outside during a suppression event may be required.
- g. The fire detection and suppression system must be suitably interlocked with the HVAC system in each of the rooms to ensure that the fire suppression system effectiveness is not hampered by the HVAC system operation. The necessary automated louvers and all other mechanisms to ensure an efficient suppression system must be included as part of the system.
- h. The *Contractor* shall be responsible for the dismantling, and removal of all existing fire protection systems, materials and components and safely disposing thereof at a suitable off-site facility.
- i. All inter-leading doors shall be fire rated to prevent a fire spreading between building compartments. The current doors need to be checked and replaced if required.
- j. Fire control, safety and risk management shall be conducted in full compliance with the National Building Regulations, SANS 10400-T, as amended and with all other applicable codes, Legislation and Regulations. It will be required that a complete Fire systems report be submitted, along with all other information regarding Fire Compliance for all rooms in the substations.
- k. The control panel for the monitoring of the fire detection system will be fitted to a Security Control Room to facilitate 24-hour monitoring.
- l. All fire detection and suppression system plant, components and fixtures shall be new.
- m. The *Contractor* must provide a 24-month warranty on the complete Fire Protection system.



#### 7.6.7 Substation building refurbishments.

- a. The *Contractor* shall supply and install new fire rated doors for the substation building.
- b. The *Contractor* shall supply and install new signages in accordance with the OHS Act.
- c. The *Contractor* shall undertake minor building refurbishments which includes but will not be limited to making good the substation floor, roof, and walls. A provisional sum will be allowed to undertake this work and the extent of the work shall be assessed and agreed in execution.
- d. All works shall be in accordance with SANS 10400 and the OHS Act.

#### 7.6.8 Testing and Commissioning of the installation

- a. The *Contractor* shall conduct a Factory Acceptance Test (FAT) for all Plant's to be installed as part of the Works to be executed in this Contract prior to delivery to site. The FAT shall be conducted in the presence of the *Employer's Engineers*. The legal transfer of ownership from the Plant's supplier to the *Contractor* shall be held by the *Contractor* until the Plant is fully installed, tested commissioned on the *Employer's* designated site.
- b. The *Contractor* shall conduct a Site Acceptance Test (SAT) for all Plant's supplied, offloaded, and delivered to the designated *Employer's* site. The SAT shall be conducted in the presence of the *Employer's* Engineer. The legal transfer of ownership from the Plant's supplier to the *Contractor* shall be held by the *Contractor* until the Plant is fully installed, tested commissioned on the *Employer's* designated site.
- c. The *Contractor* shall test the MV installation and LV installation and hand over all relevant test certificates to the *Employer's* engineer for acceptance. The *Contractor* shall hand over both MV and LV certificate of compliance respectively as per the OHS Act 85 and SANS 10142-1 and SANS1042-2 for the installation.
- d. The *Contractor* shall test and commission the entire Earthing system as per Transnet Specification TPD-004-EARTHINGSPEC and SANS 10142-1 in the presence of the *Employer's* Engineer. The *Contractor* shall handover all test certificates to the *Employer's Project Manager* for acceptance by the *Employer's* Engineers.
- e. The *Contractor* shall test and commission the protection system.
- f. The *Contractor* shall test and commission all HVAC systems and Fire detection and suppression systems in accordance with the relevant SANS and other applicable codes of standards.
- g. All COC (certificates of compliance) and other relevant certifications must be issued for all HVAC and fire detection and suppression systems.



## 8 List of Drawings

### 8.1 Drawings issued by the *Employer*

This is the list of drawings issued by the *Employer* at or before the Contract Date and which apply to this contract.

Note: Some drawings may contain both Works Information and Site Information.

**Table 7: Drawings**

Drawing number	Revision	Title
	0A	Port Switching Layout
	0A TD	Grain Elevator 12 <sup>th</sup> Floor Substation No2 Single Line and Layout Drawing
	0A TD	Grain Elevator MV Single Line diagram and Floor plan

## SECTION 2

### 9 Management and start up

#### 9.1 Management meetings

- a. It is the *Employer's* specific intention that the Parties and their agents use the techniques of partnering to manage the contract by holding meetings designed to pro-actively and jointly manage the administration of the contract with the objective of minimising the adverse effects of risks and surprises for both parties.
- b. Depending on the size and complexities of the Works, it is probably beneficial for the *Employer* to hold a weekly risk register meeting. This could be used to discuss safety, environmental, compensation events, subcontracting, overall co-ordination and other matters of a general nature. Separate meetings for specialist activities such as programming, engineering and design management, may also be warranted.

Regular meetings of a general nature may be convened and chaired by the Project Manager as follows:

Table 8: Communication Plan

Title and purpose	Approximate time & interval	Location	Attendance by:
Kick-Off Meeting	Prior to Commencement of Construction	Port of EL	<i>Employer, Contractor (key persons) and Project Manager (appropriate delegates)</i>



Contract Progress Meeting	Fortnightly	Port of EL	<i>Employer, Contractor (key persons) and Project Manager (appropriate delegates)</i>
Risk Register and Compensation Events	Weekly	Port of EL	<i>Project Manager (and appropriate delegates), Supervisor (and appropriate delegates) and Contractor (appropriate key persons)</i>
Monthly SHE meeting	Monthly	Port of EL	<i>Employer, Project Manager (and appropriate delegates), Contractor (line management, site Supervisors, safety officer, environmental officer and safety reps)</i>
Safety Visible Felt Leadership Walkabout	Weekly	On Site	<i>Project Manager (and appropriate delegates) and Contractor (appropriate key persons)</i>
Safety Workshop	Bi-weekly	On Site	<i>Contractor's site Supervisors</i>
Safety Committee Meeting	Every second month	Port of EL	<i>Employer, Contractor (key persons) and Project Manager (appropriate delegates)</i>

- c. Meetings of a specialist nature may be convened as specified elsewhere in this Works Information or if not so specified by persons and at times and locations to suit the Parties, the nature and the progress of the Works. Records of these meetings are to be submitted to the *Project Manager* by the person convening the meeting within 5 working days of the meeting.
- d. All meetings are to be recorded using minutes or a register prepared and circulated by the person who convened the meeting. Such minutes or register are not to be used for the purpose of confirming actions or instructions under the contract as these are to be done separately by the person identified in the conditions of contract to carry out such actions or instructions.
- e. The *Contractor* attends management meetings at the *Project Manager's* request as set out in the table above. At these meetings the *Contractor* presents all relevant data including safety, health



and environmental issues, progress reports, quality plans, Sub-contractor management reports, as may be required.

## 9.2 Documentation Control

- a. In undertaking the *Works* all documentation requirements for the *Works* shall be dealt with in accordance with document DOC-STD-0001 – Rev03 (*Contractor* Documentation Submittal Requirements). The control, maintenance and handling of these documents and drawings, using a suitable document control system, remain the sole responsibility of the *Contractor*.
- b. The *Contractor* Documentation Submittal Requirements (CDSR) is as contemplated in DOC-STD-0001 – Rev 03, as contained in the Annexure B.
- c. The *Contractor* documentation "Starter kit", as contemplated in DOC-STD-0001 – Rev 03, will be issued at the kick-off meeting following award.
- d. All contract correspondence is issued through document control. All hardcopy communication will be delivered to the *Employer* via the Lead Document Controller at the project site office document control department.
- e. Each supplier of documentation and data to the Project is responsible for ensuring that all documentation and data submitted conforms to the Project Standards and data Quality requirements in terms of numbering, uniqueness, quality, accuracy, format, completeness and currency of information. Data not meeting the Project Standards and data Quality requirements will be cause for rejection and returned to the *Contractor* for corrective action and re-submission.
- f. Should any change be made to documentation or data, which has already been submitted to the Project, then new or revised documentation or data shall be issued to replace the out-dated information.
- g. It is the responsibility of all Project participants undertaking work on the Project to ensure they obtain and comply with the relevant requirements to suit their deliverables and Scope of Work.
- h. The *Contractor* is to ensure that the latest version of the required application software and a suitable 'IT' Infrastructure is in place to support the electronic transmission of documentation.
- i. Electronic files submitted to the Project shall be clear of known viruses and extraneous "macros". The supplier of documentation is required to have, at all times, the latest generation of virus protection software and up-to-date virus definitions.
- j. The *Contractor* shall be responsible for the supply of all Sub-Supplier/*Contractor*/Manufacturer, etc. documentation and data related to their package of work and shall ensure that these Sub-Suppliers have the capability to supply the necessary documentation and data in the required time-frame and quality as outlined in the specified standards prior to awarding sub-orders.



- k. The required number of copies shall as a minimum be three (3) (1x original + 2 x hard copies), with the corresponding PDF and 'Native' file formats upon final submission.
- l. The *Contractor* shall apply "wet signatures" to the original Documentation before scanning the signed original and prior to formal submission to the Project.
- m. Final issues of all documentation shall be supplied to the Project in "wet signature" format along with the associated corresponding electronic 'native files' and PDF renditions.
- n. The *Contractor* shall ensure adequate resources are available to manage and execute the Document Control function as per the requirements of the Project. (*The Contractor* shall ensure that a dedicated Document Controller is available for the Project)

### 9.3 Safety risk management

- a. The Contractor complies with the following HAS specifications and standards:
  - i. Annexure C: Health and Safety Project Specification TRN-IMS-GRP-GDL-014.3;
  - ii. Occupational Health and Safety Act (Act 85 of 1993) and Regulations;
  - iii. Transnet health and safety policies and procedures;
  - iv. National Road Traffic Act.
- b. The Contractor ensures that its Subcontractors comply with the above-mentioned requirements.
- c. The Employer will acknowledge the achievement of specific safety milestones set for the project with regards to incident statistics, incident recording, safety observation and conversations (SOC's) participation, safety initiatives, etc.
- d. The Contractor makes the HAS specification available to its employees and subcontractors in the language of this contract and other local languages as required.
- e. The Contractor conducts a risk assessment and method statement pack prior to carrying out any activity on the Site to the approval of the *Project Manager*.
- f. The lines of communication of the various personnel acting on behalf of the *Project Manager*, who communicates directly with the *Contractor*, and his key persons with respect to the HAS specification, are contained within Annexure C (Health and Safety Project Specification TRN-IMS-GRP-GDL-014.3. One such person is the Clients appointed PrCHSA who will be responsible for obtaining the project construction work permit.
- g. The roles and responsibilities of the various personnel acting on behalf of the *Project Manager* with respect to the HAS Project specification and health and safety issues as per Annexure C (Health and Safety Specification TRN-IMS-GRP-GDL-014.3)



- h. The *Contractor* shall appoint a full time CHSO per shift, registered with SACPCMP for the duration of the works, the number of which depending on the scope, complexity, and high-risk activities involved, as required by the Construction regulations of 2014, regulation 8(5). The Health and Safety Officer(s) must be on site when work commences at the start of the day and must remain on site until all activities for that day (including the activities of sub-Contractors) have been completed.
- i. The CM is responsible, within the context of the HAS project Specification, for health and safety on the Site and reports to the *Project Manager*. The CM specific tasks are detailed in:
  - i. Annexure C (Health and Safety project Specification TRN-IMS-GRP-GDL-014.3).
- j. All items of plant, Equipment and vehicles travelling within the Site shall be equipped with fully operational amber rotating flashing lights. All vehicles shall be roadworthy and shall at all times adhere to all traffic signage and speed limits.
- k. All employees of the *Contractors* will undergo entry medicals at the *Contractor's* cost before the commencement of the project and thereafter on an annual basis inclusive of exit medicals. Medicals to include drug testing.
- l. Trainings as stipulated in the HS project specification will be conducted by relevant *Contractors* employees at the *Contractor's* cost before the commencement of the project
- m. All will comply with PPE requirements as mentioned in this document as well as HS project specification taking note that only long sleeve pants and shirts are allowed to be worn on site.
- n. Transportation of employees will not be allowed at the back of bakkies.
- o. All permit costs required for any activities relating to the project shall be for the *Contractors* account.
- p. The *Contractor* shall further comply with all applicable legislative requirements and standards with respect to his own activities and others on the Site. A health and safety file to be submitted by the *Contractor* 14 working days post award of tender for approval by the *Employer* or *Employers Representative* before site access can be granted. In addition, 14 working days should be allowed for health and safety file to be approved by the *Employer's* HS Staff as well as TPT SHEQ Department. The *Contractor* must allow for this in their scheduling.

## **9.4 Environmental constraints and management**

### **9.4.1 General**

- a. All work is to be conducted in accordance with the principles of the National Environmental Management Act, 1998 (Act no 107 of 1998) as well as all other applicable legislation, regulations,



the accepted environmental good practice inclusive of *Contractor* Environment and Sustainability Specification Guideline Annexure D (TRN-IMS-GRP-GDL 014.4).

- b. The *Contractor* Environment and Sustainability Specification Guideline provides an integrated approach to environmental management. This approach is designed to guide the appropriate allocation of human resources, assign responsibilities, develop procedures and ensure project compliance with regulatory and best practice requirements. The *Contractor* Environment and Sustainability Specification Guideline requirements shall be applicable to the main *Contractor* and all its service providers.
- c. The *Contractor* must sign the declaration of understanding as a commitment to abide with the *Contractor* Environment and Sustainability Specification Guideline. Sufficient environmental budget must be allocated to meet all the project environmental requirements for the duration of the contract.
- d. The *Contractor* shall perform the Works and all construction activities within the Site and Working Areas having due regard for the environment and environmental management practices as more particularly described within the Contractor Environment and Sustainability Specification Guideline.
- e. The *Contractor* must appoint a suitably qualified Environmental Officer with a relevant environmental qualification and environmental management experience.

## 9.5 Environmental Obligation

- a. The overarching obligations of the *Contractor* in terms of the Contractor Environment and Sustainability Specification Guideline before construction activities commence on the Site and/or Working Areas is to provide environmental method statements for all construction operations at the Site and/or Working Area and where requested by the Construction Manager. The *Contractor* shall comply with the following:
  - i. The *Contractor* shall identify the kinds of environmental impacts that will occur as a result of their activities and accordingly prepare separate method statements describing how each of these impacts will be prevented or managed so that the standards set out in the *Contractor* Environment and Sustainability Specification Guideline are achieved.
- b. The *Contractor* shall take note of the environmental sensitivity of the Project area and surrounding areas and shall erect and maintain a highly visible temporary fence/barrier along the boundaries of the Site and around any no-go areas that may be pointed out. Site demarcation must be done and be in place prior to commencement of any construction related activity, to the satisfaction of the Construction Manager and Project Environmental Manager.



- c. The *Contractor* must take note of various environmental monitoring requirements during construction, as specified by the *Contractor* Environment and Sustainability Specification Guideline, and must make adequate allowance for undertaking specified monitoring.
- d. The *Contractor* must appoint a waste removal Service Providers as per the TPT list of waste removal Service Providers (to be provided after contract award).
- e. The *Contractor* shall be responsible for rehabilitation/reinstatement and cleaning all areas to the satisfaction of the *Employer's* Environmental Officer or Construction Manager as detailed in the *Contractor* Environment and Sustainability Specification Guideline.

## 9.6 Quality assurance requirements

### 9.6.1 General Requirements

- a. The *Contractor* shall execute the works in accordance with the project specification General Quality Requirements for *Contractors* and Suppliers included in Annexure E (General Quality Requirements for *Contractors* and Suppliers) of the Works Information.
- b. The *Contractor's* Quality Management System shall conform to the International ISO 9001 Standard or an equivalent standard acceptable to the *Project Manager*.
- c. Prior to the commencement of the works on Site, the *Contractor* shall submit his quality assurance and control proposal(s) to the *Employer* for review and approval 14 working days post award of tender. Works on Site may only commence once these proposals have been approved by the *Employer*.
- d. This proposal shall detail the *Contractor's* quality management system as it applies to all aspects of supply or service provision, including design, procurement, manufacturing, construction, installation, erection, and commissioning.

The *Contractor* shall make allowance for the provision of suitably qualified quality control staff to manage and carry out inspection on all supplier/*subcontractor* activities in all disciplines included within the Works Information.

## 9.7 Quality Policy

- a. The Quality Policy is a concise document, approved by the *Contractor's* executive management that *defines* organisational goals and objectives with regard to quality, a commitment to meeting stated requirements and an undertaking to drive continuous improvement throughout the organisation's activities. It must be suitable for the organisation and provide a framework for establishing, communicating and monitoring performance against agreed quality objectives.



## 9.8 Project Quality Plan

- a. The *Contractor* shall submit a Project Quality Plan (PQP) within the period stated and, in any event, no later than 28 working days after the Contract start date, which shall also contain specific proposals and details with regard to quality control (QC) for the scope of the works.
- b. The PQP includes the *Contractor's* statement that outlines strategy, methodology, resources allocation, QA and quality control co-ordination activities to ensure that the works meet the standards stated in the Works Information.
- c. The PQP is generally in narrative form detailing the Project Specific QA and QC systems and controls required by the *Contractor* for the specific works.
- d. The requirements for a PQP are detailed in the project standard and shall include, but not be limited to, the following:
  - i. Include all quality activities relevant to the works, identifying all procedures, reviews, audits, controls and records used to control and verify compliance with the specified contractual requirements.
  - ii. Include a listing of all special processes (e.g. welding and non-destructive testing, cube testing, etc.) envisaged for use, including confirmation of personnel certification as required;
  - iii. Include a list of all proposed method statements for Site-based work activities;
  - iv. Include a description of the *Contractor's* project organization, with key positions and responsibilities identified and individuals named.

The organization structure shall also indicate the resources committed to the management / coordination of QA / QC activities, both within the *Contractor's* organization and that of his *subcontractors* and suppliers;
  - v. Include a listing of all Quality Control Plans (QCP's), and associated Field Inspection Checklists (FIC's), as applicable;
  - vi. Identify in the PQP any supplier/*subcontractor* work. Supplier/*subcontractor* quality plans shall be approved by the *Contractor*, and a copy forwarded to the *Project Manager* for approval;
  - vii. Include the proposed Authorized Inspection Authority (where applicable - for pressurized equipment and systems);
  - viii. Include a Data Book Index, scheduling the proposed quality records that will form the permanent record of conformance to requirements.

## 9.9 Submissions and Records

- a. The *Contractor* submits his Quality Management System documents to the *Project Manager* as part of his programme under ECC3 Clause 31.2 to include details of:
  - i. PQP for the contract;
  - ii. Quality Policy;
  - iii. Index of procedures to be used;
  - iv. A schedule of internal and external audits during the contract.
- b. The *Contractor* develops and maintains a comprehensive register of documents that will be generated throughout the works, including all quality related documents as part of its Quality Plan.
- c. The *Project Manager* indicates those documents required to be submitted for information, review or acceptance and the *Contractor* indicates such requirements within his register of documents. The register shall indicate the dates of issue of the documents and the dates upon which the *Project Manager* responded to documents submitted by the *Contractor*.
- d. The index of procedures shall contain a list of the *Contractor's* quality management system procedures to be applied during the course of the works, including any relevant instructions or 3rd tier quality system documentation. Where aspects of the works are to be subcontracted, the *Contractor* shall include procedures for the management of suppliers and *subcontractors*.
- e. A schedule of internal and external audits shall be included in the *Contractor's* PQP, detailing the location, frequency and extent of internal and external quality system audits to be carried out during the contract period. The schedule shall include all locations at which such audits are carried, i.e., the *Contractor's* offices and construction Sites, as well as the premises of suppliers and service providers.

## 9.10 Programme

### 9.10.1 General

The Contract programme, progress reports, subsequent updates, revisions and supplementary programmes as detailed in this section are an essential part of the project control system used by the *Employer* for managing the works and in monitoring the progress of the work under the Contract. The information and data provided by the *Contractor* pursuant to this procedure must therefore be reliable, accurate and timely in presentation.



### **9.10.2 Programme submission**

A copy of the *Contractor's* First Programme shall be submitted with the Tender Document Returnable Schedules that shall comply with the requirements as indicated in the Works Information. The *Contractor's* Detailed Programme shall be submitted in both hard and soft copy forms within two weeks of award using a computer software package approved by the *Project Manager*. The preferred software package is Microsoft Projects or Primavera/similar approved.

### **9.10.3 Contract Programme (Baseline)**

The *Contractor's* First Programme, agreeing with the tender submission, shall become the "Contract Programme" or "baseline" against which actual time performance will be compared. Once the baseline has been established, all subsequent programmes will have baseline (target) bars shown against each activity. This programme will be used as the basis on which all variations, extensions of time and changes to methods of delivery/execution shall be assessed.

Identified deviations from the baseline shall be addressed by the Contractor by either demonstrating that the deviation does not constitute a problem to the overall Contractor's Programme or providing a course of action to remedy the deviation.

### **9.10.4 Programme Information:**

The Tenderer clearly indicates in the schedule all milestones, activities & information related to the following:

1. Float,
2. Time Risk Allowances,
3. Health and safety requirements,
4. Procedures set out in this contract,
5. Work by the Employer and Others,
6. Access to a part of the site if later than its access date,
7. Acceptances,
8. Plant & Materials and other things to be provided by the employer,
9. Information by Others,
10. starting date, access dates, Key Dates and Completion Date

11. planned Completion for each Key Date for each option and the complete works
12. Shows how each activity on the Activity Schedule relates to the operations on each programme.

#### **9.10.5 Meet the required timeframes:**

Ability to provide the services in terms of the *Employer's* requirements within the required timeframe as stated in the Works Information and Tender Data by indicating, in a logical sequence, the order, the timing, and the duration of the works that will take place in order to Provide the Works. The Programme must clearly support and demonstrate alignment to the approach paper/Method statement as contained under **T.2.2-05**.

#### **9.10.6 Resourcing & Equipment:**

The Tenderer indicates for each operation, how the Tenderer plans to do the work identifying the principal Equipment and other resources which he plans to use. Resources & equipment are loaded against activities with their associated rates to the programme for evaluation.

#### **9.10.7 Revision to contract Schedule**

The *Project Manager's* written approval of any revised contract programme shall be given prior to the revised contract programme becoming the new contract programme. Additional detail may be inserted into the Contract Programme at the request of either the *Contractor* or the *Project Manager*. In such cases, the overall start and finish dates of the detail activities shall not vary from the original summary activity(s) that were replaced. All revisions to the contract programme shall be prepared by, and at the cost of the *Contractor*.

#### **9.10.8 Supplementary Programmes**

The *Project Manager* may at any time, and at the cost and expense of the *Contractor*, direct the *Contractor* to produce supplementary programmes to highlight a particular aspect of the work under the Contract. The *Project Manager* shall not unreasonably request supplementary programmes.

#### **9.10.9 Cash Flow**

The *Contractor* shall submit to the *Project Manager* a detailed cash flow chart based on the contract programme showing the anticipated cash flow as represented by expected payment claim submissions, not only payments received.

### **9.10.10 Progress Reporting**

To demonstrate the actual progress of the work under the Contract the *Contractor* shall, on a biweekly basis, update and submit the contract programme and the progress to the *Project Manager*. The contract programme shall be in the form of a two week look ahead schedule, and shall show the following two separate bars for each activity so as to enable comparison of the actual progress to the contract programme:

The contract programme "baseline" activity bar The current schedule activity bar identifying the currently forecast start and finish dates of the activity, and the status (% completion of each activity).

### **9.10.11 Progress Monitoring and Review**

Monitoring and review of the progress of work under the Contract shall consist of an assessment of all activities currently in progress. The following shall be determined:

- percentage complete;
- forecast completion date;
- deviations from the baseline programme, and
- actions required to remedy any deviations.

### **9.10.12 Monthly Status Report**

The *Contractor* shall provide a written status report by the 20th of each month or such other reporting period as may be required by the *Project Manager* from time-to-time. The report shall summarise progress and problems encountered during that month in respect of all parts of the work under the Contract.

- As a minimum the report shall include:
- progress against the current approved contract programme;
- summary of progress achieved during the period;
- list of milestones achieved during the period;
- status of design, procurement, and off-site works;
- status of on-site works;
- deviations from the contract programme "baseline", and in particular, the forecast completion

- dates of activities which have or should have commenced;
- status of approvals;
- actual or anticipated problems with corresponding action plans to minimise the impact;
- summary of works planned for the following period, and
- cash flow status versus the original forecast.

The progress report shall form the basis of a monthly progress meeting between the Project Manager and the *Contractor*

### 9.11 Staffing

- a. The *Contractor* shall nominate a suitably experienced quality representative for all aspects of the works, including general Site activities, with a staff complement that is adequate to perform the requirements of the PQP.
- b. The *Contractor* shall submit the CV of his nominated quality representative for the *Project Manager's* review and approval.

### 9.12 *Contractor's* management, supervision, and key people

- a. The *Contractor* shall make an adequate, experienced, and stable project team available for the duration of the contract. The Contractor must exercise every effort to minimise the replacement of project team members to ensure optimum contract management continuity and efficiency.
- b. The *Contractor* employs full time, fully qualified and experienced key persons who have been delegated sufficient authority to manage the contract efficiently on-Site during completion of the Works including and not limited to:
  - **Project Manager x 1**  
The Project Manager should at least have a minimum qualification of a National Diploma in Engineering and a SACPMP registration/Pr. CPM/PMP with at least 5 years post registration experience in Electrical MV/LV and building construction projects. The Project Manager must have experience working in at least 3 separate projects, with at least 1 project in excess of R10m in electrical works (MV and LV switchgear, and power transformer installation) component value.
  - **Construction Manager X 1**  
The Contract Manager or Site Agent must at least have a minimum qualification of a National Diploma in Electrical Engineering with a PR registration with ECSA as a Pr Tech Eng, with at least 5 years' post registration experience in electrical MV/LV substation design and construction. The Contract Manager or Site Agent

must have experience working in at least one substation project with MV and LV switchgear scope in excess of R10 million. SACPMP will be awarded as an education.

- **Contractor's Mechanical Engineer X 1**

The Mechanical Engineer must at least have a minimum qualification of a National Diploma in Mechanical Engineering with a PR registration with ECSA as a Pr Tech Eng, with at least 5 years' post registration experience in HVAC and Fire Protection design and installation.

- **Protection Engineer/Specialist x 1**

The Protection Engineer must at least have a minimum qualification of a National Diploma in Electrical/Electronic Engineering with a PR registration with ECSA as a Pr Tech Eng, with at least 5 years' post registration experience in electrical MV/LV power systems modelling and simulation of load flow, fault level, and protection. The protection specialist must have done a protection grading study, application and commissioning, and load flow analysis for a power system network similar to the requirement of the scope of this project with experience in ETAP or a similar software.

- **Installation Electrician X 1**

The Installation Electrician must have a minimum N6 qualification, an Electrical trade, registration with the department of Labour and have at least 5 years' in MV/LV Switchgear installations. The Installation Electrician must have experience working in at least one substation project with MV and LV switchgear scope. Cable termination and joining experience demonstration is expected.

- **Foreman (Electrical MV/LV) x 1**

The Electrical Foreman must have a minimum of NTC 4 Trade Certificate in Electrical Engineering with at least 5 years post certification experience in Electrical MV and LV Projects. The Electrical Foreman must have experience and/or preferably accreditation of plugged type termination from the manufacturer. The Foreman must have experience and/or preferably accreditation for trifurcation and transition MV joints.



- **Planner x1**

Planner should have at least a minimum qualification of a Diploma in one of the built environment disciplines and 5 years of experience working in Electrical MV/LV Projects as planner.

- **Quality Officer X 1**

Quality officer should have at least a minimum qualification of a Diploma in one of the built environment disciplines and a Certified qualification in quality systems with relevant quality experience in construction. At least 5 years of experience in a quality systems environment and relevant experience in electrical and mechanical construction projects is required.

- **Environmental Officer X 1**

Environmental Officer must be registered with SACNASP and must have a bachelor's degree in environmental management/science with a minimum of 5 years work experience in electrical and mechanical construction projects. Proof of professional registration and qualifications must be attached and certified by a Commissioner of Oaths.

- **Health & Safety Officer X 1**

Health and Safety Officers: Registered as Health and Safety Officer with SACPCMP with more than 5 years of experience on MV/LV electrical and mechanical construction projects and have a SAMTRAC or NEBOSH or modern SHEQ risk management training course as a minimum qualification.

- **Quantity Surveyor X 1**

The Quantity Surveyor should have a qualification of a Diploma in Quantity surveying, experience in cost installation of substation plant. The Quantity Surveyor must also have experience in Conveyor construction and also exhibit Mechanical design and installation experience associated with the any infrastructure, equipment related to the Substation.



- **Document Controller X 1**

Document controller should have at least a Higher Certificate in Office Administration and at least 5 years of experience working as a document controller in a construction environment.

The *Contractor* employs personnel listed above but not limited to those mentioned to perform the functions of key persons under NEC3 ECC Clause 24.1. These appointments shall have the necessary experience and be suitably qualified.

The *Contractor* provides an Organogram of all his key people (both as required by the *Employer* and as independently to be stated by the *Contractor* and how such key people communicate with the Project Manager and the Supervisor and their delegates.

- a. The *Contractor* appoints an EO as a key person under ECC Clause 24.1. The EO ensures that the works, including all parts thereof, are undertaken subject to prior environmental method statement(s), approved by the *Project Manager*, and ensures that all the project's EA, permits and licences and CEMPR are implemented by the Contractor in a timely and proper manner.
- b. The EO provides the *Project Manager* with all environmental method statements for approval prior to commencing with the required works. The EO tasks are:
  - i. Daily, weekly, and monthly inspections of the Site and working areas. Monitor compliance with
  - ii. the project's EA, permits and licences and CEMPr
  - iii. Reporting of environmental incidents to the *Project Manager*;
  - iv. Attendance at all SHE meetings, toolbox talks and induction programmes;
  - v. Litter control and ensuring the *Contractor* clears litter from the Site;
  - vi. Ensuring that environmental signage and barriers are correctly placed;
  - vii. The EO submits daily, weekly and monthly checklists to the *Employer's* EO/ECO.
- c. The Contractor nominates a CIRP as a key person under ECC Clause 24.1. The CIRP is based on Site and ensures that all reports and IR requests are submitted accurately and in a timely manner to the Project Manager. The CIRP tasks are:
  - i. Dedicated to human resources, industrial relations and any other *Contractor* employee related functions;
  - ii. Resolve all human resources and industrial relations matters arising from the *Contractor's* employees;

- iii. Represent the *Contractor* at all industrial relations meetings.

### **9.13 Training Workshops**

- a. The *Contractor* facilitates the following requirements for training *Workshops*:
  - i. Pre-mobilization workshop, scheduled for one week prior to Site establishment. Workshop will be attended by the Site management team including Site agents, all *Contractor's Supervisors* and safety personnel. Additional training will include, but is not limited to, SOC training as well as DSTI training,
  - ii. Formal training as stipulated in the Health and Safety Project Specification 1124367-02-HS-SP-0001 to be attended by *Contractors* identified personnel before commencement of any works
- b. The Contractor provides the following documentation to the Employer:
  - i. Health and Safety file, including Health and Safety Management Plan but not limited to:
  - ii. Valid Company Letter of Good Standing
  - iii. Medical certificates of fitness
  - iv. Incident Management procedures;
  - v. Performance Reporting;
  - vi. Site Training Packages;
  - vii. Safe Work Method Statements;
  - viii. Safety Procedures;
  - ix. Risk Assessment Process and as well as risk assessments for all activities;
  - x. Insurance provided by the *Employer*;
  - xi. Insurance provided by the *Employer* is contained in the Contract Data – Part 1

### **9.14 Contract change management**

- a. For ease of communication standard templates shall be used for contract change management. The *Contractor* forwards all correspondence with respect to contract change management, i.e. Early Warnings and notifications of Compensation Events, on the standard templates provided.

### **9.15 Provision of bonds and guarantees**



- a. The form in which a bond or guarantee required by the conditions of contract is to be provided by the *Contractor* is given in Part 1 Agreements and Contract Data.
- b. The *Contractor* provides a bond or guarantee as required by the conditions of contract concurrently with the execution by the Parties of the form of agreement for the ECC contract.

#### **9.16 Records of Defined Cost, payments & assessments of compensation events kept by Contractor**

- a. The *Contractor* keeps the following records available for the *Project Manager* to inspect:
  - Records of design employees location of work or professional engineers engaged by the *Contractor*
  - Records of people and Equipment within the working areas
  - Records of Equipment used and people employed outside the Working Areas
  - Records of quotations, invoices and pay slips.

#### **10 Plant and Materials**

- a. The *Contractor* provides plant and materials for inclusion in the works in accordance with COLTO 1208 Item (e), unless stated otherwise in the Works Information provided by the *Employer*. All Plant and Materials are new, unless the use of old or refurbished goods and/or materials are expressly permitted as stated elsewhere in this Works Information, or as may be subsequently instructed by the *Project Manager*.
- b. The *Contractor* replaces any Plant and Materials subject to breakages (whether in the working areas or not) or any plant and materials not conforming to standards or specifications stated and notifies the *Project Manager* on each occasion where replacement is required.

#### **11 Subcontracting**

Where the *Contractor* employs a *subContractor* who constructs or installs part of the works or who supplies plant and materials for incorporation into the works which involves a *subContractor* operating on the Site, then the *Contractor* ensures that any such *subContractor* complies with the Contractor Environmental and Sustainability Specification Guidelines as well as Contractor Health and Safety Specification Guidelines as described in the Works Information, as appropriate. The subcontract documentation shall place back-to-back obligations on the *subContractor*, which reflect the *Contractor's* obligations under the Contractor Environmental and Sustainability Specification Guidelines, all within the *Contractor's* quality management system, as per the Works Information.

Where the *Contractor* employs a *subContractor* who constructs or installs part of the works, or who supplies plant and materials for incorporation into the works which involves a *subContractor*



operating on the Site and/or working areas, then the *Contractor* ensures that any such *subContractor* complies with the PIRPMP as appropriate and that the subcontract documentation places back-to-back obligations on the *subContractor* which reflect the *Contractor's* obligations under the PIRPMP, all within the *Contractor's* quality management system as per the Works Information.

## **12 Procurement**

### **12.1 Code of Conduct**

12.1.1 The Employer aims to achieve the best value for money when buying or selling goods and obtaining services. This however must be done in an open and fair manner that supports and drives a competitive economy. Underpinning our process are several acts and policies that any supplier dealing with Transnet must understand and support. These are:

- i. The Transnet Procurement Procedures Manual (PPM);
- ii. Section 217 of the Constitution - the five pillars of Public PSCM (Procurement and Supply Chain Management): fair, equitable, transparent, competitive and cost effective;
- iii. The Public Finance Management Act (PFMA);
- iv. Specific goals; and
- v. The Anti-Corruption Act.

12.1.2 This code of conduct has been included in this contract to formally apprise Transnet Suppliers of Transnet's expectations regarding behaviour and conduct of its Suppliers.

### **12.2 Prohibition of bribes, Kickbacks, Unlawful Payments, and Other Corrupt Practices**

12.2.1 The *Employer* is in the process of transforming itself into a self-sustaining State-Owned Enterprise, actively competing in the logistics industry. Its aim is to become a world class, profitable, logistics organisation. As such, its transformation is focused on adopting a performance culture and to adopt behaviours that will enable this transformation.

12.2.1.1 The Employer will not participate in corrupt practices and therefore expects its suppliers to act in a similar manner.

- a) The *Employer* and its employees will follow the laws of this country and keep accurate business records that reflect actual transactions with and payments to our suppliers.



- b) Employees must not accept or request money or anything of value, directly or indirectly, to:
  - i. Illegally influence their judgement or conduct or to ensure the desired outcome of a sourcing activity;
  - ii. Win or retain business or to influence any act or decision of any decision stakeholders involved in sourcing decisions; or
  - iii. Gain an improper advantage.
- c) There may be times when a supplier is confronted with fraudulent or corrupt behaviour of the *Employer's* employees. We expect our Suppliers to use our "Tip-offs Anonymous" Hot line to report these acts. (0800 003 056).

12.2.1.2 The Employer is firmly committed to the ideas of free and competitive enterprise.

- a) The *Contractor* is expected to comply with all applicable laws and regulations regarding fair competition and antitrust.
- b) The *Employer* does not engage with non-value adding agents or representatives solely for the purpose of increasing fronting.

12.2.1.3 The Employer's relationship with suppliers requires us to clearly define requirements, exchange information and share mutual benefits.

- a) Generally, *Contractors* have their own business standards and regulations. Although Transnet cannot control the actions of our suppliers, we will not tolerate any illegal activities. These include, but are not limited to:
  - i. Misrepresentation of their product (origin of manufacture, specifications, intellectual property rights, etc.);
  - ii. Collusion;
  - iii. Failure to disclose accurate information required during the sourcing activity (ownership, financial situation, B-BBEE, etc.);
  - iv. Corrupt activities listed above; and
  - v. Harassment, intimidation, or other aggressive actions towards Transnet employees.



b) The *Contractor* must be evaluated and approved before any materials, components, products or services are purchased from them. Rigorous due diligence is conducted and the supplier is expected to participate in an honest and straight forward manner.

The *Contractor* must record and report facts accurately, honestly and objectively. Financial records must be accurate in all material respects.

### **12.3 Conflicts of Interest**

12.3.1 A conflict of interest arises when personal interests or activities influence (or appear to influence) the ability to act in the best interests of the *Employer*. These include but are not limited to:

- i. Doing business with family members
- ii. Having a financial interest in another company in our industry

### **12.4 The Contractor's Invoices**

All invoices submitted by the Contractor shall be VAT invoices, which shall be accompanied by a daily activity sheet, covering the services together with, where relevant, a brief explanation of the time covered, and full breakdown of expenses to which receipts relate.

#### **The invoice states the following:**

- Invoice addressed to Transnet Limited.
- Transnet Limited's VAT No: 4720103177.
- Invoice number.
- The Contractor's VAT Number.
- Referencing of the Purchase Order

#### **Invoices are to be delivered to:**

Transnet Port Terminals – Finance Department

1 Hely Hutchinson Rd

Quigney

East London

5201



Email address: tptcreditors-ELMPT@transnet.net

Email address: Nowhi.Hloma@transnet.net

The invoice is presented as an original.

## 12.5 People

Minimum requirements of people employed on the Site include the following:

- i. Employee's medical certificate
- ii. Health and Safety induction training

## 12.6 Contractor Liability

12.6.1 The *Contractor* warrants that it will be liable to the *Employer* for any loss or damage caused by strikes, riots, lockouts or any labour disputes by and/or confined to the *Contractor's* employees, which loss will include any indirect or consequential damages.

12.6.2 The *Contractor* warrants that no negotiations or feedback meetings by the *Contractor's* employees shall take place on the *Employer's* premises, whether owned or rented by the *Employer*.

12.6.3 The *Contractor* shall give notice to the *Employer* of any industrial action by the *Contractor's* employees immediately upon becoming aware of any actual or contemplated action that is or may be carried out on the *Employers* premises, whether owned or rented, and shall notify the *Employer* of all matters associated with such action that may potentially affect the *Employer*.

12.6.4 The *Contractor* is responsible for educating its employees on relevant provisions of the Labour Relations Act which deal with industrial action processes and the risks of non-compliance.

12.6.5 The *Contractor* is required to develop a contingency strike handling plan, which plan the *Contractor* is obliged to update on a three-monthly basis. The *Contractor* must provide the *Employer* with this plan and all updates to the plan. The *Contractor* is responsible to communicate with its employees on Site details of the plan.

## 12.7 Industrial Action by Contractors Employees



12.7.1 In the event of any industrial action by the *Contractor's* employees, the *Contractor* is required to provide competent contingency resources permitted in law to carry out any of the duties that are, or could potentially be, interrupted by industrial action in delivering the service.

12.7.2 The *Contractor* warrants that it will compensate the *Employer* for any costs the *Employer* incurs in providing additional security to deal with any industrial action by the *Contractor's* employees.

12.7.3 In the event of any industrial action by the *Contractor's* employees, the *Contractor* is obliged to prepare and deliver to the *Employer*, within two (2) hours of the commencement of industrial action, an industrial action report. If the industrial action persists, the *Contractor* is required to deliver the report at 8h30 each day.

12.7.4 The industrial action report must provide at least the following information:

- i. Industrial incident report;
- ii. Attendance registers;
- iii. Productivity / progress to schedule reports;
- iv. Operational contingency plan;
- v. Site security report;
- vi. Industrial action intelligence gathered.

12.7.5 The final industrial action report is to be delivered 24 hours after finalization of the industrial action.

12.7.6 The management of the *Contractor* is required to hold a daily industrial action teleconference with personnel identified by the *Employer* to discuss the industrial action, settlement of the industrial action, security issues and the impact on delivery under the contract.

12.7.7 The resolution of any disputes or industrial action by the *Contractor's* employees is the sole responsibility of the *Contractor*.

12.7.8 Access to the *Employer's* premises by the *Contractor* and its employees is only provided for purposes of the *Contractor* delivering its services to the *Employer*.

Should the *Contractor* and its employees not, for any reason, be capable of delivering its services, the *Employer* is entitled to restrict or deny access onto its premises and, unless otherwise authorized, such person will be deemed to be trespassing.



12.7.9 The *Contractor* performs the works having due regard to the PIRPMP, statutory requirements and industry agreements.

12.7.10 The *Contractor* complies with the requirements of the IRCC involving the engineering construction *Contractors* engaged (including all future *Contractors*) by the *Employer*.

12.7.11 The roles and responsibilities of the various personnel acting on behalf of the *Project Manager* with respect to IR issues are stated in the following paragraphs.

12.7.12 The PIRM is responsible for ensuring that the *Contractor* complies with the PIRPMP. 12.7.13 The PIRM acts on behalf of the *Project Manager*.

12.7.14 The PIRM specific tasks are:

- i. To liaise with the *Contractor* prior to the commencement of construction activities, as per the *Contractor's* programme accepted by the *Project Manager*, with respect to IR issues;
- ii. Responsible, inter alia, for day-to-day IR on the Site through the implementation of the PIRPMP;
- iii. The PIRM reports directly to the *Project Manager*.

## 13 SPECIFIC GOALS

### 13.1 General Conditions

13.1.1 The value of this bid is estimated to not exceed R50 000 000 (all applicable taxes included) and therefore the **80/20** preference point system shall be applicable. Despite the stipulated preference point system, Transnet shall use the lowest acceptable bid to determine the applicable preference point system in a situation where all received acceptable bids are received outside the stated preference point system.

13.1.2 Preference points for this bid shall be awarded for:

- (a) Price;
- (b) B-BBEE Status Level of Contribution.
- (c) Any other specific goal determined in Transnet preferential procurement policy.

13.1.3 The maximum points for this bid are allocated as follows:



**Table 9: Preference Points**

	<b>POINTS</b>
<b>PRICE</b>	<b>80</b>
<b>SPECIFIC GOALS</b>	<b>20</b>
<b>Total points for Price and Specific Goals must not exceed</b>	<b>100</b>

13.1.4 Failure on the part of a bidder to submit proof of specific goals together with the bid will be interpreted to mean that preference points for B-BBEE status level of contribution are not claimed.

13.1.5 The purchaser reserves the right to require of a bidder, either before a bid is adjudicated or at any time subsequently, to substantiate any claim in regard to preferences, in any manner required by the purchaser.

## 14 Definitions

- (a) **"all applicable taxes"** includes value-added tax, pay as you earn, income tax, unemployment insurance fund contributions and skills development levies;
- (b) **"B-BBEE"** means broad-based black economic empowerment as defined in section 1 of the BroadBased Black Economic Empowerment Act;
- (c) **"B-BBEE status level of contributor"** means the B-BBEE status received by a measured entity based on its overall performance using the relevant scorecard contained in the Codes of Good Practice on Black Economic Empowerment, issued in terms of section 9(1) of the Broad-Based Black Economic Empowerment Act;
- (d) **"bid"** means a written offer in a prescribed or stipulated form in response to an invitation by an organ of state for the supply/provision of services, works or goods, through price quotations, advertised competitive bidding processes or proposals;
- (e) **"Broad-Based Black Economic Empowerment Act"** means the Broad-Based Black Economic Empowerment Act, 2003 (Act No. 53 of 2003);
- (f) **"EME"** means an Exempted Micro Enterprise as defines by Codes of Good Practice under section 9 (1) of the Broad-Based Black Economic Empowerment Act, 2003 (Act No. 53 of 2003);
- (g) **"functionality"** means the ability of a bidder to provide goods or services in accordance with specification as set out in the bid documents;



- (h) **"Price"** includes all applicable taxes less all unconditional discounts.
- (i) **"Proof of B-BBEE Status Level of Contributor"** means:
  - 1) B-BBEE status level certificate issued by an unauthorised body or person;
  - 2) A sworn affidavit as prescribed by the B-BBEE Codes of Good Practice;
  - 3) Any other requirement prescribed in terms of the B-BBEE Act.
- (j) **"QSE"** means a Qualifying Small Enterprise in terms of a Codes of Good Practice under section 9 (1) of the Broad-Based Black Economic Empowerment Act, 2003 ( Act No. 53 of 2003);
- (k) **"rand value"** means the total estimated value of a contract in South African currency, calculated at the time of bid invitations, and includes all applicable taxes and excise duties.
- (l) **"Specific goals"** means targeted advancement areas or categories of persons or groups either previously disadvantaged or falling within the scope of the Reconstruction and Development Programme identified by Transnet to be given preference in allocation of procurement contracts in line with section 2(1) of the PPPFA.



## 15 Annexures

### List of Annexures:

- Annexure A : List of Drawings (Section 8)
- Annexure B : Contractor Documentation Submittal Requirements: DOC-STD-0001
- Annexure C : Health and Safety Specification: TRN-IMS-GRP-GDL-014.3
- Annexure D : Contractor Environment and Sustainability Specification Guideline: TRN-IMS-GRP-GDL 014.4
- Annexure E : General Quality Requirements for Contractors and Suppliers
  
- Annexure G : TPD-001-EL&PSPEC - Technical Specification for the Supply and Installation of Electrical Lighting and Power in Buildings other than Dwelling Houses
- Annexure H : TPD-002-DBSPEC - Technical Specification for the Design and Manufacturing of Low Voltage Distribution Boards
- Annexure I : TPD-003-CABLESPEC - Technical Specification for the Installation of Medium and Low Voltage Cables
- Annexure J : TPD-004-EARTHINGSPEC - Technical Specification for the Design Supply and Installation of Lightning Protection and Earthing for Buildings and Structures
- Annexure K : TPD-007-MVSWITCHSPEC - Technical specification for indoor medium/high voltage (1kV to 33kV) alternating current switchgear and control gear
- Annexure L : TPD-011-UPSSPEC - Specification for the design, supply, delivery and installation of the back up three phase uninterruptible power supply system
- Annexure M : Substation Assessment Report (Substation Conditional Assessment Report)
- Annexure N : High Level Commissioning Management Plan
- Annexure O : Baseline Security Risk Assessment
- Annexure P : ETAP SPECIFICATION

**Also refer to Addendum 02 for Additional Information and Revised Drawings**

Also refer to Addendum 03 for changes to C2.2 Bill of Quantities



TRANSNET PORT TERMINALS

TENDER NUMBER: iCLM EL 725/TPT

DESCRIPTION OF THE WORKS: THE REFURBISHMENT OF THE GRAIN ELEVATOR SUBSTATIONS AT THE EAST LONDON MULTI PURPOSE TERMINAL FOR TRANSNET SOC LTD (REG NO. 1990/000900/30) OPERATING AS TRANSNET PORT TERMINALS (HEREINAFTER REFERRED AS "TPT") FOR THE DURATION OF 12 MONTHS

## PART 4: SITE INFORMATION

Core clause 11.2(16) states

"Site Information is information which

- describes the Site and its surroundings and
- is in the documents which the Contract Data states it is in."

In Contract Data, reference has been made to this Part 4 of the contract for the location of Site Information

### 1. Description of the Site and its surroundings

#### 1.1. General description – East London Grain Elevator

The site is within the Buffalo City Metropolitan Municipality region in East London, situated in the Eastern Cape province. The Grain Elevator Terminal imports and exports agricultural products such as wheat, maize, soya beans.

**Figure 1: Locality Map**





TRANSNET PORT TERMINALS

TENDER NUMBER: iCLM EL 725/TPT

DESCRIPTION OF THE WORKS: THE REFURBISHMENT OF THE GRAIN ELEVATOR SUBSTATIONS AT THE EAST LONDON MULTI PURPOSE TERMINAL FOR TRANSNET SOC LTD (REG NO. 1990/000900/30) OPERATING AS TRANSNET PORT TERMINALS (HEREINAFTER REFERRED AS "TPT") FOR THE DURATION OF 12 MONTHS

Access is available through the main TNPA and TPT Security check points. At all times the Contractor will familiarise and adhere to ALL Employers (TPT) rules and regulations regarding security / access control. The Contractor shall however be responsible for his / her own security and the Employer (TPT) will not be held liable / responsible for any stolen / lost property, tools, and equipment by the Contractor.

### 1.2. Existing buildings, structures, and plant & machinery on the Site

Grain Elevator is surrounded by workshops and moving machinery for operations. It might be dusty due to the cargo that is stored in the terminal. The vicinity of work area and site offices has a traffic flow of the cargo handling equipment, trucks as well as the employees'. During the construction/ installation, the contractor must always maintain a safe access to port users.

The work will be performed inside grain facility where substations are situated.

### 1.3. Contractor Establishment

Upon receipt of the site access certificate, the contractor will be required to establish site offices and laydown areas. The facilities established on site will remain for the duration of the works, and connection points will be available for the contractor, however, the contractor will be required to pay for services utilized during the duration of the contract. The proposed contractor site establishment and laydown area is shown below.

**Figure 2: Site Establishment**



They must adhere to the basic screening (Alcohol and drug) requirements at all entry and exit points of the Port. If the contractor or its employees tested positive during the screening, employee will not be permitted inside the premises.

#### **1.4. Operations on the site**

The works will be performed in an operational environment; the road will remain operational with on-going traffic for the entire duration of the contract. The contractor is to take cognisance of the Transnet employees and its stakeholders in and around the road.

#### **1.5. Subsoil information**

Not applicable

#### **1.6. Hidden services**

Working inside Grain Elevator facility

#### **1.7. Other reports and publicly available information**

This report is to be read in conjunction with the C3 Works Information Report provided. It is envisaged that the contraction site will be available to the contractor through the duration of the works.

**To Whom It May Concern,**

**CERTIFICATE OF INSURANCE: TRANSNET (SOC) LIMITED – PRINCIPAL CONTROLLED INSURANCE**

In our capacity as Insurance Brokers to the Transnet Group of Companies, we hereby certify that the undermentioned insurances are currently in place:

INSURED: Transnet (SOC) Limited

PERIOD: 1 April 2024 to 31 March 2025 (Both days inclusive)

DIVISION: Transnet Freight Rail, Transnet Engineering, Transnet Properties, Transnet Pipelines, Transnet National Ports Authority and Transnet Port Terminals

THE INSURED'S VAT NO: 4720103177

THE INSURED'S COMPANY REGISTRATION NO: 1990/000900/30

POSTAL ADDRESS (Head Office) Carlton Centre, 150 Commissioner Street, Johannesburg, 2001

**CONTRACT WORKS INSURANCE**

Cover Provided : Contract Works - Physical loss or damage to the Property Insured which being materials, plant and other things for incorporation into the permanent works.

Insurer : Mirabilis (Santam Limited)

Policy Number : MZAR35023-CAR

The Contract Site : Any location within the Territorial Limits upon which The Insured Contract is to be executed or carried out as more fully defined in The Insured Contract documents together with so much of the surrounding area as may be required or designated for the performance of The Insured Contract.

Territorial Limits : The Republic of South Africa.

Additional Co-Insureds:

The Contractor: All Contractors undertaking work in connection with The Insured Contract including the Employer to the extent that the Employer undertakes work in connection with The Insured Contract;

Sub-Contractors: All Sub-Contractors employed by the Contractor and all other Sub-Contractors (whether nominated or otherwise) engaged in fulfilment of The Insured Contract; and to the extent required by any contract or agreement; transporters, suppliers, manufacturers, vendors, other persons, persons providing storage facilities, plant

owners and/or operators in respect of liability loss or damage arising out of The Insured Contract; project managers, architects, land surveyors, quantity surveyors, engineers and other advisors or consultants or sub-consultants appointed in the performance of the Insured Contract activities arising at the Contract Site provided always that any such person shall not be insured hereunder in respect of liability loss or damage arising out of such person's error or omission in the performance of the professional services for which he was appointed;

**Provincial & Government:** any Local Provincial or Government Department with which the Insured enters into any contract or agreement for the performance of The Insured Contract; all for their respective rights and interests.

**Insured Contracts :** All Contracts (including any undertaking awarded or commenced prior to Inception of the Period of Insurance) involving design, construction, Performance Testing and Commissioning in respect of the Works and shall Include capital expenditure, upgrade, modification, maintenance or overhaul, refurbishment, renovation, retrofitting or alterations and additions to existing facilities undertaken by the Insured or other Insured Parties acting on their behalf but **excluding**;

- a) contracts which at award stage have a value in excess of R 1,000,000,000;
- b) contracts with an estimated construction period exceeding 48 months but increasing to 60 months in respect of rail maintenance contracts and Transnet Freight and Rail contracts for logistical support for inline inspections and identification of defects over a 5 year period in respect of Transnet's pipeline assets (excluding Defects Liability/Maintenance period);
- c) contracts involving construction or erection of petrochemical manufacturing plant(s) but this exclusion shall not apply to pipelines and other associated works undertaken by or on behalf of the Insured;
- d) contracts in or on any aircraft;
- e) Off-shore contracts;
- f) Wet Risk Contracts which at award exceeds R500,000,000;
- g) Dam Contracts
- h) Tunnel contracts which at award exceeds R50,000,000;
- i) Tunnel contracts using tunnel boring machines;
- j) Underground Mining Contracts;
- k) Horizontal Directional Drilling Contracts which at award exceeds R50,000,000;
- l) Horizontal Directional Drilling Contracts where total drilling exceeds 1 km;
- m) Horizontal Directional Drilling Contracts for pipe diameters greater than 76 cm.

### Definitions

1. "Off-shore contracts" means all works and installations in the sea or on the seabed including dredging which are accessible only by ship boat barge or helicopter and do not constitute normal wet works like harbours moles bridges wharves or sewage or cooling water intake or outlet facilities. "OffShore Contracts" shall include oilrigs and oil platforms (but not including oil platforms when connected to the land on completion). The term shall not apply to pre-fabrication works on land associated with an Off-Shore Contract.

- 2 *"Wet Risk Contracts" shall mean any Contract and/or Works where more than thirty-five (35) percentile of its value is in a permanent body of water or is below the high water mark of any tidal body of water. The term shall include contracts for the construction of wharves, piers, marinas, causeways, breakwaters, jetties, dry docks and offshore pipelines when connected directly to on-shore facilities and canal developments. Wet Risks shall exclude Off- Shore Contracts;*
- 3 *"Dam Contracts", which term shall include weirs and hydroelectric projects involving the construction of dams or weirs;*
- 4 *"Horizontal Directional Drilling Contracts", means micro-tunnelling work for the construction of tunnels utilising surface based horizontal directional drilling equipment.*
- 5 *Tunnels" means Tunnels (Including declines) involving all of the following;*
  - (a) Works below ground level; and
  - (b) Tunnelling machinery below ground level; and
  - (c) A tunnelling crew operating the machinery below ground level;
  - (d) But shall not include Horizontal Directional Drilling Contracts
- 6 *"Horizontal Directional Drilling Contracts", means micro-tunnelling work for the construction of tunnels utilising surface based horizontal directional drilling equipment.*
- 7 *"Underground Mining Contracts", which shall mean any contract involving underground mining.*

Testing Period: 120 Days not consecutive.

Maintenance Period : 12 Months

Main Policy Extensions :

- Costs & Expenses - Limited to a maximum of R50,000,000.
- Expediting Measures – Limited to a maximum of R50,000,000.
- Professional Fees In Reinstatement Of Property Insured - Limited to a maximum of R50,000,000.
- Costs & Expenses For Removal Of Debris No Damage - Limited to a maximum of R50,000,000.
- Surrounding Property in care custody or control of the contractor – Limited to a maximum of R55,000,000.
- Fire Brigade & Public Authorities - Limited to a maximum of R10,000,000.
- Public Authority Reinstatement Costs - Limited to a maximum of R20,000,000
- Public Relationship Costs - Limited to a maximum of R1,000,000.
- Records - Limited to a maximum of R2,000,000.
- Removal to Gain Access - Limited to a maximum of R20,000,000

- Road Reserve and Servitude Extensions - Limited to a maximum of R10,000,000
- Search & Locate Costs - Limited to a maximum of R20,000,000.
- Borrowing Of Plant For Commissioning Purposes - Limited to a maximum of R10,000,000
- Escalation during Construction – 30%
- Marine Contribution Clause
- Claim Preparation Costs – Limited to a maximum of R10,000,000

Main Policy Exclusions :

- War
- Nuclear Energy Risks
- Terrorism
- Computer Loss General Exception
- DE4 (All types of Works) for defective material workmanship design plan or specification.
- LEG 3 (Mechanical or Electrical Engineering Works only) for defective material workmanship design plan or specification. Limited to maximum of 10% of the total estimated contract value in the aggregate.
- Loss or damage arising during air transit or any ocean voyage or whilst in storage thereafter.
- Occurring during any defects/maintenance period unless cause occurred prior to such defects/maintenance period
- Disappearance or by shortage revealed during routine inventory or periodic stocktaking.
- Consequential loss of whatsoever nature.
- Normal wear and tear, normal atmospheric conditions, rust, erosion, corrosion or oxidisation.
- Due to its own explosion breakdown or derangement occurring after the Testing Period which has operated under load conditions.
- Second hand property due to its own electrical or mechanical breakdown or explosion.
- Cyber and Data
- Beneficial Occupation – 12 months
- Risk Mitigation – Safety Measures with Respect to Precipitation, Flood and Inundation – 10 years return period

Deductibles:

In respect of loss or damage:

Major Perils shall mean damage caused by storm, rain, tempest, wind, flood, theft, malicious damage, subsidence, collapse, earthquake, testing or commissioning and the consequences of defective design, specification, materials or workmanship (DE4).

Minor Perils shall mean damage caused by a peril not defined as Major Perils defined above.

Contracts with a contract value :                      Major perils                      Minor perils



0 to R100,000,000	R25,000	R15,000
R100,000,001 to R250,000,000	R50,000	R15,000
R250,000,001 to R500,000,000	R100,000	R25,000
R500,000,001 to R1,000,000,000	R150,000	R25,000

Minimum wet risk deductible of R100,000 per occurrence to apply.

Electrical Cables, Wiring and Accessories 10% of claim minimum R100,000

LEG 3 Deductible (Only in respect of Mechanical and Electrical contracts);

Contracts with a contract value	Deductible
0 to R500,000,000	R1,000,000 per occurrence
R500,000,001 to R1,000,000,000	R1,500,000 per occurrence

## PUBLIC LIABILITY

Cover Provided :	Contract Works Public Liability – cover the Insured’s legal liability in respect of loss or damage or injury to third parties arising out of work performed in respect of the Insured Contracts.
Insurer :	Stalker Hutchinson (Santam Limited)
Policy Number:	6000/132335
Territorial Limits :	The Republic of South Africa.
Insured Contracts:	<p>All contracts (including any undertaking awarded or commenced prior to inception of the period of Insurance) involving design, construction, performance testing and commissioning in respect of the works and shall include capital expenditure, upgrade, modification, maintenance or overhaul, refurbishment, renovation, retrofitting or alterations and additions to existing facilities undertaken by the Insured or other Insured Parties acting on their behalf but <b>Excluding</b>:</p> <ol style="list-style-type: none"> <li>Contracts which at award stage have a value in excess of R 1,000,000,000.</li> <li>Contracts with an estimated construction period at award exceeding 48 months but 60 months in respect of contracts awarded prior to 1 April 2020 for rail maintenance contracts For Transnet Freight &amp; Rail and for Transnet Pipeline’s logistical support for inline inspections and identification of defects in respect of Transnet’s pipeline assets (all excluding Defects Liability/Maintenance period).</li> <li>Contracts with a Contractual Defects Liability Maintenance Period exceeding 24 months.</li> <li>Contracts involving construction or erection of petrochemical manufacturing plant(s) but this exclusion shall not apply to pipelines and other associated works undertaken by or on behalf of the Insured.</li> <li>Contracts in or on any aircraft.</li> <li>Off-shore contracts - “Off-shore contracts” means all works and installations in the sea or on the seabed and do not constitute normal Wet Risk Contracts like</li> </ol>

harbours, moles, bridges, wharves or sewage or cooling water intake or outlet facilities, piers, marinas, causeways, breakwaters, jetties, dry docks and offshore pipelines when connected directly to onshore facilities and canal developments. "Off-Shore contracts" shall include oilrigs and oil platforms.

Policy Limits:

Contractors Public Liability	R100,000,000 any one occurrence / unlimited during the Period of Insurance
Contractors Negligent Removal or weakening of Support	R100 000 000 any one occurrence and R100,000,000 per site in the aggregate during the Period of Insurance.
Statutory Legal Defence Costs	*R5 000 000 in the aggregate during the Period of Insurance.
Arrest / Assault / Defamation	*R5 000 000 in the aggregate during the Period of Insurance.
Prevention of Access	*R5 000 000 in the aggregate during the Period of Insurance.
Trespass / Nuisance	*R5 000 000 in the aggregate during the Period of Insurance.
Claims Preparation Costs	R5 000 000 any one occurrence

\*Where the limits are noted as in the aggregate during the policy period of insurance, that such aggregated limit is applicable to all Transnet Insured Contracts collectively and in total and does not apply to each contract separately.

Deductible(s) : R50,000 per occurrence but increased to R5,000,000 in respect of Spread of Fire and/or Hot Works and R250,000 in respect of Sudden and Accidental Pollution and/or Goods on the Hook and/or R150,000 in respect of Developers Removal of Support.

General Policy Exclusions :

The policy does not cover:-

- deliberate, conscious and intentional disregard to take reasonable precautions.
- fines, penalties, punitive and exemplary damages.
- Pollution unless caused by a sudden, unintended and unexpected occurrence.
- cost of removing, nullifying or cleaning up the effects of pollution unless caused by a sudden, unintended and unexpected occurrence.
- the hazardous nature of asbestos.
- War And Terrorism Risks.
- Nuclear Risks.

- Actual or alleged unlawful competition, unfair practices, abuse of monopoly power, cartel activities
- Compulsory Insurance
- Loss or damage and any consequence therefrom to any Data. •
- Sanctions Exclusion
- Grid Failure

## PROFESSIONAL INDEMNITY

Cover Provided :

Professional Indemnity

- a) In respect of damages which the Insured shall become legally liable to pay in consequence of neglect, error or omission by or on behalf of the Insured in the conduct or execution of their Professional Activities and Duties as defined.
- b) Prior To Handover/Rectification - against loss arising out of any defect in the works discovered prior to the issue of any practical completion or take-over certificate provided that any such defects are caused by a negligent breach of a Professional Activity or Duty by the Insured in consequence of neglect, error or omission by or on behalf of the Insured.

Insurer :

Stalker Hutchinson (Santam Limited)

Policy Number:

6000/132337

Jurisdiction :

Worldwide excluding North America

Insured Contracts:

All contracts (including any undertaking awarded or commenced prior to inception of the period of Insurance) involving design, construction, performance testing and commissioning in respect of the works and shall include capital expenditure, upgrade, modification, maintenance or overhaul, refurbishment, renovation, retrofitting or alterations and additions to existing facilities undertaken by the Insured or other Insured Parties acting on their behalf but **Excluding**:

- a) Contracts which at award stage have a value in excess of R 1,000,000,000.
- b) Contracts with an estimated construction period at award exceeding 48 months (excluding Defects Liability/Maintenance period).
- c) Contracts with a Contractual Defects Liability Maintenance Period exceeding 24 months.
- d) Contracts involving construction or erection of petrochemical manufacturing plant(s) but this exclusion shall not apply to pipelines and other associated works undertaken by or on behalf of the Insured.
- e) Contracts in or on any aircraft.
- f) Off-shore contracts - "Off-shore contracts" means all works and installations in the sea or on the seabed and do not constitute normal Wet Risk Contracts like harbours, moles, bridges, wharves or sewage or cooling water intake or outlet facilities, piers, marinas, causeways, breakwaters, jetties, dry docks and offshore pipelines when connected directly to onshore facilities and canal developments. "Off-Shore contracts" shall include oilrigs and oil platforms.



Limit Of Indemnity: Professional Indemnity - \*R100,000,000 in the aggregate during the policy period of insurance.

\*Where the limit is noted as in the aggregate during the policy period of insurance, that such aggregated limit is applicable to all Transnet Insured Contracts collectively and in total and does not apply to each contract separately.

Policy Extension  
Limits Of Indemnity:

Claims Preparation Costs - \*R7,500,000 in the aggregate during the policy period of insurance.  
 Loss of Documents - \*R2,000,000 in the aggregate during the policy period of insurance.  
 Statutory Defence Costs - \*R5,000,000 in the aggregate during the policy period of insurance.  
 Defamation - \*R5,000,000 in the aggregate during the policy period of insurance.  
 Infringement of Copyright - \*R5,000,000 in the aggregate during the policy period of insurance.

\*Where the limits are noted as in the aggregate during the policy period of insurance, that such aggregated limit is applicable to all Transnet Insured Contracts collectively and in total and does not apply to each contract separately.

Deductibles:

R5,000,000 each and every but R10,000 in respect of Claims Preparation Costs, Loss of Documents, Statutory Defence Costs, Defamation and Infringement Of Copyright.

Policy Special Conditions :

Condition precedent to liability that the Insured is fully qualified and registered with the relevant Industry Body/Association in terms of legislation as applicable.

Prior to hand over/rectification – the insured must give prior written notice to the Insurers of the intention to take remedial action to rectify such defect and obtain the Insurers' written agreement to such action being taken and the costs and expenses expected to be expended.

Policy Main Exclusions:

- Excludes all consequential loss other than cost of re-design, rectification and replacement as a consequence of the defect.
- Excludes Supervision.
- Excludes liability arising out of environmental impairment / pollution
- Excludes the cost of removing, nullifying or cleaning-up the effects of environmental impairment/ pollution.
- Excludes war, invasion, acts of foreign enemies, hostilities or warlike operations (whether war be declared or not), civil war, rebellion, revolution, insurrection, civil commotion assuming the proportions of or amounting to an uprising, military or usurped power, any act of terrorism and nuclear risks.
- Excludes fines, penalties, punitive and exemplary damages, multiplication of compensatory damages and/or any other noncompensating damages of any kind.



- Excludes liability from the hazardous nature of asbestos.
- Excludes medical malpractice.
- Excludes failure to meet contractual requirements relating to efficiency, output or durability.
- Excludes failure to meet completion dates
- Excludes the estimation of probable costs other than cost advice and cost planning services normally provided by a Quantity Surveyor or Project manager.
- Excludes incorrect authorisation of payment.
- Excludes breach of any statutory regulation.
- Excludes liability from the insolvency, liquidation or judicial management of the Insured.
- Excludes the certification of value of work executed by any contractor where the Insured has an equity interest in such contractor;
- Excludes liability due to unlawful competition, unfair practices, abuse of monopoly power, cartel activities or breach of a competitions ac
- Sanctions Exclusion
- Grid Failure

**This certificate of the insurance cover arranged is issued as a matter of information only and confers no rights upon the certificate holder. This certificate does not amend, extend or alter the coverage afforded by the policies issued by Insurers.**

Dennis Govender

Chief Broking Officer